

7SR224 Recloser Controller

Overcurrent Relay

Document Release History

This document is issue **2010/09**. The list of revisions up to and including this issue is:

2010/09	First issue
---------	-------------

Software Revision History

2010/09	2435H80011R4f-4b	IEC60870-5-101 protocol added

The copyright and other intellectual property rights in this document, and in any model or article produced from it (and including any registered or unregistered design rights) are the property of Siemens Protection Devices Limited. No part of this document shall be reproduced or modified or stored in another form, in any data retrieval system, without the permission of Siemens Protection Devices Limited, nor shall any model or article be reproduced from this document unless Siemens Protection Devices Limited consent.

While the information and guidance given in this document is believed to be correct, no liability shall be accepted for any loss or damage caused by any error or omission, whether such error or omission is the result of negligence or any other cause. Any and all such liability is disclaimed.

Contents

Document Release History	1
Software Revision History	1
1. Function Diagram	7
2. Menu Structure	8
2.1. Standard	8
2.2. Loss Of Voltage	9
2.3. Single/Triple	10
3. Relay Settings – Standard	11
3.1. System Config	11
3.2. CT/VT Config	12
3.3. Function Config	14
3.4. Current Prot'n	17
3.4.1. Phase Overcurrent	17
3.4.1.1. 51-1	17
3.4.1.2. 51-2	18
3.4.1.3. 51-3	18
3.4.1.4. 51-4	19
3.4.1.5. 50-1	20
3.4.1.6. 50-2	20
3.4.1.7. 50-3	21
3.4.1.8. 50-4	21
3.4.2. Voltage Cont O/C	21
3.4.3. Cold Load	22
3.4.4. Measured E/F	24
3.4.4.1. 51G-1	24
3.4.4.2. 51G-2	25
3.4.4.3. 51G-3	25
3.4.4.4. 51G-4	26
3.4.4.5. 50G-1	27
3.4.4.6. 50G-2	27
3.4.4.7. 50G-3	27
3.4.4.8. 50G-4	28
3.4.5. Sensitive E/F	29
3.4.5.1. 51SEF-1	29
3.4.5.2. 51SEF-2	29
3.4.5.3. 51SEF-3	30
3.4.5.4. 51SEF-4	31
3.4.5.5. 50SEF-1	31
3.4.5.6. 50SEF-2	32
3.4.5.7. 50SEF-3	32
3.4.5.8. 50SEF-4	32
3.4.6. Restricted E/F	33
3.4.7. NPS Overcurrent	33
3.4.7.1. 46IT	33
3.4.7.2. 46DT	33
3.4.8. Under Current	34
3.4.8.1. 37-1	34
3.4.8.2. 37-2	34
3.4.9. Thermal	34
3.5. Voltage Prot'n	34
3.5.1. Phase U/O voltage	34
3.5.1.1. 27/59-1	35
3.5.1.2. 27/59-2	35
3.5.1.3. 27/59-3	36
3.5.1.4. 27/59-4	36
3.5.2. Vx U/O voltage	37
3.5.3. NPS overvoltage	37
3.5.3.1. 47-1	37
3.5.3.2. 47-2	37
3.5.4. Neutral overvoltage	38
3.5.4.1. 59NIT	38
3.5.4.2. 59NDT	39
3.5.5. U/O Frequency	39

3.5.5.1.	81-1	39
3.5.5.2.	81-2	39
3.5.5.3.	81-3	40
3.5.5.4.	81-4	40
3.6.	Supervision	41
3.6.1.	CB Fail	41
3.6.2.	VT supervision	41
3.6.3.	CT supervision	42
3.6.4.	Broken Conductor	42
3.6.5.	Trip CCT supervision	42
3.6.6.	Inrush detector	43
3.6.7.	Battery Test	43
3.6.8.	Capacitor Test	44
3.6.9.	Power Quality	44
3.6.10.	27SAG	44
3.6.11.	59SWELL	44
3.7.	Control & Logic	45
3.7.1.	Autoreclose Prot'n	45
3.7.2.	Autoreclose Config	46
3.7.2.1.	P/F SHOTS	47
3.7.2.2.	E/F SHOTS	48
3.7.2.3.	SEF Shots	49
3.7.2.4.	Extern Shots	49
3.7.3.	(Re)closure Mode	50
3.7.4.	Synchronising Check	51
3.7.5.	Manual Close	53
3.7.6.	Circuit Breaker	53
3.7.7.	Quick Logic	54
3.8.	Input Config	64
3.8.1.	Input Matrix	64
3.8.2.	Function Key Matrix	86
3.8.3.	Binary Input Config	87
3.8.4.	Function Key Config	90
3.8.5.	General Alarms	91
3.9.	Output Config	92
3.9.1.	Output Matrix	92
3.9.2.	Binary Output Config	123
3.9.3.	LED Config	124
3.9.4.	Pickup Config	125
3.10.	Maintenance	125
3.10.1.	CB Counters	125
3.10.2.	I ² T CB Wear	126
3.10.3.	Output Matrix Test	127
3.11.	Data Storage	127
3.11.1.	Demand/Data Log	127
3.11.2.	Waveform Storage	127
3.11.3.	Fault Storage	128
3.11.4.	Event Storage	128
3.11.5.	Energy Storage	128
3.12.	Communications	129
4.	Relay Settings – Standard Plus LOV	131
4.1.	System Config	131
4.2.	CT/VT Config	132
4.3.	Function Config	133
4.4.	Current Prot'n	137
4.4.1.	Phase Overcurrent	137
4.4.1.1.	51-1	137
4.4.1.2.	51-2	138
4.4.1.3.	51-3	139
4.4.1.4.	51-4	140
4.4.1.5.	50-1	141
4.4.1.6.	50-2	141
4.4.1.7.	50-3	141
4.4.1.8.	50-4	142
4.4.2.	Voltage Cont O/C	142
4.4.3.	Cold Load	143

4.4.4.	Measured E/F	144
4.4.4.1.	51G-1	145
4.4.4.2.	51G-2	145
4.4.4.3.	51G-3	146
4.4.4.4.	51G-4	147
4.4.4.5.	50G-1	148
4.4.4.6.	50G-2	148
4.4.4.7.	50G-3	148
4.4.4.8.	50G-4	149
4.4.5.	Sensitive E/F	149
4.4.5.1.	51SEF-1	149
4.4.5.2.	51SEF-2	150
4.4.5.3.	51SEF-3	151
4.4.5.4.	51SEF-4	151
4.4.5.5.	50SEF-1	152
4.4.5.6.	50SEF-2	152
4.4.5.7.	50SEF-3	152
4.4.5.8.	50SEF-4	153
4.4.6.	Restricted E/F	153
4.4.7.	NPS Overcurrent	154
4.4.7.1.	46IT	154
4.4.7.2.	46DT	154
4.4.8.	Under Current	154
4.4.8.1.	37-1	154
4.4.8.2.	37-2	154
4.4.9.	Thermal	155
4.5.	Voltage Prot'n	155
4.5.1.	Phase U/O Voltage	155
4.5.1.1.	27/59-1	155
4.5.1.2.	27/59-2	156
4.5.1.3.	27/59-3	156
4.5.1.4.	27/59-4	157
4.5.2.	Vx U/O Voltage	157
4.5.3.	NPS Overvoltage	158
4.5.3.1.	47-1	158
4.5.3.2.	47-2	158
4.5.4.	Neutral Overvoltage	158
4.5.4.1.	59NIT	159
4.5.4.2.	59NDT	159
4.5.5.	U/O Frequency	159
4.5.5.1.	81-1	159
4.5.5.2.	81-2	160
4.5.5.3.	81-3	160
4.5.5.4.	81-4	161
4.6.	Supervision	161
4.6.1.	CB Fail	161
4.6.2.	VT Supervision	161
4.6.3.	162	
4.6.4.	CT Supervision	163
4.6.5.	Broken Conductor	163
4.6.6.	Trip CCT Supervision	163
4.6.7.	Inrush Detector	164
4.6.8.	Battery Test	164
4.6.9.	Capacitor Test	164
4.6.10.	Power Quality	165
4.6.11.	27SAG	165
4.6.12.	59SWELL	165
4.7.	Control & Logic	166
4.7.1.	Autoreclose Prot'n	166
4.7.2.	Autoreclose Config	167
4.7.2.1.	P/F Shots	168
4.7.2.2.	E/F Shots	168
4.7.2.3.	SEF Shots	169
4.7.2.4.	Extern Shots	170
4.7.3.	Manual Close	171
4.7.4.	Circuit Breaker	171
4.7.5.	LOV Automation	172

4.7.6.	Quick Logic	173
4.8.	Input Config	184
4.8.1.	Input Matrix	184
4.8.2.	Function Key Matrix	203
4.8.3.	Binary Input Config	204
4.8.4.	Function Key Config	206
4.8.5.	General Alarms	207
4.9.	Output Config	208
4.9.1.	Output Matrix	208
4.9.2.	Binary Output Config	244
4.9.3.	LED Config	246
4.9.4.	Pickup Config	246
4.10.	Maintenance	247
4.10.1.	CB Counters	247
4.10.2.	I ² T CB Wear	248
4.10.3.	Output Matrix Test	248
4.11.	Data Storage	248
4.11.1.	Demand/Data Log	248
4.11.2.	Waveform Storage	248
4.11.3.	Fault Storage	249
4.11.4.	Event Storage	249
4.11.5.	Energy Storage	249
4.12.	Communications	250
5.	Relay Settings – Standard Plus Single/Triple	252
5.1.	System Config	252
5.2.	CT/VT Config	254
5.3.	Function Config	255
5.4.	Current Prot'n	258
5.4.1.	Phase Overcurrent	258
5.4.1.1.	51-1	258
5.4.1.2.	51-2	259
5.4.1.3.	51-3	260
5.4.1.4.	51-4	260
5.4.1.5.	50-1	261
5.4.1.6.	50-2	261
5.4.1.7.	50-3	262
5.4.1.8.	50-4	262
5.4.2.	Voltage Cont O/C	263
5.4.3.	Cold Load	263
5.4.4.	Measured E/F	265
5.4.4.1.	51G-1	265
5.4.4.2.	51G-2	266
5.4.4.3.	51G-3	267
5.4.4.4.	51G-4	267
5.4.4.5.	50G-1	268
5.4.4.6.	50G-2	268
5.4.4.7.	50G-3	269
5.4.4.8.	50G-4	269
5.4.5.	Sensitive E/F	269
5.4.5.1.	51SEF-1	270
5.4.5.2.	51SEF-2	270
5.4.5.3.	51SEF-3	271
5.4.5.4.	51SEF-4	272
5.4.5.5.	50SEF-1	272
5.4.5.6.	50SEF-2	272
5.4.5.7.	50SEF-3	273
5.4.5.8.	50SEF-4	273
5.4.6.	Restricted E/F	273
5.4.7.	NPS Overcurrent	274
5.4.7.1.	46IT	274
5.4.7.2.	46DT	274
5.4.8.	Under Current	275
5.4.8.1.	37-1	275
5.4.8.2.	37-2	275
5.4.9.	Thermal	275
5.5.	Voltage Prot'n	275

5.5.1.	Phase U/O Voltage	275
	5.5.1.1. 27/59-1	276
	5.5.1.2. 27/59-2	276
	5.5.1.3. 27/59-3	277
	5.5.1.4. 27/59-4	277
5.5.2.	Vx U/O Voltage	278
5.5.3.	NPS Overvoltage	278
	5.5.3.1. 47-1	278
	5.5.3.2. 47-2	278
5.5.4.	Neutral Overvoltage	279
	5.5.4.1. 59NIT	279
	5.5.4.2. 59NDT	280
5.5.5.	U/O Frequency	280
	5.5.5.1. 81-1	280
	5.5.5.2. 81-2	280
	5.5.5.3. 81-3	281
	5.5.5.4. 81-4	281
5.6.	Supervision	282
5.6.1.	CB Fail	282
5.6.2.	VT Supervision	282
5.6.3.	CT Supervision	283
5.6.4.	Broken Conductor	283
5.6.5.	Trip CCT Supervision	283
5.6.6.	Inrush Detector	284
5.6.7.	Battery Test	284
5.6.8.	Capacitor Test	284
5.6.9.	Power Quality	285
5.6.10.	27SAG	285
5.6.11.	59SWELL	285
5.7.	Control & Logic	286
5.7.1.	Autoreclose Prot'n	286
5.7.2.	Autoreclose Config	287
	5.7.2.1. P/F Shots	288
	5.7.2.2. E/F Shots	289
	5.7.2.3. SEF Shots	290
	5.7.2.4. Extern Shots	290
5.7.3.	Manual Close	291
5.7.4.	Circuit Breaker	291
5.7.5.	Quick Logic	292
5.8.	Input Config	302
5.8.1.	Input Matrix	302
5.8.2.	Function Key Matrix	336
5.8.3.	Binary Input Config	338
5.8.4.	Function Key Config	342
5.8.5.	General Alarms	343
5.9.	Output Config	344
5.9.1.	Output Matrix	344
5.9.2.	Binary Output Config	406
5.9.3.	LED Config	408
5.9.4.	Pickup Config	408
5.10.	Maintenance	409
5.10.1.	CB Counters	409
5.10.2.	I ² T CB Wear	412
5.10.3.	Output Matrix Test	412
5.11.	Data Storage	413
5.11.1.	Demand/Data Log	413
5.11.2.	Waveform Storage	413
5.11.3.	Fault Storage	414
5.11.4.	Event Storage	414
5.11.5.	Energy Storage	414
5.12.	Communications	415
6.	Relay Instrumentation	417

1. Function Diagram

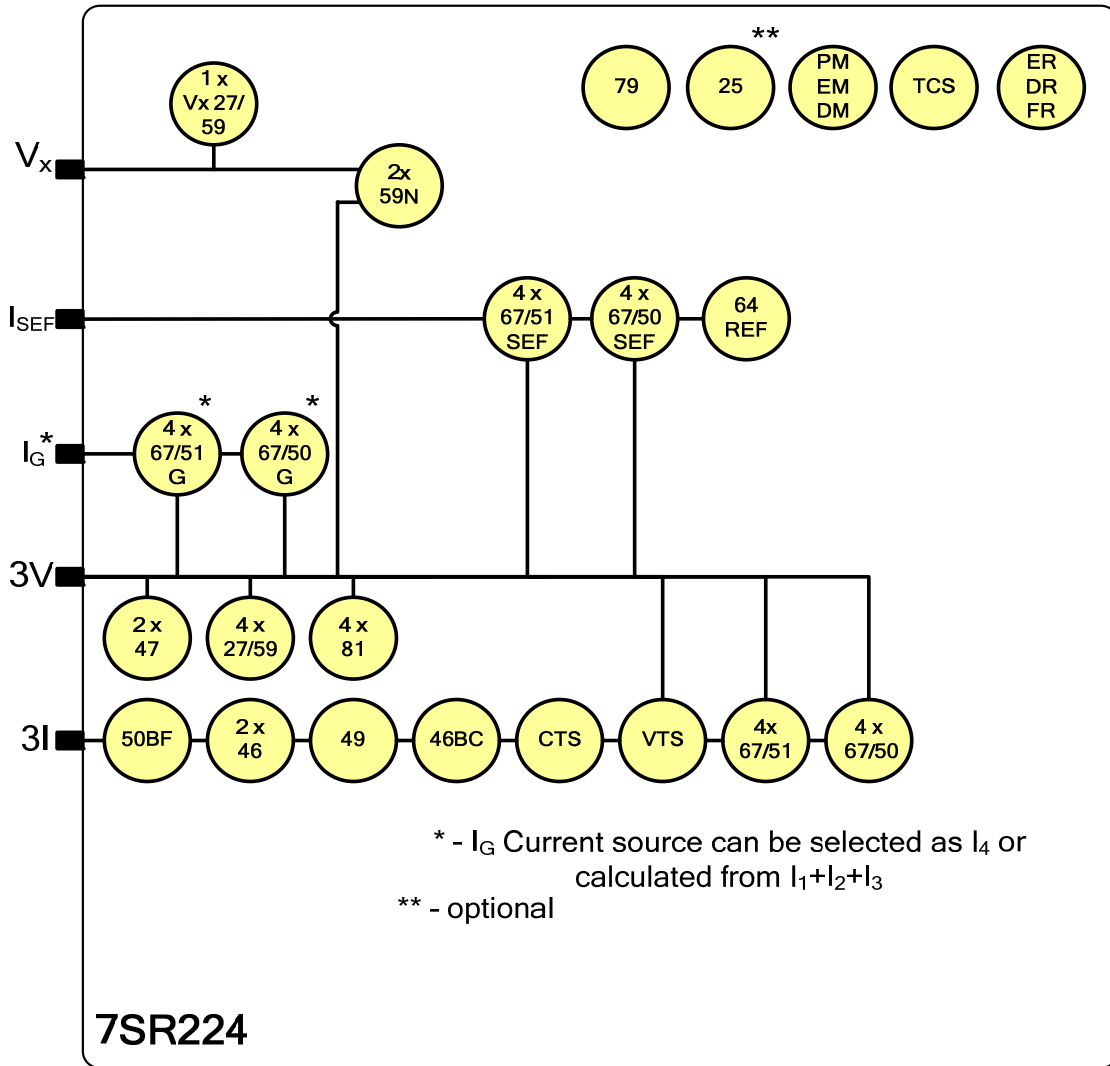

2. Menu Structure

2.1. Standard

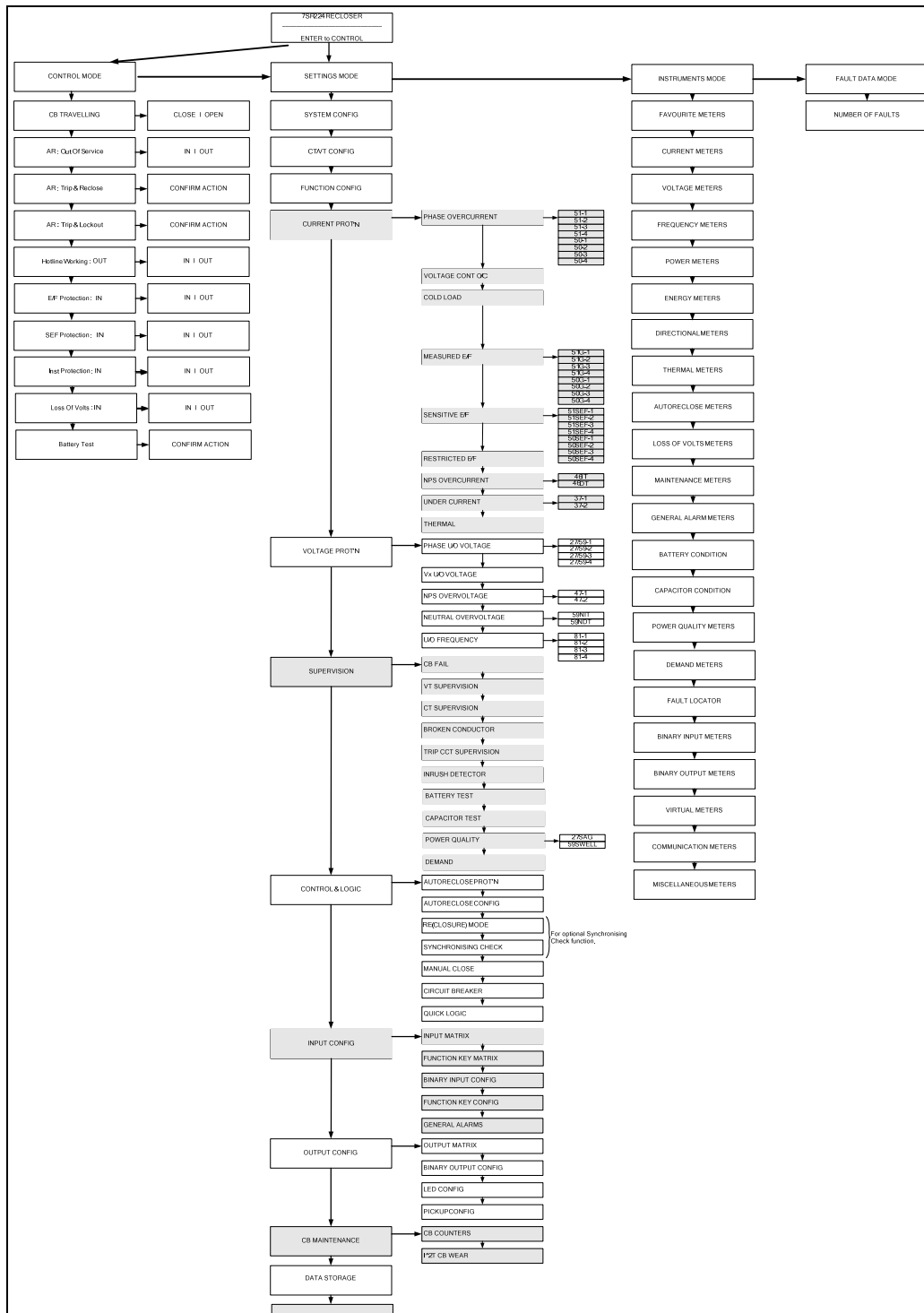

2.2. Loss Of Voltage

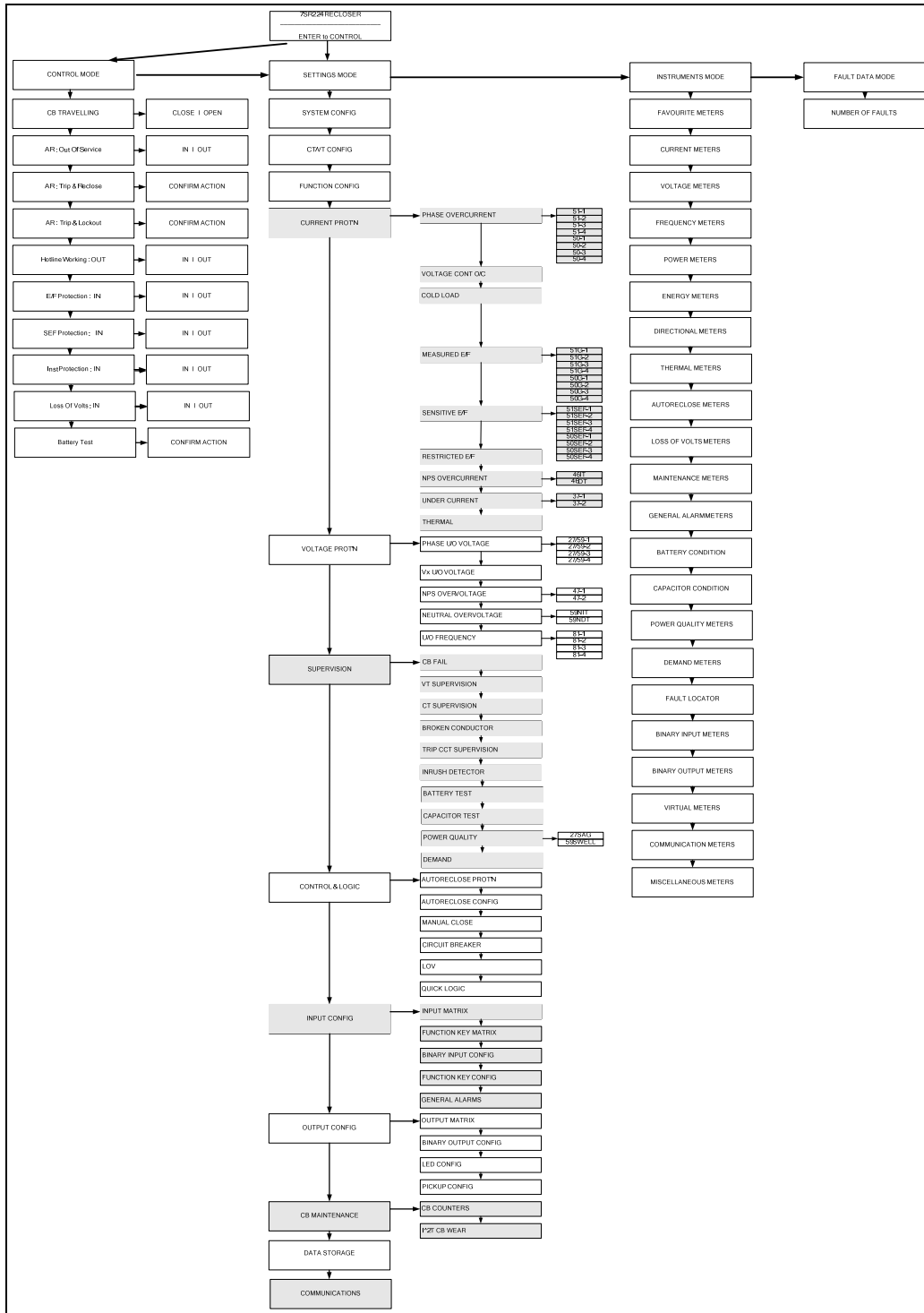

2.3. Single/Triple

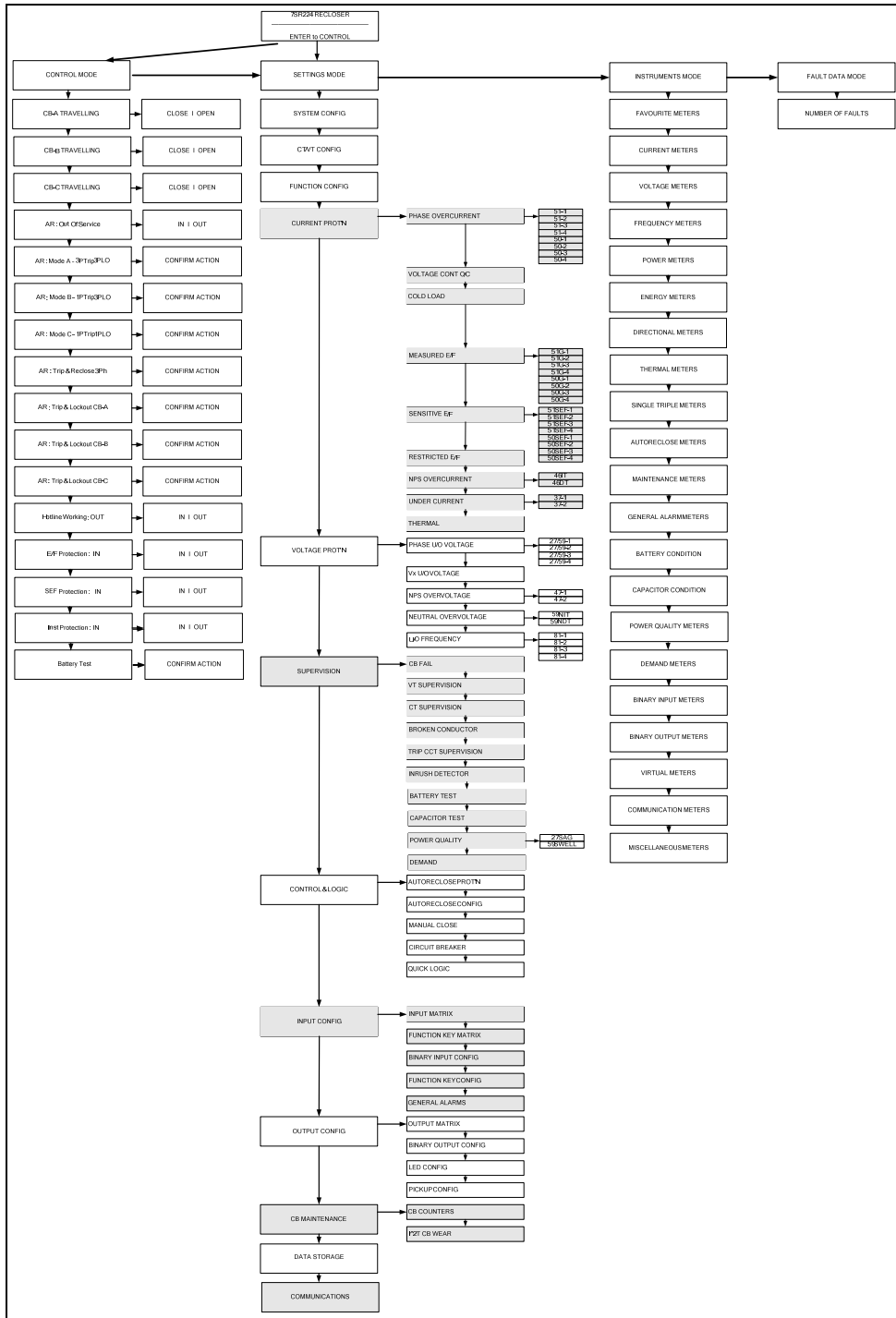

3. Relay Settings – Standard

3.1. System Config

Description	Range	Default	Setting
Language Setting <i>Selects the language in which the relay text will be displayed.</i>	English, USA-English	English	
Active Group <i>Selects which settings group is currently activated</i>			
System Frequency <i>Selects the Power System Frequency from 50 or 60 Hz</i>	50, 60	50Hz	
View/Edit Group <i>Selects which settings group is currently being displayed</i>			
Setting Dependencies <i>When enabled only active settings are displayed and all others hidden</i>	Disabled, Enabled	Enabled	
Favourite Meters Timer <i>Selects the time delay after which, if no key presses have been detected, the relay will begin to poll through any screens which have been selected as favourite instruments</i>	Off, 1, 2, 5, 10, 15, 30, 60	60min	
Backlight timer <i>Controls when the LCD backlight turns off</i>	Off, 1, 2, 5, 10, 15, 30, 60	5min	
Date <i>Sets the date, this setting can only be changed on the fascia or via Relay->Control->Set Time and Date</i>			
Time <i>Sets the time, this setting can only be changed on the fascia or via Relay->Control->Set Time and Date</i>			
Curr Set Display <i>Select whether the Pickup values are shown in terms of x Nominal, Primary or Secondary values on the Relay Fascia</i>	xNom, Primary, Secondary	xNom	
E/F Curr Set Display <i>As Above</i>	xNom, Primary, Secondary	xNom	
Export Power/Lag VAR <i>Selects the signs required for exporting power and lagging VARs</i>	+ve/+ve, +ve/-ve, -ve/+ve, -ve/-ve	+ve/+ve	
Select Grp Mode <i>Mode of operation of the group change from status input. Edge triggered ignores the status input once it has changed to the relevant group, where as with Level triggered the relay will only stay in the group it has changed to whilst the status input is being driven, after which it returns to the previous group.</i>	Edge triggered, Level triggered	Edge triggered	

Description	Range	Default	Setting
Clock Sync. From BI <i>Real time clock may be synchronised using a binary input (See Clock Sync. in Binary Input Menu)</i>	Disabled, Seconds, Minutes	Minutes	
Operating Mode <i>Selects the current operating mode of the relay. This can also be changed by a binary input mode selection.</i>	Out Of Service, Local, Remote, Local Or Remote	Local Or Remote	
Setting Password <i>Allows a 4 character alpha code to be entered as the password. Note that the display shows a password dependant encrypted code on the second line of the display</i>	(Password)	NONE	
Control Password <i>As Above</i>	(Password)	NONE	
Trip Alert <i>When Enabled the occurrence of a Trip will cause the relay to display the Trip Alert Screen, the only way to leave this screen is by acknowledging the trip through the TEST/RESET button on the relay fascia</i>	Disabled, Enabled	Enabled	
General Alarm Alert <i>When Enabled the occurrence of a General Alarm will cause the relay to display the General Alarm Screen, any relay fascia button being pressed will cancel this action and revert to the last screen being displayed prior to the alarm</i>	Disabled, Enabled	Enabled	
Relay Identifier <i>An alphanumeric string shown on the LCD normally used to identifier the circuit the relay is attached to or the relays purpose</i>	(16 Character String)	7SR224	
Circuit Identifier <i>An alphanumeric string shown on the LCD normally used to identify the circuit name or relay's purpose</i>	(16 Character String)		

3.2. CT/VT Config

Description	Range	Default	Setting
Phase Nom Voltage <i>Selects the nominal voltage setting Vn of the voltage input</i>	40, 40.1 ... 159.9, 160	63.5V	
Phase Voltage Trim Magnitude <i>Allows trimming of voltage magnitude, the setting value should be the voltage required to be added to get back to Phase Nom Voltage.</i>	0, 0.1 ... 19.9, 20	0V	
Phase Voltage Trim Angle <i>Allows trimming of voltage angle, the setting value is added to the current voltage angle</i>	-45, -44.9 ... 44.9, 45	0deg	
Phase Voltage Config <i>Required to allow for different types of physical VT connections.</i>	Van,Vbn,Vcn, Vab,Vbc,3V0, Va,Vb,Vc	Van,Vbn,Vcn	

Description	Range	Default	Setting
Phase VT Ratio Prim <i>VT ratio Primary value, used to scale primary voltage instruments</i>	(6 Character String)	132000	
Phase VT Ratio Sec <i>VT ratio Secondary value, used to scale primary voltage instruments</i>	40, 40.5 ... 159.5, 160	110	
Vx Nom Voltage <i>Selects the nominal voltage setting Vn of the voltage input</i>	40, 40.1 ... 159.9, 160	63.5V	
Vx Voltage Trim Magnitude <i>Allows trimming of voltage magnitude, the setting value should be the voltage required to be added to get back to Vx Nom Voltage.</i>	0, 0.1 ... 19.9, 20	0V	
Vx Voltage Trim Angle <i>Allows trimming of voltage angle, the setting value is added to the current voltage angle</i>	-45, -44.9 ... 44.9, 45	0deg	
Vx VT Ratio Prim <i>VT ratio Primary value, used to scale primary voltage instruments</i>	(6 Character String)	132000	
Vx VT Ratio Sec <i>VT ratio Secondary value, used to scale primary voltage instruments</i>	40, 40.5 ... 159.5, 160	110	
Phase Current Input <i>Selects whether 1 or 5 Amp terminals are being used for phase inputs</i>	1, 5	1A	
Phase CT Ratio <i>Phase CT ratio to scale primary current instruments</i>	1:0.2, 1:0.21 ... 5000:6.9, 5000:7	2000:1	
Earth Current Input <i>Selects whether 1 or 5 Amp terminals are being used for Measured Earth inputs</i>	1, 5	1A	
Earth CT Ratio <i>Measured Earth CT ratio to scale primary current instruments</i>	1:0.2, 1:0.21 ... 5000:6.9, 5000:7	2000:1	
I1, I2, I3 Connections <i>Allocates phase reference letters to the relay hardware current inputs</i>	ABC, ACB, BAC, BCA, CAB,CBA	ABC	
V1, V2, V3 Connections <i>Allocates phase reference letters to the relay hardware voltage inputs</i>	ABC, ACB, BAC, BCA, CAB,CBA	ABC	
Phase Rotation <i>Specifies the vectorial positive phase sequence order of the allocated phase references. This setting allows the relay to be applied on networks with abnormal phasor sequence.</i>	A,B,C A,C,B	A,B,C	

3.3. Function Config

Description	Range	Default	Setting
Gn Phase Overcurrent <i>When set to Disabled, no Phase Overcurrent elements will be functional and all associated settings will be hidden. (The Setting Dependencies setting being set to Disabled will make all settings visible but will not allow them to operate).</i>	Enabled, Disabled	Disabled	
Gn Voltage Cont O/C <i>When set to Disabled, no Voltage Cont O/C elements will be functional and all associated settings will be hidden. (The Setting Dependencies setting being set to Disabled will make all settings visible but will not allow them to operate).</i>	Enabled, Disabled	Disabled	
Gn Cold Load <i>When set to Disabled, no Cold Load elements will be functional and all associated settings will be hidden. (The Setting Dependencies setting being set to Disabled will make all settings visible but will not allow them to operate).</i>	Enabled, Disabled	Disabled	
Gn Measured E/F <i>When set to Disabled, no Measured E/F elements will be functional and all associated settings will be hidden. (The Setting Dependencies setting being set to Disabled will make all settings visible but will not allow them to operate).</i>	Enabled, Disabled	Disabled	
Gn Sensitive E/F <i>When set to Disabled, no Sensitive E/F elements will be functional and all associated settings will be hidden. (The Setting Dependencies setting being set to Disabled will make all settings visible but will not allow them to operate).</i>	Enabled, Disabled	Disabled	
Gn Restricted E/F <i>When set to Disabled, no Restricted E/F elements will be functional and all associated settings will be hidden. (The Setting Dependencies setting being set to Disabled will make all settings visible but will not allow them to operate).</i>	Enabled, Disabled	Disabled	
Gn NPS Overcurrent <i>When set to Disabled, no NPS Overcurrent elements will be functional and all associated settings will be hidden. (The Setting Dependencies setting being set to Disabled will make all settings visible but will not allow them to operate).</i>	Enabled, Disabled	Disabled	
Gn Under Current <i>When set to Disabled, no Under Current elements will be functional and all associated settings will be hidden. (The Setting Dependencies setting being set to Disabled will make all settings visible but will not allow them to operate).</i>	Enabled, Disabled	Disabled	

Description	Range	Default	Setting
Gn Thermal <i>When set to Disabled, no Thermal elements will be functional and all associated settings will be hidden. (The Setting Dependencies setting being set to Disabled will make all settings visible but will not allow them to operate).</i>	Enabled, Disabled	Disabled	
Gn Phase U/O Voltage <i>When set to Disabled, no Phase U/O Voltage elements will be functional and all associated settings will be hidden. (The Setting Dependencies setting being set to Disabled will make all settings visible but will not allow them to operate).</i>	Enabled, Disabled	Disabled	
Gn Vx U/O Voltage <i>When set to Disabled, no Vx U/O Voltage elements will be functional and all associated settings will be hidden. (The Setting Dependencies setting being set to Disabled will make all settings visible but will not allow them to operate).</i>	Enabled, Disabled	Disabled	
Gn NPS Overvoltage <i>When set to Disabled, no NPS Overvoltage elements will be functional and all associated settings will be hidden. (The Setting Dependencies setting being set to Disabled will make all settings visible but will not allow them to operate).</i>	Enabled, Disabled	Disabled	
Gn Neutral Overvoltage <i>When set to Disabled, no Neutral Overvoltage elements will be functional and all associated settings will be hidden. (The Setting Dependencies setting being set to Disabled will make all settings visible but will not allow them to operate).</i>	Enabled, Disabled	Disabled	
Gn U/O Frequency <i>When set to Disabled, no U/O Frequency elements will be functional and all associated settings will be hidden. (The Setting Dependencies setting being set to Disabled will make all settings visible but will not allow them to operate).</i>	Enabled, Disabled	Disabled	
Gn CB Fail <i>When set to Disabled, no CB Fail elements will be functional and all associated settings will be hidden. (The Setting Dependencies setting being set to Disabled will make all settings visible but will not allow them to operate).</i>	Enabled, Disabled	Disabled	
Gn VT Supervision <i>When set to Disabled, no VT Supervision elements will be functional and all associated settings will be hidden. (The Setting Dependencies setting being set to Disabled will make all settings visible but will not allow them to operate).</i>	Enabled, Disabled	Disabled	

Description	Range	Default	Setting
Gn CT Supervision <i>When set to Disabled, no CT Supervision elements will be functional and all associated settings will be hidden. (The Setting Dependencies setting being set to Disabled will make all settings visible but will not allow them to operate).</i>	Enabled, Disabled	Disabled	
Gn Broken Conductor <i>When set to Disabled, no Broken Conductor elements will be functional and all associated settings will be hidden. (The Setting Dependencies setting being set to Disabled will make all settings visible but will not allow them to operate).</i>	Enabled, Disabled	Disabled	
Gn Trip Cct Supervision <i>When set to Disabled, no Trip Cct Supervision elements will be functional and all associated settings will be hidden. (The Setting Dependencies setting being set to Disabled will make all settings visible but will not allow them to operate).</i>	Enabled, Disabled	Disabled	
Gn Inrush Detector <i>When set to Disabled, no Inrush Detector elements will be functional and all associated settings will be hidden. (The Setting Dependencies setting being set to Disabled will make all settings visible but will not allow them to operate).</i>	Enabled, Disabled	Disabled	
Gn CB Counters <i>When set to Disabled, no Gn CB Counter elements will be functional and all associated settings will be hidden. (The Setting Dependencies setting being set to Disabled will make all settings visible but will not allow them to operate).</i>	Enabled, Disabled	Disabled	
Gn I ² t CB Wear <i>When set to Disabled, no Gn I²t CB Wear elements will be functional and all associated settings will be hidden. (The Setting Dependencies setting being set to Disabled will make all settings visible but will not allow them to operate).</i>	Enabled, Disabled	Disabled	
Gn Battery Test <i>When set to Disabled, no Battery Test elements will be functional and all associated settings will be hidden. (The Setting Dependencies setting being set to Disabled will make all settings visible but will not allow them to operate).</i>	Enabled, Disabled	Disabled	
Gn Capacitor Test <i>When set to Disabled, no Capacitor Test elements will be functional and all associated settings will be hidden. (The Setting Dependencies setting being set to Disabled will make all settings visible but will not allow them to operate).</i>	Enabled, Disabled	Disabled	

Description	Range	Default	Setting
Gn 27Sag & 59Swell <i>When set to Disabled, no 27Sag & 59Swell elements will be functional and all associated settings will be hidden. (The Setting Dependencies setting being set to Disabled will make all settings visible but will not allow them to operate).</i>	Enabled, Disabled	Disabled	

3.4. Current Prot'n

3.4.1. Phase Overcurrent

Description	Range	Default	Setting
Gn 67 Char Angle <i>Maximum torque angle for phase overcurrent elements</i>	-95, -94 ... 94, 95	45deg	
Gn 67 Minimum Voltage <i>Selects the directional elements minimum voltage, below which the element will be inhibited</i>	1, 1.5 ... 19.5, 20	1V	
Gn 67 2-out-of-3 Logic <i>Selects whether 2 out of 3 voting logic is enabled for phase overcurrent elements</i>	Enabled, Disabled	Disabled	
Gn 51/50 Measurement <i>Selects whether the RMS value used by the 51 & 50 elements is True RMS or only calculated at fundamental frequency</i>	RMS, Fundamental	RMS	

3.4.1.1. 51-1

Description	Range	Default	Setting
Gn 51-1 Element <i>Selects whether the 51-1 IDMTL Overcurrent element is enabled</i>	Disabled, Enabled	Disabled	
Gn 51-1 Dir. Control <i>Selects whether 51-1 element is non-directional, forward or reverse</i>	Non-Dir, Forward, Reverse	Non-Dir	
Gn 51-1 Setting <i>Pickup level</i>	0.05, 0.06 ... 2.49, 2.5	1xIn	
Gn 51-1 Char <i>Selects characteristic curve to be IEC or ANSI IDMTL or DTL</i>	DTL, IEC-NI ... 201, 202	IEC-NI	
Gn 51-1 Time Mult (IEC/ANSI) <i>Time multiplier (applicable to IEC and ANSI curves but not DTL selection)</i>	0.025, 0.05 ... 1.575, 1.6	1	
Gn 51-1 Delay (DTL) <i>Delay (applicable only when DTL is selected for characteristic)</i>	0, 0.01 ... 19.99, 20	5s	
Gn 51-1 Min Operate Time <i>Minimum operate time of element.</i>	0, 0.01 ... 19.99, 20	0s	
Gn 51-1 Follower DTL <i>Additional definite time added after characteristic time</i>	0, 0.01 ... 19.99, 20	0s	

Description	Range	Default	Setting
Gn 51-1 Reset <i>Selects between an ANSI decaying reset characteristic or a definite time reset</i>	(ANSI) Decaying, 0 ... 59, 60	0s	
Gn 51-1 VTS Action <i>Selects whether 51-1 element is blocked or made non-directional when VTS operates</i>	Off, Inhibit, Non-Dir	Off	
Gn 51-1 Inrush Action <i>Selects if the 51-1 element is blocked from operating when 2nd Harmonic Inrush Detector operates</i>	Off, Inhibit	Off	

3.4.1.2. 51-2

Description	Range	Default	Setting
Gn 51-2 Element <i>Selects whether the 51-2 IDMTL Overcurrent element is enabled</i>	Disabled, Enabled	Disabled	
Gn 51-2 Dir. Control <i>Selects whether 51-2 element is non-directional, forward or reverse</i>	Non-Dir, Forward, Reverse	Non-Dir	
Gn 51-2 Setting <i>Pickup level</i>	0.05, 0.06 ... 2.49, 2.5	1xIn	
Gn 51-2 Char <i>Selects characteristic curve to be IEC or ANSI IDMTL or DTL</i>	DTL, IEC-NI ... 201, 202	IEC-NI	
Gn 51-2 Time Mult (IEC/ANSI) <i>Time multiplier (applicable to IEC and ANSI curves but not DTL selection)</i>	0.025, 0.05 ... 1.575, 1.6	1	
Gn 51-2 Delay (DTL) <i>Delay (applicable only when DTL is selected for characteristic)</i>	0, 0.01 ... 19.99, 20	5s	
Gn 51-2 Min Operate Time <i>Minimum operate time of element.</i>	0, 0.01 ... 19.99, 20	0s	
Gn 51-2 Follower DTL <i>Additional definite time added after characteristic time</i>	0, 0.01 ... 19.99, 20	0s	
Gn 51-2 Reset <i>Selects between an ANSI decaying reset characteristic or a definite time reset</i>	(ANSI) Decaying, 0 ... 59, 60	0s	
Gn 51-2 VTS Action <i>Selects whether 51-2 element is blocked or made non-directional when VTS operates</i>	Off, Inhibit, Non-Dir	Off	
Gn 51-2 Inrush Action <i>Selects if the 51-2 element is blocked from operating when 2nd Harmonic Inrush Detector operates</i>	Off, Inhibit	Off	

3.4.1.3. 51-3

Description	Range	Default	Setting
Gn 51-3 Element <i>Selects whether the 51-3 IDMTL Overcurrent element is enabled</i>	Disabled, Enabled	Disabled	

Description	Range	Default	Setting
Gn 51-3 Dir. Control <i>Selects whether 51-3 element is non-directional, forward or reverse</i>	Non-Dir, Forward, Reverse	Non-Dir	
Gn 51-3 Setting <i>Pickup level</i>	0.05, 0.06 ... 2.49, 2.5	1xIn	
Gn 51-3 Char <i>Selects characteristic curve to be IEC or ANSI IDMTL or DTL</i>	DTL, IEC-NI ... 201, 202	IEC-NI	
Gn 51-3 Time Mult (IEC/ANSI) <i>Time multiplier (applicable to IEC and ANSI curves but not DTL selection)</i>	0.025, 0.05 ... 1.575, 1.6	1	
Gn 51-3 Delay (DTL) <i>Delay (applicable only when DTL is selected for characteristic)</i>	0, 0.01 ... 19.99, 20	5s	
Gn 51-3 Min Operate Time <i>Minimum operate time of element.</i>	0, 0.01 ... 19.99, 20	0s	
Gn 51-3 Follower DTL <i>Additional definite time added after characteristic time</i>	0, 0.01 ... 19.99, 20	0s	
Gn 51-3 Reset <i>Selects between an ANSI decaying reset characteristic or a definite time reset</i>	(ANSI) Decaying, 0 ... 59, 60	0s	
Gn 51-3 VTS Action <i>Selects whether 51-3 element is blocked or made non-directional when VTS operates</i>	Off, Inhibit, Non-Dir	Off	
Gn 51-3 Inrush Action <i>Selects if the 51-3 element is blocked from operating when 2nd Harmonic Inrush Detector operates</i>	Off, Inhibit	Off	

3.4.1.4. 51-4

Description	Range	Default	Setting
Gn 51-4 Element <i>Selects whether the 51-4 IDMTL Overcurrent element is enabled</i>	Disabled, Enabled	Disabled	
Gn 51-4 Dir. Control <i>Selects whether 51-4 element is non-directional, forward or reverse</i>	Non-Dir, Forward, Reverse	Non-Dir	
Gn 51-4 Setting <i>Pickup level</i>	0.05, 0.06 ... 2.49, 2.5	1xIn	
Gn 51-4 Char <i>Selects characteristic curve to be IEC or ANSI IDMTL or DTL</i>	DTL, IEC-NI ... 201, 202	IEC-NI	
Gn 51-4 Time Mult (IEC/ANSI) <i>Time multiplier (applicable to IEC and ANSI curves but not DTL selection)</i>	0.025, 0.05 ... 1.575, 1.6	1	
Gn 51-4 Delay (DTL) <i>Delay (applicable only when DTL is selected for characteristic)</i>	0, 0.01 ... 19.99, 20	5s	
Gn 51-4 Min Operate Time <i>Minimum operate time of element.</i>	0, 0.01 ... 19.99, 20	0s	

Description	Range	Default	Setting
Gn 51-4 Follower DTL <i>Additional definite time added after characteristic time</i>	0, 0.01 ... 19.99, 20	0s	
Gn 51-4 Reset <i>Selects between an ANSI decaying reset characteristic or a definite time reset</i>	(ANSI) Decaying, 0 ... 59, 60	0s	
Gn 51-4 VTS Action <i>Selects whether 51-4 element is blocked or made non-directional when VTS operates</i>	Off, Inhibit, Non-Dir	Off	
Gn 51-4 Inrush Action <i>Selects if the 51-4 element is blocked from operating when 2nd Harmonic Inrush Detector operates</i>	Off, Inhibit	Off	

3.4.1.5. 50-1

Description	Range	Default	Setting
Gn 50-1 Element <i>Selects whether the INST/ DTL Overcurrent element is enabled</i>	Disabled, Enabled	Disabled	
Gn 50-1 Dir. Control <i>Selects whether 50-1 element is non-directional, forward or reverse</i>	Non-Dir, Forward, Reverse	Non-Dir	
Gn 50-1 Setting <i>Pickup level</i>	0.05, 0.06 ... 49.5, 50	1xIn	
Gn 50-1 Delay <i>Sets operate delay time</i>	0, 0.01 ... 14300, 14400	0s	
Gn 50-1 VTS Action <i>Selects whether 50-1 element is blocked or made non-directional when VTS operates</i>	Off, Inhibit, Non-Dir	Off	
Gn 50-1 Inrush Action <i>Selects if the 50-1 element is blocked from operating when 2nd Harmonic Inrush Detector operates</i>	Off, Inhibit	Off	

3.4.1.6. 50-2

Description	Range	Default	Setting
Gn 50-2 Element <i>Selects whether the INST/ DTL Overcurrent element is enabled</i>	Disabled, Enabled	Disabled	
Gn 50-2 Dir. Control <i>Selects whether 50-2 element is non-directional, forward or reverse</i>	Non-Dir, Forward, Reverse	Non-Dir	
Gn 50-2 Setting <i>Pickup level</i>	0.05, 0.06 ... 49.5, 50	1xIn	
Gn 50-2 Delay <i>Sets operate delay time</i>	0, 0.01 ... 14300, 14400	0s	
Gn 50-2 VTS Action <i>Selects whether 50-2 element is blocked or made non-directional when VTS operates</i>	Off, Inhibit, Non-Dir	Off	
Gn 50-2 Inrush Action <i>Selects if the 50-2 element is blocked from operating when 2nd Harmonic Inrush Detector operates</i>	Off, Inhibit	Off	

3.4.1.7. 50-3

Description	Range	Default	Setting
Gn 50-3 Element <i>Selects whether the INST/ DTL Overcurrent element is enabled</i>	Disabled, Enabled	Disabled	
Gn 50-3 Dir. Control <i>Selects whether 50-3 element is non-directional, forward or reverse</i>	Non-Dir, Forward, Reverse	Non-Dir	
Gn 50-3 Setting <i>Pickup level</i>	0.05, 0.06 ... 49.5, 50	1xIn	
Gn 50-3 Delay <i>Sets operate delay time</i>	0, 0.01 ... 14300, 14400	0s	
Gn 50-3 VTS Action <i>Selects whether 50-3 element is blocked or made non-directional when VTS operates</i>	Off, Inhibit, Non-Dir	Off	
Gn 50-3 Inrush Action <i>Selects if the 50-3 element is blocked from operating when 2nd Harmonic Inrush Detector operates</i>	Off, Inhibit	Off	

3.4.1.8. 50-4

Description	Range	Default	Setting
Gn 50-4 Element <i>Selects whether the INST/ DTL Overcurrent element is enabled</i>	Disabled, Enabled	Disabled	
Gn 50-4 Dir. Control <i>Selects whether 50-4 element is non-directional, forward or reverse</i>	Non-Dir, Forward, Reverse	Non-Dir	
Gn 50-4 Setting <i>Pickup level</i>	0.05, 0.06 ... 49.5, 50	1xIn	
Gn 50-4 Delay <i>Sets operate delay time</i>	0, 0.01 ... 14300, 14400	0s	
Gn 50-4 VTS Action <i>Selects whether 50-4 element is blocked or made non-directional when VTS operates</i>	Off, Inhibit, Non-Dir	Off	
Gn 50-4 Inrush Action <i>Selects if the 50-4 element is blocked from operating when 2nd Harmonic Inrush Detector operates</i>	Off, Inhibit	Off	

3.4.2. Voltage Cont O/C

Description	Range	Default	Setting
Gn 51V Element <i>Selects whether the Voltage Controlled Overcurrent element is enabled</i>	Disabled, Enabled	Disabled	
Gn 51V Setting <i>The voltage below which 51V operates</i>	5, 5.5 ... 199.5, 200	30V	
Gn 51V VTS Action <i>Selects whether or not the 51V element is blocked when VTS operates</i>	Off, Inhibit	Off	

Description	Range	Default	Setting
Gn 51-1 Multiplier <i>Multiplier applied to the 51-1 element when VCO element has operated</i>	0.25, 0.3, 0.35, 0.4, 0.45, 0.5, 0.55, 0.6, 0.65, 0.7, 0.75, 0.8, 0.85, 0.9, 0.95, 1	0.5	
Gn 51-2 Multiplier <i>Multiplier applied to the 51-2 element when VCO element has operated</i>	0.25, 0.3, 0.35, 0.4, 0.45, 0.5, 0.55, 0.6, 0.65, 0.7, 0.75, 0.8, 0.85, 0.9, 0.95, 1	0.5	
Gn 51-3 Multiplier <i>Multiplier applied to the 51-3 element when VCO element has operated</i>	0.25, 0.3, 0.35, 0.4, 0.45, 0.5, 0.55, 0.6, 0.65, 0.7, 0.75, 0.8, 0.85, 0.9, 0.95, 1	0.5	
Gn 51-4 Multiplier <i>Multiplier applied to the 51-4 element when VCO element has operated</i>	0.25, 0.3, 0.35, 0.4, 0.45, 0.5, 0.55, 0.6, 0.65, 0.7, 0.75, 0.8, 0.85, 0.9, 0.95, 1	0.5	

3.4.3. Cold Load

Description	Range	Default	Setting
Cold Load <i>Selects whether the Cold Load element is enabled</i>	Disabled, Enabled	Disabled	
Pick-up Time <i>Cold Load operate time delay</i>	1, 1.1 ... 14100, 14400	600s	
Drop-off Time <i>Cold Load reset time delay</i>	1, 1.1 ... 14100, 14400	600s	
Reduced Current <i>Selects whether reduced current functionality is to be used</i>	Disabled, Enabled	Disabled	
Reduced Current Level <i>Selects current level below which Reduced Current Time is used for Cold Load reset delay</i>	0.05, 0.1 ... 2.45, 2.5	0.25xIn	
Reduced Current Time <i>Cold Load reset time delay used when reduced current active</i>	1, 1.1 ... 14100, 14400	600s	
Gn 51c-1 Setting <i>51-1 element parameter used when Cold Load operates</i>	0.05, 0.06 ... 2.49, 2.5	1xIn	
Gn 51c-1 Char <i>As Above</i>	DTL, IEC-NI ... 201, 202	IEC-NI	
Gn 51c-1 Time Mult (IEC/ANSI) <i>As Above</i>	0.025, 0.05 ... 1.575, 1.6	1	
Gn 51c-1 Delay (DTL) <i>As Above</i>	0, 0.01 ... 19.99, 20	5s	
Gn 51c-1 Min Operate Time <i>As Above</i>	0, 0.01 ... 19.99, 20	0s	
Gn 51c-1 Follower DTL <i>As Above</i>	0, 0.01 ... 19.99, 20	0s	
Gn 51c-1 Reset <i>As Above</i>	(ANSI) Decaying, 0 ... 59, 60	0s	
Gn 51c-2 Setting <i>51-2 element parameter used when Cold Load operates</i>	0.05, 0.06 ... 2.49, 2.5	1xIn	

Description	Range	Default	Setting
Gn 51c-2 Char <i>As Above</i>	DTL, IEC-NI ... 201, 202	IEC-NI	
Gn 51c-2 Time Mult (IEC/ANSI) <i>As Above</i>	0.025, 0.05 ... 1.575, 1.6	1	
Gn 51c-2 Delay (DTL) <i>As Above</i>	0, 0.01 ... 19.99, 20	5s	
Gn 51c-2 Min Operate Time <i>As Above</i>	0, 0.01 ... 19.99, 20	0s	
Gn 51c-2 Follower DTL <i>As Above</i>	0, 0.01 ... 19.99, 20	0s	
Gn 51c-2 Reset <i>As Above</i>	(ANSI) Decaying, 0 ... 59, 60	0s	
Gn 51c-3 Setting <i>51-3 element parameter used when Cold Load operates</i>	0.05, 0.06 ... 2.49, 2.5	1xIn	
Gn 51c-3 Char <i>As Above</i>	DTL, IEC-NI ... 201, 202	IEC-NI	
Gn 51c-3 Time Mult (IEC/ANSI) <i>As Above</i>	0.025, 0.05 ... 1.575, 1.6	1	
Gn 51c-3 Delay (DTL) <i>As Above</i>	0, 0.01 ... 19.99, 20	5s	
Gn 51c-3 Min Operate Time <i>As Above</i>	0, 0.01 ... 19.99, 20	0s	
Gn 51c-3 Follower DTL <i>As Above</i>	0, 0.01 ... 19.99, 20	0s	
Gn 51c-3 Reset <i>As Above</i>	(ANSI) Decaying, 0 ... 59, 60	0s	
Gn 51c-4 Setting <i>51-4 element parameter used when Cold Load operates</i>	0.05, 0.06 ... 2.49, 2.5	1xIn	
Gn 51c-4 Char <i>As Above</i>	DTL, IEC-NI ... 201, 202	IEC-NI	
Gn 51c-4 Time Mult (IEC/ANSI) <i>As Above</i>	0.025, 0.05 ... 1.575, 1.6	1	
Gn 51c-4 Delay (DTL) <i>As Above</i>	0, 0.01 ... 19.99, 20	5s	
Gn 51c-4 Min Operate Time <i>As Above</i>	0, 0.01 ... 19.99, 20	0s	
Gn 51c-4 Follower DTL <i>As Above</i>	0, 0.01 ... 19.99, 20	0s	
Gn 51c-4 Reset <i>As Above</i>	(ANSI) Decaying, 0 ... 59, 60	0s	

3.4.4. Measured E/F

Description	Range	Default	Setting
Gn 67G Char Angle <i>Maximum torque angle for measured earth fault elements</i>	-95, -94 ... 94, 95	-15deg	
Gn 67G Minimum Voltage <i>Selects the directional elements minimum voltage, below which the element will be inhibited</i>	0.33, 0.5, 1, 1.5, 2, 2.5, 3	0.33V	
Gn 51G/50G Measurement <i>Selects whether the RMS value used by the 51G & 50G elements is True RMS or only calculated at fundamental frequency. Calculated setting switches the current source from measured at I_4 to derived from sum of I_1-I_3</i>	RMS, Fundamental, Calculated	RMS	

3.4.4.1. 51G-1

Description	Range	Default	Setting
Gn 51G-1 Element <i>Selects whether the 51G-1 IDMTL measured Earth Fault element is enabled</i>	Disabled, Enabled	Disabled	
Gn 51G-1 Dir. Control <i>Selects whether 51G-1 element is non-directional, forward or reverse</i>	Non-Dir, Forward, Reverse	Non-Dir	
Gn 51G-1 Setting <i>Pickup level</i>	0.005, 0.006 ... 0.995, 1	0.5xIn	
Gn 51G-1 Char <i>Selects characteristic curve to be IEC or ANSI IDMTL or DTL</i>	DTL, IEC-NI ... 201, 202	IEC-NI	
Gn 51G-1 Time Mult (IEC/ANSI) <i>Time multiplier (applicable to IEC and ANSI curves but not DTL selection)</i>	0.025, 0.05 ... 1.575, 1.6	1	
Gn 51G-1 Delay (DTL) <i>Delay (applicable only when DTL is selected for characteristic)</i>	0, 0.01 ... 19.99, 20	5s	
Gn 51G-1 Min Operate Time <i>Minimum operate time of element.</i>	0, 0.01 ... 19.99, 20	0s	
Gn 51G-1 Follower DTL <i>Additional definite time added after characteristic time</i>	0, 0.01 ... 19.99, 20	0s	
Gn 51G-1 Reset <i>Selects between an ANSI decaying reset characteristic or DTL reset</i>	(ANSI) Decaying, 0 ... 59, 60	0s	
Gn 51G-1 VTS Action <i>Selects whether 51G-1 element is blocked or made non-directional when VTS operates</i>	Off, Inhibit, Non-Dir	Off	
Gn 51G-1 Inrush Action <i>Selects if the 51G-1 element is blocked from operating when 2nd Harmonic Inrush Detector operates</i>	Off, Inhibit	Off	

3.4.4.2. 51G-2

Description	Range	Default	Setting
Gn 51G-2 Element <i>Selects whether the 51G-2 IDMTL measured Earth Fault element is enabled</i>	Disabled, Enabled	Disabled	
Gn 51G-2 Dir. Control <i>Selects whether 51G-2 element is non-directional, forward or reverse</i>	Non-Dir, Forward, Reverse	Non-Dir	
Gn 51G-2 Setting <i>Pickup level</i>	0.005, 0.006 ... 0.995, 1	0.5xIn	
Gn 51G-2 Char <i>Selects characteristic curve to be IEC or ANSI IDMTL or DTL</i>	DTL, IEC-NI ... 201, 202	IEC-NI	
Gn 51G-2 Time Mult (IEC/ANSI) <i>Time multiplier (applicable to IEC and ANSI curves but not DTL selection)</i>	0.025, 0.05 ... 1.575, 1.6	1	
Gn 51G-2 Delay (DTL) <i>Delay (applicable only when DTL is selected for characteristic)</i>	0, 0.01 ... 19.99, 20	5s	
Gn 51G-2 Min Operate Time <i>Minimum operate time of element.</i>	0, 0.01 ... 19.99, 20	0s	
Gn 51G-2 Follower DTL <i>Additional definite time added after characteristic time</i>	0, 0.01 ... 19.99, 20	0s	
Gn 51G-2 Reset <i>Selects between an ANSI decaying reset characteristic or DTL reset</i>	(ANSI) Decaying, 0 ... 59, 60	0s	
Gn 51G-2 VTS Action <i>Selects whether 51G-2 element is blocked or made non-directional when VTS operates</i>	Off, Inhibit, Non-Dir	Off	
Gn 51G-2 Inrush Action <i>Selects if the 51G-2 element is blocked from operating when 2nd Harmonic Inrush Detector operates</i>	Off, Inhibit	Off	

3.4.4.3. 51G-3

Description	Range	Default	Setting
Gn 51G-3 Element <i>Selects whether the 51G-3 IDMTL measured Earth Fault element is enabled</i>	Disabled, Enabled	Disabled	
Gn 51G-3 Dir. Control <i>Selects whether 51G-3 element is non-directional, forward or reverse</i>	Non-Dir, Forward, Reverse	Non-Dir	
Gn 51G-3 Setting <i>Pickup level</i>	0.005, 0.006 ... 0.995, 1	0.5xIn	
Gn 51G-3 Char <i>Selects characteristic curve to be IEC or ANSI IDMTL or DTL</i>	DTL, IEC-NI ... 201, 202	IEC-NI	
Gn 51G-3 Time Mult (IEC/ANSI) <i>Time multiplier (applicable to IEC and ANSI curves but not DTL selection)</i>	0.025, 0.05 ... 1.575, 1.6	1	

Description	Range	Default	Setting
Gn 51G-3 Delay (DTL) <i>Delay (applicable only when DTL is selected for characteristic)</i>	0, 0.01 ... 19.99, 20	5s	
Gn 51G-3 Min Operate Time <i>Minimum operate time of element.</i>	0, 0.01 ... 19.99, 20	0s	
Gn 51G-3 Follower DTL <i>Additional definite time added after characteristic time</i>	0, 0.01 ... 19.99, 20	0s	
Gn 51G-3 Reset <i>Selects between an ANSI decaying reset characteristic or DTL reset</i>	(ANSI) Decaying, 0 ... 59, 60	0s	
Gn 51G-3 VTS Action <i>Selects whether 51G-3 element is blocked or made non-directional when VTS operates</i>	Off, Inhibit, Non-Dir	Off	
Gn 51G-3 Inrush Action <i>Selects if the 51G-3 element is blocked from operating when 2nd Harmonic Inrush Detector operates</i>	Off, Inhibit	Off	

3.4.4.4. 51G-4

Description	Range	Default	Setting
Gn 51G-4 Element <i>Selects whether the 51G-4 IDMTL measured Earth Fault element is enabled</i>	Disabled, Enabled	Disabled	
Gn 51G-4 Dir. Control <i>Selects whether 51G-4 element is non-directional, forward or reverse</i>	Non-Dir, Forward, Reverse	Non-Dir	
Gn 51G-4 Setting <i>Pickup level</i>	0.005, 0.006 ... 0.995, 1	0.5xIn	
Gn 51G-4 Char <i>Selects characteristic curve to be IEC or ANSI IDMTL or DTL</i>	DTL, IEC-NI ... 201, 202	IEC-NI	
Gn 51G-4 Time Mult (IEC/ANSI) <i>Time multiplier (applicable to IEC and ANSI curves but not DTL selection)</i>	0.025, 0.05 ... 1.575, 1.6	1	
Gn 51G-4 Delay (DTL) <i>Delay (applicable only when DTL is selected for characteristic)</i>	0, 0.01 ... 19.99, 20	5s	
Gn 51G-4 Min Operate Time <i>Minimum operate time of element.</i>	0, 0.01 ... 19.99, 20	0s	
Gn 51G-4 Follower DTL <i>Additional definite time added after characteristic time</i>	0, 0.01 ... 19.99, 20	0s	
Gn 51G-4 Reset <i>Selects between an ANSI decaying reset characteristic or DTL reset</i>	(ANSI) Decaying, 0 ... 59, 60	0s	
Gn 51G-4 VTS Action <i>Selects whether 51G-4 element is blocked or made non-directional when VTS operates</i>	Off, Inhibit, Non-Dir	Off	
Gn 51G-4 Inrush Action <i>Selects if the 51G-4 element is blocked from operating when 2nd Harmonic Inrush Detector operates</i>	Off, Inhibit	Off	

3.4.4.5. 50G-1

Description	Range	Default	Setting
Gn 50G-1 Element <i>Selects whether the DTL measured Earth fault element is enabled</i>	Disabled, Enabled	Disabled	
Gn 50G-1 Dir. Control <i>Selects whether 50G-1 element is non-directional, forward or reverse</i>	Non-Dir, Forward, Reverse	Non-Dir	
Gn 50G-1 Setting <i>Pickup level</i>	0.005, 0.006 ... 24.95, 25	0.5xIn	
Gn 50G-1 Delay <i>Sets operate delay time</i>	0, 0.01 ... 14300, 14400	0s	
Gn 50G-1 VTS Action <i>Selects whether 50G-1 element is blocked or made non-directional when VTS operates</i>	Off, Inhibit, Non-Dir	Off	
Gn 50G-1 Inrush Action <i>Selects if the 50G-1 element is blocked from operating when 2nd Harmonic Inrush Detector operates</i>	Off, Inhibit	Off	

3.4.4.6. 50G-2

Description	Range	Default	Setting
Gn 50G-2 Element <i>Selects whether the DTL measured Earth fault element is enabled</i>	Disabled, Enabled	Disabled	
Gn 50G-2 Dir. Control <i>Selects whether 50G-2 element is non-directional, forward or reverse</i>	Non-Dir, Forward, Reverse	Non-Dir	
Gn 50G-2 Setting <i>Pickup level</i>	0.005, 0.006 ... 24.95, 25	0.5xIn	
Gn 50G-2 Delay <i>Sets operate delay time</i>	0, 0.01 ... 14300, 14400	0s	
Gn 50G-2 VTS Action <i>Selects whether 50G-2 element is blocked or made non-directional when VTS operates</i>	Off, Inhibit, Non-Dir	Off	
Gn 50G-2 Inrush Action <i>Selects if the 50G-2 element is blocked from operating when 2nd Harmonic Inrush Detector operates</i>	Off, Inhibit	Off	

3.4.4.7. 50G-3

Description	Range	Default	Setting
Gn 50G-3 Element <i>Selects whether the DTL measured Earth fault element is enabled</i>	Disabled, Enabled	Disabled	
Gn 50G-3 Dir. Control <i>Selects whether 50G-3 element is non-directional, forward or reverse</i>	Non-Dir, Forward, Reverse	Non-Dir	
Gn 50G-3 Setting <i>Pickup level</i>	0.005, 0.006 ... 24.95, 25	0.5xIn	
Gn 50G-3 Delay <i>Sets operate delay time</i>	0, 0.01 ... 14300, 14400	0s	

Description	Range	Default	Setting
Gn 50G-3 VTS Action <i>Selects whether 50G-3 element is blocked or made non-directional when VTS operates</i>	Off, Inhibit, Non-Dir	Off	
Gn 50G-3 Inrush Action <i>Selects if the 50G-3 element is blocked from operating when 2nd Harmonic Inrush Detector operates</i>	Off, Inhibit	Off	

3.4.4.8. 50G-4

Description	Range	Default	Setting
Gn 50G-4 Element <i>Selects whether the DTL measured Earth fault element is enabled</i>	Disabled, Enabled	Disabled	
Gn 50G-4 Dir. Control <i>Selects whether 50G-4 element is non-directional, forward or reverse</i>	Non-Dir, Forward, Reverse	Non-Dir	
Gn 50G-4 Setting <i>Pickup level</i>	0.005, 0.006 ... 24.95, 25	0.5xIn	
Gn 50G-4 Delay <i>Sets operate delay time</i>	0, 0.01 ... 14300, 14400	0s	
Gn 50G-4 VTS Action <i>Selects whether 50G-4 element is blocked or made non-directional when VTS operates</i>	Off, Inhibit, Non-Dir	Off	
Gn 50G-4 Inrush Action <i>Selects if the 50G-4 element is blocked from operating when 2nd Harmonic Inrush Detector operates</i>	Off, Inhibit	Off	

3.4.5. Sensitive E/F

Description	Range	Default	Setting
Gn 67SEF Char Angle <i>Maximum torque angle for sensitive earth fault elements</i>	-95, -94 ... 94, 95	-15deg	
Gn 67SEF Minimum Voltage <i>Selects the directional elements minimum voltage, below which the element will be inhibited</i>	0.33, 0.5 ... 66.5, 67	0.33V	
Gn 67SEF Compensated Network <i>When Enabled the directional elements boundaries are widened to +- 87.5 Degs</i>	Disabled, Enabled	Disabled	

3.4.5.1. 51SEF-1

Description	Range	Default	Setting
Gn 51SEF-1 Element <i>Selects whether the 51SEF-1 IDMTL Sensitive Earth Fault element is enabled</i>	Disabled, Enabled	Disabled	
Gn 51SEF-1 Dir. Control <i>Selects whether 51SEF-1 element is non-directional, forward or reverse</i>	Non-Dir, Forward, Reverse	Non-Dir	
Gn 51SEF-1 Setting <i>Pickup level</i>	0.005, 0.006 ... 0.995, 1	0.2xIn	
Gn 51SEF-1 Char <i>Selects characteristic curve to be IEC or ANSI IDMTL or DTL</i>	DTL, IEC-NI ... 201, 202	IEC-NI	
Gn 51SEF-1 Time Mult (IEC/ANSI) <i>Time multiplier (applicable to IEC and ANSI curves but not DTL selection)</i>	0.025, 0.05 ... 1.575, 1.6	1	
Gn 51SEF-1 Delay (DTL) <i>Delay (applicable only when DTL is selected for characteristic)</i>	0, 0.01 ... 19.99, 20	5s	
Gn 51SEF-1 Min Operate Time <i>Minimum operate time of element.</i>	0, 0.01 ... 19.99, 20	0s	
Gn 51SEF-1 Follower DTL <i>Additional definite time added after characteristic time</i>	0, 0.01 ... 19.99, 20	0s	
Gn 51SEF-1 Reset <i>Selects between an ANSI decaying reset characteristic or DTL reset</i>	(ANSI) Decaying, 0 ... 59, 60	0s	
Gn 51SEF-1 VTS Action <i>Selects whether 51SEF-1 element is blocked or made non-directional when VTS operates</i>	Off, Inhibit, Non-Dir	Off	

3.4.5.2. 51SEF-2

Description	Range	Default	Setting
Gn 51SEF-2 Element <i>Selects whether the 51SEF-2 IDMTL derived Earth Fault element is enabled</i>	Disabled, Enabled	Disabled	
Gn 51SEF-2 Dir. Control <i>Selects whether 51SEF-2 element is non-directional, forward or reverse</i>	Non-Dir, Forward, Reverse	Non-Dir	

Description	Range	Default	Setting
Gn 51SEF-2 Setting <i>Pickup level</i>	0.005, 0.006 ... 0.995, 1	0.2xIn	
Gn 51SEF-2 Char <i>Selects characteristic curve to be IEC or ANSI IDMTL or DTL</i>	DTL, IEC-NI ... 201, 202	IEC-NI	
Gn 51SEF-2 Time Mult (IEC/ANSI) <i>Time multiplier (applicable to IEC and ANSI curves but not DTL selection)</i>	0.025, 0.05 ... 1.575, 1.6	1	
Gn 51SEF-2 Delay (DTL) <i>Delay (applicable only when DTL is selected for characteristic)</i>	0, 0.01 ... 19.99, 20	5s	
Gn 51SEF-2 Min Operate Time <i>Minimum operate time of element.</i>	0, 0.01 ... 19.99, 20	0s	
Gn 51SEF-2 Follower DTL <i>Additional definite time added after characteristic time</i>	0, 0.01 ... 19.99, 20	0s	
Gn 51SEF-2 Reset <i>Selects between an ANSI decaying reset characteristic or DTL reset</i>	(ANSI) Decaying, 0 ... 59, 60	0s	
Gn 51SEF-2 VTS Action <i>Selects whether 51SEF-2 element is blocked or made non-directional when VTS operates</i>	Off, Inhibit, Non-Dir	Off	

3.4.5.3. 51SEF-3

Description	Range	Default	Setting
Gn 51SEF-3 Element <i>Selects whether the 51SEF-3 IDMTL derived Earth Fault element is enabled</i>	Disabled, Enabled	Disabled	
Gn 51SEF-3 Dir. Control <i>Selects whether 51SEF-3 element is non-directional, forward or reverse</i>	Non-Dir, Forward, Reverse	Non-Dir	
Gn 51SEF-3 Setting <i>Pickup level</i>	0.005, 0.006 ... 0.995, 1	0.2xIn	
Gn 51SEF-3 Char <i>Selects characteristic curve to be IEC or ANSI IDMTL or DTL</i>	DTL, IEC-NI ... 201, 202	IEC-NI	
Gn 51SEF-3 Time Mult (IEC/ANSI) <i>Time multiplier (applicable to IEC and ANSI curves but not DTL selection)</i>	0.025, 0.05 ... 1.575, 1.6	1	
Gn 51SEF-3 Delay (DTL) <i>Delay (applicable only when DTL is selected for characteristic)</i>	0, 0.01 ... 19.99, 20	5s	
Gn 51SEF-3 Min Operate Time <i>Minimum operate time of element.</i>	0, 0.01 ... 19.99, 20	0s	
Gn 51SEF-3 Follower DTL <i>Additional definite time added after characteristic time</i>	0, 0.01 ... 19.99, 20	0s	
Gn 51SEF-3 Reset <i>Selects between an ANSI decaying reset characteristic or a definite time reset</i>	(ANSI) Decaying, 0 ... 59, 60	0s	

Description	Range	Default	Setting
Gn 51SEF-3 VTS Action <i>Selects whether 51SEF-3 element is blocked or made non-directional when VTS operates</i>	Off, Inhibit, Non-Dir	Off	

3.4.5.4. 51SEF-4

Description	Range	Default	Setting
Gn 51SEF-4 Element <i>Selects whether the 51SEF-4 IDMTL derived Earth Fault element is enabled</i>	Disabled, Enabled	Disabled	
Gn 51SEF-4 Dir. Control <i>Selects whether 51SEF-4 element is non-directional, forward or reverse</i>	Non-Dir, Forward, Reverse	Non-Dir	
Gn 51SEF-4 Setting <i>Pickup level</i>	0.005, 0.006 ... 0.995, 1	0.2xIn	
Gn 51SEF-4 Char <i>Selects characteristic curve to be IEC or ANSI IDMTL or DTL</i>	DTL, IEC-NI ... 201, 202	IEC-NI	
Gn 51SEF-4 Time Mult (IEC/ANSI) <i>Time multiplier (applicable to IEC and ANSI curves but not DTL selection)</i>	0.025, 0.05 ... 1.575, 1.6	1	
Gn 51SEF-4 Delay (DTL) <i>Delay (applicable only when DTL is selected for characteristic)</i>	0, 0.01 ... 19.99, 20	5s	
Gn 51SEF-4 Min Operate Time <i>Minimum operate time of element.</i>	0, 0.01 ... 19.99, 20	0s	
Gn 51SEF-4 Follower DTL <i>Additional definite time added after characteristic time</i>	0, 0.01 ... 19.99, 20	0s	
Gn 51SEF-4 Reset <i>Selects between an ANSI decaying reset characteristic or a definite time reset</i>	(ANSI) Decaying, 0 ... 59, 60	0s	
Gn 51SEF-4 VTS Action <i>Selects whether 51SEF-4 element is blocked or made non-directional when VTS operates</i>	Off, Inhibit, Non-Dir	Off	

3.4.5.5. 50SEF-1

Description	Range	Default	Setting
Gn 50SEF-1 Element <i>Selects whether the DTL measured Earth fault element is enabled</i>	Disabled, Enabled	Disabled	
Gn 50SEF-1 Dir. Control <i>Selects whether 50SEF-1 element is non-directional, forward or reverse</i>	Non-Dir, Forward, Reverse	Non-Dir	
Gn 50SEF-1 Setting <i>Pickup level</i>	0.005, 0.006 ... 4.995, 5	0.2xIn	
Gn 50SEF-1 Delay <i>Sets operate delay time</i>	0, 0.01 ... 14300, 14400	0s	
Gn 50SEF-1 VTS Action <i>Selects whether 50SEF-1 element is blocked or made non-directional when VTS operates</i>	Off, Inhibit, Non-Dir	Off	

3.4.5.6. 50SEF-2

Description	Range	Default	Setting
Gn 50SEF-2 Element <i>Selects whether the DTL measured Earth fault element is enabled</i>	Disabled, Enabled	Disabled	
Gn 50SEF-2 Dir. Control <i>Selects whether 50SEF-2 element is non-directional, forward or reverse</i>	Non-Dir, Forward, Reverse	Non-Dir	
Gn 50SEF-2 Setting <i>Pickup level</i>	0.005, 0.006 ... 4.995, 5	0.2xIn	
Gn 50SEF-2 Delay <i>Sets operate delay time</i>	0, 0.01 ... 14300, 14400	0s	
Gn 50SEF-2 VTS Action <i>Selects whether 50SEF-2 element is blocked or made non-directional when VTS operates</i>	Off, Inhibit, Non-Dir	Off	

3.4.5.7. 50SEF-3

Description	Range	Default	Setting
Gn 50SEF-3 Element <i>Selects whether the DTL measured Earth fault element is enabled</i>	Disabled, Enabled	Disabled	
Gn 50SEF-3 Dir. Control <i>Selects whether 50SEF-3 element is non-directional, forward or reverse</i>	Non-Dir, Forward, Reverse	Non-Dir	
Gn 50SEF-3 Setting <i>Pickup level</i>	0.005, 0.006 ... 4.995, 5	0.2xIn	
Gn 50SEF-3 Delay <i>Sets operate delay time</i>	0, 0.01 ... 14300, 14400	0s	
Gn 50SEF-3 VTS Action <i>Selects whether 50SEF-3 element is blocked or made non-directional when VTS operates</i>	Off, Inhibit, Non-Dir	Off	

3.4.5.8. 50SEF-4

Description	Range	Default	Setting
Gn 50SEF-4 Element <i>Selects whether the DTL measured Earth fault element is enabled</i>	Disabled, Enabled	Disabled	
Gn 50SEF-4 Dir. Control <i>Selects whether 50SEF-4 element is non-directional, forward or reverse</i>	Non-Dir, Forward, Reverse	Non-Dir	
Gn 50SEF-4 Setting <i>Pickup level</i>	0.005, 0.006 ... 4.995, 5	0.2xIn	
Gn 50SEF-4 Delay <i>Sets operate delay time</i>	0, 0.01 ... 14300, 14400	0s	
Gn 50SEF-4 VTS Action <i>Selects whether 50SEF-4 element is blocked or made non-directional when VTS operates</i>	Off, Inhibit, Non-Dir	Off	

3.4.6. Restricted E/F

Description	Range	Default	Setting
Gn 64H Element <i>High impedance restricted earth fault current element</i>	Disabled, Enabled	Disabled	
Gn 64H Setting <i>Pickup level</i>	0.005, 0.006 ... 0.945, 0.95	0.2xIn	
Gn 64H Delay <i>Sets operate delay time</i>	0, 0.01 ... 14300, 14400	0s	

3.4.7. NPS Overcurrent

3.4.7.1. 46IT

Description	Range	Default	Setting
Gn 46IT Element <i>Selects whether the 46IT IDMTL/DTL negative phase sequence current element is enabled</i>	Disabled, Enabled	Disabled	
Gn 46IT Setting <i>Pickup level</i>	0.05, 0.06 ... 2.49, 2.5	0.25xIn	
Gn 46IT Char <i>Selects characteristic curve to be IEC or ANSI IDMTL or DTL</i>	DTL, IEC-NI, IEC-VI, IEC-EI, IEC-LTI, ANSI-MI, ANSI-VI, ANSI-EI	IEC-NI	
Gn 46IT Time Mult (IEC/ANSI) <i>Time multiplier (applicable to IEC and ANSI curves but not DTL selection)</i>	0.025, 0.05 ... 1.575, 1.6	1	
Gn 46IT Delay (DTL) <i>Delay (applicable only when DTL is selected for characteristic)</i>	0, 0.01 ... 19.99, 20	5s	
Gn 46IT Reset <i>Selects between an ANSI decaying reset characteristic or a definite time reset</i>	(ANSI) Decaying, 0 ... 59, 60	0s	

3.4.7.2. 46DT

Description	Range	Default	Setting
Gn 46DT Element <i>Selects whether the 46DT INST/DTL negative sequence current element is enabled</i>	Disabled, Enabled	Disabled	
Gn 46DT Setting <i>Pickup level</i>	0.05, 0.06 ... 3.99, 4	0.1xIn	
Gn 46DT Delay <i>Sets operate delay time</i>	0, 0.01 ... 14300, 14400	0.02s	

3.4.8. Under Current

3.4.8.1. 37-1

Description	Range	Default	Setting
Gn 37-1 Element <i>Phase under current element 37-1</i>	Disabled, Enabled	Disabled	
Gn 37-1 Setting <i>Pickup level</i>	0.05, 0.1 ... 4.95, 5	0.25xIn	
Gn 37-1 Delay <i>Sets operate delay time</i>	0, 0.01 ... 14300, 14400	0s	

3.4.8.2. 37-2

Description	Range	Default	Setting
Gn 37-2 Element <i>Phase under current element 37-2</i>	Disabled, Enabled	Disabled	
Gn 37-2 Setting <i>Pickup level</i>	0.05, 0.1 ... 4.95, 5	0.25xIn	
Gn 37-2 Delay <i>Sets operate delay time</i>	0, 0.01 ... 14300, 14400	0s	

3.4.9. Thermal

Description	Range	Default	Setting
Gn 49 Thermal Overload <i>Selects whether the thermal overload protection element is enabled</i>	Disabled, Enabled	Disabled	
Gn 49 Overload Setting <i>Pickup level</i>	0.1, 0.11 ... 2.99, 3	1.05xIn	
Gn 49 Time Constant <i>Thermal time constant</i>	1, 1.5 ... 999.5, 1000	10m	
Gn 49 Capacity Alarm <i>Selects whether thermal capacity alarm enabled</i>	Disabled, 50 ... 99, 100	Disabled	
49 Reset Therm State <i>Control that allows thermal state to be manually reset</i>			

3.5. Voltage Prot'n

3.5.1. Phase U/O voltage

Description	Range	Default	Setting
Gn Voltage Input Mode <i>Selects Ph-Ph or Ph-N voltages for U/V guard element & 27/59 elements operation.</i>	Ph-N, Ph-Ph	Ph-N	
Gn 27/59 U/V Guard Setting <i>Selects voltage level below which the guard element is applied.</i>	1, 1.5 ... 199.5, 200	5V	

3.5.1.1. 27/59-1

Description	Range	Default	Setting
Gn 27/59-1 Element <i>Selects whether the Under/Over voltage element stage 1 is enabled</i>	Disabled, Enabled	Disabled	
Gn 27/59-1 Operation <i>Selects between Undervoltage and Overvoltage pickup for this element</i>	Under, Over	Over	
Gn 27/59-1 Setting <i>Under or over voltage pickup level</i>	5, 5.5 ... 199.5, 200	80V	
Gn 27/59-1 Hysteresis <i>Sets the pickup to dropoff thresholds e.g. 3% on Overlevel picks up above pickup setting and drops off below 97% of setting, 3% on Underlevel picks up below setting and drops off above 103% of setting</i>	0, 0.1 ... 79.9, 80	3%	
Gn 27/59-1 Delay <i>Sets operate delay time</i>	0, 0.01 ... 14300, 14400	0.1s	
Gn 27/59-1 U/V Guarded <i>Selects whether U/V Guard element can block the operation of this element</i>	No, Yes	No	
Gn 27/59-1 VTS Inhibit <i>Selects whether element is blocked or not when VTS operates</i>	No, Yes	No	
Gn 27/59-1 O/P Phases <i>Selects whether element operates for any phase picked up or only when all phases are picked up</i>	Any, All	Any	

3.5.1.2. 27/59-2

Description	Range	Default	Setting
Gn 27/59-2 Element <i>Selects whether the Under/Over voltage element stage 2 is enabled</i>	Disabled, Enabled	Disabled	
Gn 27/59-2 Operation <i>Selects between Undervoltage and Overvoltage pickup for this element</i>	Under, Over	Over	
Gn 27/59-2 Setting <i>Under or over voltage pickup level</i>	5, 5.5 ... 199.5, 200	80V	
Gn 27/59-2 Hysteresis <i>Sets the pickup to dropoff thresholds e.g. 3% on Overlevel picks up above pickup setting and drops off below 97% of setting, 3% on Underlevel picks up below setting and drops off above 103% of setting</i>	0, 0.1 ... 79.9, 80	3%	
Gn 27/59-2 Delay <i>Sets operate delay time</i>	0, 0.01 ... 14300, 14400	0.1s	
Gn 27/59-2 U/V Guarded <i>Selects whether U/V Guard element can block the operation of this element</i>	No, Yes	No	
Gn 27/59-2 VTS Inhibit <i>Selects whether element is blocked or not when VTS operates</i>	No, Yes	No	

Description	Range	Default	Setting
Gn 27/59-2 O/P Phases <i>Selects whether element operates for any phase picked up or only when all phases are picked up</i>	Any, All	Any	

3.5.1.3. 27/59-3

Description	Range	Default	Setting
Gn 27/59-3 Element <i>Selects whether the Under/Over voltage element stage 3 is enabled</i>	Disabled, Enabled	Disabled	
Gn 27/59-3 Operation <i>Selects between Undervoltage and Overvoltage pickup for this element</i>	Under, Over	Under	
Gn 27/59-3 Setting <i>Under or over voltage pickup level</i>	5, 5.5 ... 199.5, 200	50V	
Gn 27/59-3 Hysteresis <i>Sets the pickup to dropoff thresholds e.g. 3% on Overlevel picks up above pickup setting and drops off below 97% of setting, 3% on Underlevel picks up below setting and drops off above 103% of setting</i>	0, 0.1 ... 79.9, 80	3%	
Gn 27/59-3 Delay <i>Sets operate delay time</i>	0, 0.01 ... 14300, 14400	0.1s	
Gn 27/59-3 U/V Guarded <i>Selects whether U/V Guard element can block the operation of this element</i>	No, Yes	Yes	
Gn 27/59-3 VTS Inhibit <i>Selects whether element is blocked or not when VTS operates</i>	No, Yes	No	
Gn 27/59-3 O/P Phases <i>Selects whether element operates for any phase picked up or only when all phases are picked up</i>	Any, All	Any	

3.5.1.4. 27/59-4

Description	Range	Default	Setting
Gn 27/59-4 Element <i>Selects whether the Under/Over voltage element stage 4 is enabled</i>	Disabled, Enabled	Disabled	
Gn 27/59-4 Operation <i>Selects between Undervoltage and Overvoltage pickup for this element</i>	Under, Over	Under	
Gn 27/59-4 Setting <i>Under or over voltage pickup level</i>	5, 5.5 ... 199.5, 200	50V	
Gn 27/59-4 Hysteresis <i>Sets the pickup to dropoff thresholds e.g. 3% on Overlevel picks up above pickup setting and drops off below 97% of setting, 3% on Underlevel picks up below setting and drops off above 103% of setting</i>	0, 0.1 ... 79.9, 80	3%	
Gn 27/59-4 Delay <i>Sets operate delay time</i>	0, 0.01 ... 14300, 14400	0.1s	

Description	Range	Default	Setting
Gn 27/59-4 U/V Guarded <i>Selects whether U/V Guard element can block the operation of this element</i>	No, Yes	Yes	
Gn 27/59-4 VTS Inhibit <i>Selects whether element is blocked or not when VTS operates</i>	No, Yes	No	
Gn 27/59-4 O/P Phases <i>Selects whether element operates for any phase picked up or only when all phases are picked up</i>	Any, All	Any	

3.5.2. Vx U/O voltage

Description	Range	Default	Setting
Gn Vx 27/59 Element <i>Selects whether the Under/Over voltage element for Vx is enabled</i>	Disabled, Enabled	Disabled	
Gn Vx 27/59 Operation <i>Selects between Undervoltage and Overvoltage pickup for this element</i>	Under, Over	Over	
Gn Vx 27/59 Setting <i>Under or over voltage pickup level</i>	5, 5.5 ... 199.5, 200	80V	
Gn Vx 27/59 Hysteresis <i>Sets the pickup to dropoff thresholds e.g. 3% on Overlevel picks up above pickup setting and drops off below 97% of setting, 3% on Underlevel picks up below setting and drops off above 103% of setting</i>	0, 0.1 ... 79.9, 80	3%	
Gn Vx 27/59 Delay <i>Sets operate delay time</i>	0, 0.01 ... 14300, 14400	0.1s	

3.5.3. NPS overvoltage

3.5.3.1. 47-1

Description	Range	Default	Setting
Gn 47-1 Element <i>Selects whether the definite time NPS overvoltage element is enabled</i>	Disabled, Enabled	Disabled	
Gn 47-1 Setting <i>Pickup level</i>	1, 1.5 ... 89.5, 90	20V	
Gn 47-1 Hysteresis <i>Sets the pickup to drop-off thresholds e.g. 3% picks up at setting and drops off below 97% of setting</i>	0, 0.1 ... 79.9, 80	3%	
Gn 47-1 Delay <i>Sets operate delay time</i>	0, 0.01 ... 14300, 14400	1s	

3.5.3.2. 47-2

Description	Range	Default	Setting
Gn 47-2 Element <i>Selects whether the definite time NPS overvoltage element is enabled</i>	Disabled, Enabled	Disabled	

Description	Range	Default	Setting
Gn 47-2 Setting <i>Pickup level</i>	1, 1.5 ... 89.5, 90	20V	
Gn 47-2 Hysteresis <i>Sets the pickup to drop-off thresholds e.g. 3% picks up at setting and drops off below 97% of setting</i>	0, 0.1 ... 79.9, 80	3%	
Gn 47-2 Delay <i>Sets operate delay time</i>	0, 0.01 ... 14300, 14400	0.5s	

3.5.4. Neutral overvoltage

Description	Range	Default	Setting
Gn 59N Voltage Source <i>Selects voltage source between calculated 3V0 (Vn) or measured 3V0 through Vx input</i>	Vn, Vx	Vn	

3.5.4.1. 59NIT

Description	Range	Default	Setting
Gn 59NIT Element <i>Selects whether the inverse time neutral over voltage element is enabled</i>	Disabled, Enabled	Disabled	
Gn 59NIT Setting <i>Pickup level</i>	1, 1.5 ... 99.5, 100	5V	
Gn 59NIT Char <i>Selects characteristic curve to be IDMTL or DTL</i>	DTL, IDMTL	IDMTL	
Gn 59NIT Time Mult (IDMTL) <i>Time multiplier (applicable to IDMTL curve but not DTL selection)</i>	0.1, 0.2 ... 139.5, 140	1	
Gn 59NIT Delay (DTL) <i>Delay (applicable only when DTL is selected for characteristic)</i>	0, 0.01 ... 19.99, 20	5s	
Gn 59NIT Reset <i>Selects between an instantaneous reset characteristic or a definite time reset</i>	(ANSI) Decaying, 0 ... 59, 60	0s	

3.5.4.2. 59NDT

Description	Range	Default	Setting
Gn 59NDT Element <i>Selects whether the definite time neutral over voltage element is enabled</i>	Disabled, Enabled	Disabled	
Gn 59NDT Setting <i>Pickup level</i>	1, 1.5 ... 99.5, 100	5V	
Gn 59NDT Delay <i>Sets operate delay time</i>	0, 0.01 ... 14300, 14400	0.01s	

3.5.5. U/O Frequency

Description	Range	Default	Setting
Gn 81 U/V Guard Setting <i>Selects voltage level below which the guard element is applied.</i>	5, 5.5 ... 199.5, 200	5V	

3.5.5.1. 81-1

Description	Range	Default	Setting
Gn 81-1 Element <i>Selects whether the Under/Over frequency element stage 1 is enabled</i>	Disabled, Enabled	Disabled	
Gn 81-1 Operation <i>Selects between Underfrequency and Overfrequency pickup for this element</i>	Under, Over	Under	
Gn 81-1 Setting <i>Under or over frequency pickup level</i>	40, 40.01 ... 69.98, 69.99	49.5Hz	
Gn 81-1 Hysteresis <i>Sets the pickup to dropoff thresholds e.g. 3% on Overlevel picks up above pickup setting and drops off below 97% of setting, 3% on Underlevel picks up below setting and drops off above 103% of setting</i>	0, 0.1 ... 79.9, 80	0.1%	
Gn 81-1 Delay <i>Sets operate delay time</i>	0, 0.01 ... 14300, 14400	1s	
Gn 81-1 U/V Guarded <i>Selects whether U/V Guard element can block the operation of this element</i>	No, Yes	Yes	

3.5.5.2. 81-2

Description	Range	Default	Setting
Gn 81-2 Element <i>Selects whether the Under/Over frequency element stage 2 is enabled</i>	Disabled, Enabled	Disabled	
Gn 81-2 Operation <i>Selects between Underfrequency and Overfrequency pickup for this element</i>	Under, Over	Under	
Gn 81-2 Setting <i>Under or over frequency pickup level</i>	40, 40.01 ... 69.98, 69.99	49Hz	

Description	Range	Default	Setting
Gn 81-2 Hysteresis <i>Sets the pickup to dropoff thresholds e.g. 3% on Overlevel picks up above pickup setting and drops off below 97% of setting, 3% on Underlevel picks up below setting and drops off above 103% of setting</i>	0, 0.1 ... 79.9, 80	0.1%	
Gn 81-2 Delay <i>Sets operate delay time</i>	0, 0.01 ... 14300, 14400	0.8s	
Gn 81-2 U/V Guarded <i>Selects whether U/V Guard element can block the operation of this element</i>	No, Yes	Yes	

3.5.5.3. 81-3

Description	Range	Default	Setting
Gn 81-3 Element <i>Selects whether the Under/Over frequency element stage 3 is enabled</i>	Disabled, Enabled	Disabled	
Gn 81-3 Operation <i>Selects between Underfrequency and Overfrequency pickup for this element</i>	Under, Over	Under	
Gn 81-3 Setting <i>Under or over frequency pickup level</i>	40, 40.01 ... 69.98, 69.99	48Hz	
Gn 81-3 Hysteresis <i>Sets the pickup to dropoff thresholds e.g. 3% on Overlevel picks up above pickup setting and drops off below 97% of setting, 3% on Underlevel picks up below setting and drops off above 103% of setting</i>	0, 0.1 ... 79.9, 80	0.1%	
Gn 81-3 Delay <i>Sets operate delay time</i>	0, 0.01 ... 14300, 14400	0.6s	
Gn 81-3 U/V Guarded <i>Selects whether U/V Guard element can block the operation of this element</i>	No, Yes	Yes	

3.5.5.4. 81-4

Description	Range	Default	Setting
Gn 81-4 Element <i>Selects whether the Under/Over frequency element stage 4 is enabled</i>	Disabled, Enabled	Disabled	
Gn 81-4 Operation <i>Selects between Underfrequency and Overfrequency pickup for this element</i>	Under, Over	Under	
Gn 81-4 Setting <i>Under or over frequency pickup level</i>	40, 40.01 ... 69.98, 69.99	47.5Hz	
Gn 81-4 Hysteresis <i>Sets the pickup to dropoff thresholds e.g. 3% on Overlevel picks up above pickup setting and drops off below 97% of setting, 3% on Underlevel picks up below setting and drops off above 103% of setting</i>	0, 0.1 ... 79.9, 80	0.1%	
Gn 81-4 Delay <i>Sets operate delay time</i>	0, 0.01 ... 14300, 14400	0.4s	

Description	Range	Default	Setting
Gn 81-4 U/V Guarded <i>Selects whether U/V Guard element can block the operation of this element</i>	No, Yes	Yes	

3.6. Supervision

3.6.1. CB Fail

Description	Range	Default	Setting
Gn 50BF Element <i>Selects whether the Circuit Breaker Fail element is enabled</i>	Disabled, Enabled	Disabled	
Gn 50BF Setting <i>Breaker Fail Current Pickup level. If the current falls below this level then the CB is deemed to have opened and the element is reset.</i>	0.05, 0.055 ... 1.995, 2	0.2xIn	
Gn 50BF-I4 Setting	0.005, 0.01 ... 1.995, 2	0.05xIn	
Gn 50BF-1 Delay <i>Delay before Circuit Breaker Fail stage 1 operates</i>	20, 25 ... 59995, 60000	60ms	
Gn 50BF-2 Delay <i>Delay before Circuit Breaker Fail stage 2 operates</i>	20, 25 ... 59995, 60000	120ms	

3.6.2. VT supervision

Description	Range	Default	Setting
Gn 60VTS Element <i>Selects whether the VT supervision element is enabled</i>	Disabled, Enabled	Disabled	
Gn 60VTS Component <i>Selects whether NPS or ZPS quantities are used by the VT supervision element</i>	NPS, ZPS	NPS	
Gn 60VTS V <i>Level above which there is a possible 1 or 2 phase VT fuse failure</i>	7, 8 ... 109, 110	7V	
Gn 60VTS I <i>Level above which a 1 or 2 phase fault condition is assumed so VTS inhibited</i>	0.05, 0.1, 0.15, 0.2, 0.25, 0.3, 0.35, 0.4, 0.45, 0.5, 0.55, 0.6, 0.65, 0.7, 0.75, 0.8, 0.85, 0.9, 0.95, 1	0.1xIn	
Gn 60VTS Vpps <i>Level below which there is a possible 3 phase VT fuse failure</i>	1, 2 ... 109, 110	15V	
Gn 60VTS Ipps Load <i>Level current must be above before 3 phase VTS will be issued</i>	0.05, 0.1, 0.15, 0.2, 0.25, 0.3, 0.35, 0.4, 0.45, 0.5, 0.55, 0.6, 0.65, 0.7, 0.75, 0.8, 0.85, 0.9, 0.95, 1	0.1xIn	
Gn 60VTS Ipps Fault <i>Level above which 3 phase fault is assumed so VTS inhibited</i>	0.05, 0.1 ... 19.95, 20	10xIn	

Description	Range	Default	Setting
Gn 60VTS Delay <i>Sets operate delay time</i>	0.03, 0.04 ... 14300, 14400	10s	
Gn 60VTF-Bus Element <i>Selects whether the Bus VT Fail element is enabled. Element based on voltages and circuit breaker position</i>	Enabled, Disabled	Disabled	
Gn 60VTF-Bus Delay <i>Sets operate delay time</i>	0, 0.1 ... 99.9, 100	2s	

3.6.3. CT supervision

Description	Range	Default	Setting
Gn 60CTS Element <i>Selects whether the CT supervision element is enabled (NPS current in the absence of NPS voltage)</i>	Disabled, Enabled	Disabled	
Gn 60CTS Inps <i>Arm if NPS Current (Inps) is above this level</i>	0.05, 0.1, 0.15, 0.2, 0.25, 0.3, 0.35, 0.4, 0.45, 0.5, 0.55, 0.6, 0.65, 0.7, 0.75, 0.8, 0.85, 0.9, 0.95, 1	0.1xIn	
Gn 60CTS Vnps <i>Inhibit if NPS Voltage (Vnps) is above this level</i>	7, 8 ... 109, 110	10V	
Gn 60CTS Delay <i>CTS Operate delay</i>	0.03, 0.04 ... 14300, 14400	10s	

3.6.4. Broken Conductor

Description	Range	Default	Setting
Gn 46BC Element <i>Selects whether the definite time broken conductor element is enabled</i>	Disabled, Enabled	Disabled	
Gn 46BC Setting <i>NPS Current to PPS Current ratio</i>	20, 21 ... 99, 100	20%	
Gn 46BC Delay <i>Sets operate delay time</i>	0.03, 0.04 ... 14300, 14400	20s	

3.6.5. Trip CCT supervision

Description	Range	Default	Setting
Gn 74TCS-1 <i>Selects whether the trip circuit supervision element 74TCS-1 is enabled</i>	Disabled, Enabled	Disabled	
Gn 74TCS-1 Delay <i>Time delay before trip circuit supervision operates</i>	0, 0.02 ... 59.98, 60	0.4s	
Gn 74TCS-2 <i>Selects whether the trip circuit supervision element 74TCS-2 is enabled</i>	Disabled, Enabled	Disabled	
Gn 74TCS-2 Delay <i>Time delay before trip circuit supervision operates</i>	0, 0.02 ... 59.98, 60	0.4s	

Description	Range	Default	Setting
Gn 74TCS-3 <i>Selects whether the trip circuit supervision element 74TCS-3 is enabled</i>	Disabled, Enabled	Disabled	
Gn 74TCS-3 Delay <i>Time delay before trip circuit supervision operates</i>	0, 0.02 ... 59.98, 60	0.4s	

3.6.6. Inrush detector

Description	Range	Default	Setting
Gn 81HBL2 Element <i>Selects whether the phase inrush detector 81HBL2 is enabled</i>	Disabled, Enabled	Disabled	
Gn 81HBL2 Bias <i>Selects the bias method used for magnetising inrush. Phase – Segregated, each phase blocks itself. Cross – Blocked, each phase can block the operation of other phases. Sum - Of Squares, each phase blocks itself using the square root of the sum of squares of the 2nd harmonic.</i>	Phase, Cross, Sum	Cross	
Gn 81HBL2 Setting <i>The magnetising inrush detector operates when the 2nd harmonic current exceeds a set percentage of the fundamental current</i>	0.1, 0.11 ... 0.49, 0.5	0.2xl	

3.6.7. Battery Test

Description	Range	Default	Setting
Battery Element <i>Selects whether the Battery Element is enabled</i>	Disabled, Enabled	Disabled	
Battery Nominal Voltage <i>Selects battery nominal voltage</i>	24, 30, 48, 110, 220	48V	
Battery Test Rate <i>Frequency of battery tests</i>	Every 12 Hours, Every Day ... Every Nov 1st, Every Dec 1st	Every Month 1st	
Battery Test Time <i>Hour of the day at which test will take place</i>	0, 1 ... 22, 23	12	
Battery Test Load <i>Load resistance applied during test</i>	2.5, 2.6 ... 99.9, 100	6.8ohms	
Battery Volts Drop <i>Max step change in voltage allowed when test load is applied</i>	0.5, 0.75, 1, 1.25, 1.5, 1.75, 2, 2.25, 2.5, 2.75, 3, 3.25, 3.5	2.5V	

3.6.8. Capacitor Test

Description	Range	Default	Setting
Cap Element <i>Selects whether the Capacitor Element is enabled</i>	Disabled, Enabled	Disabled	
Cap Holdup Time <i>If capacitor test load applied for this time & capacitor is still above test threshold the load test will be classed as a pass</i>	0, 0.02 ... 9.9, 10	5s	

3.6.9. Power Quality

Description	Range	Default	Setting
Gn Voltage Input Mode <i>Selects Ph-Ph or Ph-N voltages for U/V guard element & 27/59 elements operation.</i>	Ph-N, Ph-Ph	Ph-N	

3.6.10. 27SAG

Description	Range	Default	Setting
Gn 27Sag Element <i>Selects whether the 27Sag Element is enabled</i>	Disabled, Enabled	Disabled	
Gn 27Sag SARFI Threshold <i>Percentage of nominal voltage below which 27Sag SARFI is raised</i>	10, 20, 30, 40, 50, 60, 70, 80, 90	70%	
Gn 27Sag VTS Block <i>Selects whether element is blocked or not when VTS operates</i>	Disabled, Enabled	Disabled	
Gn 27Sag SIARFI Delay <i>Time below which the SIARFI count is incremented</i>	0, 0.01 ... 55, 60	0.5s	
Gn 27Sag SMARFI Delay <i>Time below which the SMARFI count is incremented, if greater than SIARFI Delay.</i>	0, 0.01 ... 55, 60	5s	
Gn 27Sag STARFI Delay <i>Time below which the STARFI count is incremented, if greater than SMARFI Delay. If voltage dip longer than this time it is classed as an interruption.</i>	0, 0.01 ... 55, 60	60s	

3.6.11. 59SWELL

Description	Range	Default	Setting
Gn 59Swell Element <i>Selects whether the 59Swell Element is enabled</i>	Disabled, Enabled	Disabled	
Gn 59Swell SARFI Threshold <i>Percentage of nominal voltage above which 59 SARFI is raised.</i>	110, 120, 130, 140	120%	
Gn 59Swell SIARFI Delay <i>Time below which the SIARFI count is incremented.</i>	0, 0.01 ... 55, 60	0.5s	

Description	Range	Default	Setting
Gn 59Swell SMARFI Delay <i>Time below which the SMARFI count is incremented, if greater than SIARFI Delay</i>	0, 0.01 ... 55, 60	5s	
Gn 59Swell STARFI Delay <i>Time below which the STARFI count is incremented, if greater than SMARFI Delay.</i>	0, 0.01 ... 55, 60	60s	

3.7. Control & Logic

3.7.1. Autoreclose Prot'n

Description	Range	Default	Setting
Gn 79 P/F Inst Trips <i>Selects which phase fault protection elements are classed as Instantaneous elements and start an autoreclose sequence. These will be blocked from operating during Delayed autoreclose sequences. See autoreclose section of manual for detail of what elements can cause only Delayed protection to be used.</i>	Combination of (51-1, 51-2, 51-3, 51-4, 50-1, 50-2, 50-3, 50-4)	-----	
Gn 79 E/F Inst Trips <i>Selects which earth fault protection elements are classed as Instantaneous elements and start an autoreclose sequence. These will be blocked from operating during Delayed autoreclose sequences. See autoreclose section of manual for detail of what elements can cause only Delayed protection to be used.</i>	Combination of (51G-1, 51G-2, 51G-3, 51G-4, 50G-1, 50G-2, 50G-3, 50G-4)	-----	
Gn 79 SEF Inst Trips <i>Selects which sensitive earth fault protection elements are classed as Instantaneous elements and start an autoreclose sequence. These will be blocked from operating during Delayed autoreclose sequences. See autoreclose section of manual for detail of what elements can cause only Delayed protection to be used.</i>	Combination of (51SEF-1, 51SEF-2, 51SEF-3, 51SEF-4, 50SEF-1, 50SEF-2, 50SEF-3, 50SEF-4)	-----	
Gn 79 P/F Delayed Trips <i>Selects which phase fault protection are classed as Delayed elements, any selected elements operating will start an autoreclose sequence.</i>	Combination of (51-1, 51-2, 51-3, 51-4, 50-1, 50-2, 50-3, 50-4)	51-1, 51-2, 51-3, 51-4, 50-1, 50-2, 50-3, 50-4	
Gn 79 E/F Delayed Trips <i>Selects which earth fault protection are classed as Delayed elements, any selected elements operating will start an autoreclose sequence.</i>	Combination of (51G-1, 51G-2, 51G-3, 51G-4, 50G-1, 50G-2, 50G-3, 50G-4)	51G-1, 51G-2, 51G-3, 51G-4, 50G-1, 50G-2, 50G-3, 50G-4	
Gn 79 SEF Delayed Trips <i>Selects which sensitive earth fault elements are classed as Delayed elements, any selected elements operating will start an autoreclose sequence.</i>	Combination of (51SEF-1, 51SEF-2, 51SEF-3, 51SEF-4, 50SEF-1, 50SEF-2, 50SEF-3, 50SEF-4)	51SEF-1, 51SEF-2, 51SEF-3, 51SEF-4, 50SEF-1, 50SEF-2, 50SEF-3, 50SEF-4	

Description	Range	Default	Setting
Gn 79 P/F HS Trips <i>Selects which phase fault elements are classed as High Set elements, any selected elements operating will start an autoreclose sequence.</i>	Combination of (50-1, 50-2, 50-3, 50-4)	----	
Gn 79 E/F HS Trips <i>Selects which earth fault elements are classed as High Set elements, any selected elements operating will start an autoreclose sequence.</i>	Combination of (50G-1, 50G-2, 50G-3, 50G-4)	----	

3.7.2. Autoreclose Config

Description	Range	Default	Setting
Gn 79 Autoreclose <i>If disabled then all attempts to control the AR IN/OUT status will fail and the AR will be permanently Out Of Service. When enabled the AR IN/OUT state may be controlled via the CONTROL MODE menu option, via Binary Input or via local or remote communications.</i>	Disabled, Enabled	Disabled	
Gn 79 Num Shots <i>Selects the number of auto-reclose attempts before the Autorecloser locks out</i>	1, 2, 3, 4	1	
Gn 79 Retry Enable <i>Selects whether the Retry close functionality is enabled</i>	Disabled, Enabled	Disabled	
Gn 79 Retry Attempts <i>Selects the number of retries allowed per shot</i>	0, 1, 2, 3, 4, 5, 6, 7, 8, 9, 10	1	
Gn 79 Retry Interval <i>Time delay between retries</i>	0, 1 ... 599, 600	60s	
Gn 79 Reclose Blocked Delay <i>Specifies the maximum time that the Autorecloser can be blocked before proceeding to the lockout state. (NOTE: The block delay timer only starts after the Deadtime.)</i>	0, 1 ... 599, 600	60s	
Gn 79 Sequence Fail Timer <i>Time before lockout occurs on an incomplete reclose sequence. (i.e Trip & starter conditions have not been cleared after Sequence Fail Time.)</i>	0, 1 ... 599, 600	60s	
Gn 79 Minimum LO Delay <i>The time after entering lockout before any further external close commands are allowed.</i>	0, 1 ... 599, 600	2s	
Gn 79 Reset LO By Timer <i>Select whether Lockout is automatically reset after a time delay.</i>	Disabled, Enabled	Enabled	
Gn 79 Sequence Co-ord <i>Selects whether Sequence co-ordination functionality is used or not.</i>	Disabled, Enabled	Enabled	
Gn 79 Cold Load Action <i>Selects whether whist Cold Load is active the relay will perform only Delayed Trips or not.</i>	Off, Delayed	Off	

Description	Range	Default	Setting
Gn 79 Live Line Check <i>Selects whether the autoreclose requires a Live to Dead transition before AR is started.</i>	Disabled, Enabled	Disabled	
Gn 79 Check Sync During Deadtime <i>Selects whether the deadtime can be bypassed if the system comes into sync.</i>	Disabled, Enabled	Disabled	
Gn 79 LO Line VT Fail <i>Selects whether a Line VT Fail stops the Autoreclose.</i>	Disabled, Enabled	Disabled	
Gn 79 LO Bus VT Fail <i>Selects whether a Bus VT Fail stops the Autoreclose.</i>	Disabled, Enabled	Disabled	

3.7.2.1. P/F SHOTS

Description	Range	Default	Setting
Gn 79 P/F Prot'n Trip 1 <i>Selects whether the first phase fault trip is Instantaneous (Fast) or Delayed. When set to Delayed all P/F Inst Trips will be Inhibited for this shot.</i>	Inst, Delayed	Inst	
Gn 79 P/F Deadtime 1 <i>Time period between the fault being cleared and the close pulse being issued</i>	0.08, 0.1 ... 14300, 14400	5s	
Gn 79 P/F Prot'n Trip 2 <i>Selects whether the second phase fault trip is Instantaneous (Fast) or Delayed. When set to Delayed all P/F Inst Trips will be Inhibited for this shot.</i>	Inst, Delayed	Inst	
Gn 79 P/F Deadtime 2 <i>Time period between the fault being cleared and the close pulse being issued</i>	2, 2.1 ... 14300, 14400	5s	
Gn 79 P/F Prot'n Trip 3 <i>Selects whether the third phase fault trip is Instantaneous (Fast) or Delayed. When set to Delayed all P/F Inst Trips will be Inhibited for this shot.</i>	Inst, Delayed	Delayed	
Gn 79 P/F Deadtime 3 <i>Time period between the fault being cleared and the close pulse being issued</i>	2, 2.1 ... 14300, 14400	5s	
Gn 79 P/F Prot'n Trip 4 <i>Selects whether the fourth phase fault trip is Instantaneous (Fast) or Delayed. When set to Delayed all P/F Inst Trips will be Inhibited for this shot.</i>	Inst, Delayed	Delayed	
Gn 79 P/F Deadtime 4 <i>Time period between the fault being cleared and the close pulse being issued</i>	30, 30.1 ... 14300, 14400	30s	
Gn 79 P/F Prot'n Trip 5 <i>Selects whether the fifth phase fault trip is Instantaneous (Fast) or Delayed. When set to Delayed all P/F Inst Trips will be Inhibited for this shot.</i>	Inst, Delayed	Delayed	
Gn 79 P/F HS Trips To Lockout <i>Selects how many High Set trips are allowed before going to Lockout</i>	1, 2, 3, 4, 5	5	

Description	Range	Default	Setting
Gn 79 P/F Delayed Trips To Lockout <i>Selects how many Delayed trips are allowed before going to Lockout</i>	1, 2, 3, 4, 5	5	

3.7.2.2. E/F SHOTS

Description	Range	Default	Setting
Gn 79 E/F Prot'n Trip 1 <i>Selects whether the first earth fault trip is Instantaneous (Fast) or Delayed. When set to Delayed all E/F Inst Trips will be Inhibited for this shot.</i>	Inst, Delayed	Inst	
Gn 79 E/F Deadtime 1 <i>Time period between the fault being cleared and the close pulse being issued</i>	0.08, 0.1 ... 14300, 14400	5s	
Gn 79 E/F Prot'n Trip 2 <i>Selects whether the second earth fault trip is Instantaneous (Fast) or Delayed. When set to Delayed all E/F Inst Trips will be Inhibited for this shot.</i>	Inst, Delayed	Inst	
Gn 79 E/F Deadtime 2 <i>Time period between the fault being cleared and the close pulse being issued</i>	2, 2.1 ... 14300, 14400	5s	
Gn 79 E/F Prot'n Trip 3 <i>Selects whether the third earth fault trip is Instantaneous (Fast) or Delayed. When set to Delayed all E/F Inst Trips will be Inhibited for this shot.</i>	Inst, Delayed	Delayed	
Gn 79 E/F Deadtime 3 <i>Time period between the fault being cleared and the close pulse being issued</i>	2, 2.1 ... 14300, 14400	5s	
Gn 79 E/F Prot'n Trip 4 <i>Selects whether the fourth earth fault trip is Instantaneous (Fast) or Delayed. When set to Delayed all E/F Inst Trips will be Inhibited for this shot.</i>	Inst, Delayed	Delayed	
Gn 79 E/F Deadtime 4 <i>Time period between the fault being cleared and the close pulse being issued</i>	30, 30.1 ... 14300, 14400	30s	
Gn 79 E/F Prot'n Trip 5 <i>Selects whether the fifth earth fault trip is Instantaneous (Fast) or Delayed. When set to Delayed all E/F Inst Trips will be Inhibited for this shot.</i>	Inst, Delayed	Delayed	
Gn 79 E/F HS Trips To Lockout <i>Selects how many High Set trips are allowed before going to Lockout</i>	1, 2, 3, 4, 5	5	
Gn 79 E/F Delayed Trips To Lockout <i>Selects how many Delayed trips are allowed before going to Lockout</i>	1, 2, 3, 4, 5	5	

3.7.2.3. SEF Shots

Description	Range	Default	Setting
Gn 79 SEF Prot'n Trip 1 <i>Selects whether the first sensitive earth fault trip is Instantaneous or Delayed. When set to Delayed all SEF Inst Trips will be Inhibited for this shot.</i>	Inst, Delayed	Inst	
Gn 79 SEF Deadtime 1 <i>Time period between the fault being cleared and the close pulse being issued</i>	0.08, 0.1 ... 14300, 14400	5s	
Gn 79 SEF Prot'n Trip 2 <i>Selects whether the second sensitive earth fault trip is Instantaneous or Delayed. When set to Delayed all SEF Inst Trips will be Inhibited for this shot.</i>	Inst, Delayed	Inst	
Gn 79 SEF Deadtime 2 <i>Time period between the fault being cleared and the close pulse being issued</i>	2, 2.1 ... 14300, 14400	5s	
Gn 79 SEF Prot'n Trip 3 <i>Selects whether the third sensitive earth fault trip is Instantaneous or Delayed. When set to Delayed all SEF Inst Trips will be Inhibited for this shot.</i>	Inst, Delayed	Delayed	
Gn 79 SEF Deadtime 3 <i>Time period between the fault being cleared and the close pulse being issued</i>	2, 2.1 ... 14300, 14400	5s	
Gn 79 SEF Prot'n Trip 4 <i>Selects whether the fourth sensitive earth fault trip is Instantaneous or Delayed. When set to Delayed all SEF Inst Trips will be Inhibited for this shot.</i>	Inst, Delayed	Delayed	
Gn 79 SEF Deadtime 4 <i>Time period between the fault being cleared and the close pulse being issued</i>	30, 30.1 ... 14300, 14400	30s	
Gn 79 SEF Prot'n Trip 5 <i>Selects whether the fifth sensitive earth fault trip is Instantaneous or Delayed. When set to Delayed all SEF Inst Trips will be Inhibited for this shot.</i>	Inst, Delayed	Delayed	
Gn 79 SEF Delayed Trips To Lockout <i>Selects how many Delayed trips are allowed before going to Lockout</i>	1, 2, 3, 4, 5	5	

3.7.2.4. Extern Shots

Description	Range	Default	Setting
Gn 79 Extern Prot'n Trip 1 <i>Selects whether the first external trip is Instantaneous or Delayed</i>	Not Blocked, Blocked	Not Blocked	
Gn 79 Extern Deadtime 1 <i>Time period between the fault being cleared and the close pulse being issued</i>	0.08, 0.1 ... 14300, 14400	5s	
Gn 79 Extern Prot'n Trip 2 <i>Selects whether the second external trip is Instantaneous or Delayed</i>	Not Blocked, Blocked	Not Blocked	

Description	Range	Default	Setting
Gn 79 Extern Deadtime 2 <i>Time period between the fault being cleared and the close pulse being issued</i>	2, 2.1 ... 14300, 14400	5s	
Gn 79 Extern Prot'n Trip 3 <i>Selects whether the third external trip is Instantaneous or Delayed</i>	Not Blocked, Blocked	Not Blocked	
Gn 79 Extern Deadtime 3 <i>Time period between the fault being cleared and the close pulse being issued</i>	2, 2.1 ... 14300, 14400	5s	
Gn 79 Extern Prot'n Trip 4 <i>Selects whether the fourth external trip is Instantaneous or Delayed</i>	Not Blocked, Blocked	Not Blocked	
Gn 79 Extern Deadtime 4 <i>Time period between the fault being cleared and the close pulse being issued</i>	30, 30.1 ... 14300, 14400	30s	
Gn 79 Extern Prot'n Trip 5 <i>Selects whether the fifth external trip is Instantaneous or Delayed</i>	Not Blocked, Blocked	Not Blocked	
Gn 79 Extern Trips To Lockout <i>Selects how many external trips are allowed before going to Lockout</i>	1, 2, 3, 4, 5	5	

3.7.3. (Re)closure Mode

Description	Range	Default	Setting
Gn 79 Dead Bar Charge <i>Selects Autoreclose Dead Bar Charge closing condition</i>	Disabled, Enabled	Disabled	
Gn 79 Dead Line Charge <i>Selects Autoreclose Dead Line Charge closing condition</i>	Disabled, Enabled	Disabled	
Gn 79 Dead Line & Dead Bar Close <i>Selects Autoreclose Dead Line And Dead Bar Close closing condition</i>	Disabled, Enabled	Disabled	
Gn 79 Check Sync Close <i>Selects Autoreclose Check Sync Close closing condition. Has to be within Check or System Sync window.</i>	Disabled, Enabled	Disabled	
Gn 79 Unconditional Close <i>Selects Autoreclose Unconditional closing condition. Can close regardless of whether outside of CS/SS window</i>	Disabled, Enabled	Disabled	
Gn 79 DLC Delay <i>Selects a delay after Dead Line Close condition becomes valid</i>	0, 0.1 ... 59.9, 60	0s	
Gn 79 DBC Delay <i>Selects a delay after Dead Bar Close condition becomes valid</i>	0, 0.1 ... 59.9, 60	0s	
Gn Manual Close DBC <i>Selects Manual Close Dead Bar Charge closing condition</i>	Disabled, Enabled	Disabled	

Description	Range	Default	Setting
Gn Manual Close DLC <i>Selects Manual Close Dead Line Charge closing condition</i>	Disabled, Enabled	Disabled	
Gn Manual Close DLDB <i>Selects Manual Close Dead Line And Dead Bar Close closing condition</i>	Disabled, Enabled	Disabled	
Gn Manual Close CS <i>Selects Manual Close Check Sync Close closing condition</i>	Disabled, Enabled	Disabled	
Gn Unconditional Manual Close <i>Selects Manual Close Unconditional closing condition</i>	Disabled, Enabled	Disabled	
Gn Sync Close Window Enable <i>Selects whether to use a timed window or indefinite period to wait for synchronisation. This also applies to Dead Line & Dead Bar charging</i>	Disabled, Enabled	Enabled	
Gn Sync Close Window <i>Selects the timed window period</i>	0, 1 ... 1199, 1200	60s	

3.7.4. Synchronising Check

Description	Range	Default	Setting
Gn 25 Sync Voltages <i>Selects which phase voltage will be compared for in sync</i>	Van, Vbn, Vcn, Vab, Vbc, Vca	Vbn	
Gn 25 Dead Line <i>Selects the level to determine that the Line is de-energised</i>	0, 1 ... 149, 150	20%	
Gn 25 Live Line <i>Selects the level to determine that the Line is energised</i>	0, 1 ... 149, 150	90%	
Gn 25 Dead Bus <i>Selects the level to determine that the Bus is de-energised</i>	0, 1 ... 149, 150	20%	
Gn 25 Live Bus <i>Selects the level to determine that the Bus is energised</i>	0, 1 ... 149, 150	90%	
Gn 25 Line U/V <i>Selects whether the Line Undervoltage detector is enabled</i>	Disabled, Enabled	Enabled	
Gn 25 Line Undervolts <i>Selects the Line Undervoltage setting</i>	0, 1 ... 149, 150	90%	
Gn 25 Bus U/V <i>Selects whether the Bus Undervoltage detector is enabled</i>	Disabled, Enabled	Enabled	
Gn 25 Bus Undervolts <i>Selects the Bus Undervoltage setting</i>	0, 1 ... 149, 150	90%	
Gn 25 Voltage Diff <i>Selects whether the Voltage Differential detector is enabled</i>	Disabled, Enabled	Enabled	

Description	Range	Default	Setting
Gn 25 Volt Differential <i>Selects the Voltage Differential setting</i>	0, 1 ... 99, 100	10%	
Gn 25 Check Sync <i>Selects whether the Check Sync window is enabled</i>	Disabled, Enabled	Enabled	
Gn 25 Check Sync Angle <i>Selects the Check Sync Angle setting</i>	0, 1 ... 89, 90	20deg	
Gn 25 Check Sync Slip Freq <i>Selects whether the Check Sync Slip Frequency setting is used</i>	Disabled, Enabled	Enabled	
Gn 25 Check Sync Slip <i>Selects the Check Sync Slip Frequency setting</i>	0, 0.01 ... 1.99, 2	0.05Hz	
Gn 25 Check Sync Timer <i>Selects the Check Sync time delay before In Sync is issued</i>	0, 0.01 ... 99.99, 100	2s	
Gn 25 System Split Mode <i>Selects whether System Split is detected by either Phase Angle Or Slip Frequency</i>	Phase, Slip	Phase	
Gn 25 Split Angle <i>Selects the Angle at which System Split is detected</i>	0, 1 ... 179, 180	175deg	
Gn 25 Split Slip <i>Selects the Slip Frequency at which System Split is detected</i>	0, 0.01 ... 1.99, 2	0.02Hz	
Gn 25 System Sync <i>Selects whether the System Sync window is enabled</i>	Disabled, Enabled	Enabled	
Gn 25 System Sync Angle <i>Selects the System Sync Angle setting</i>	1, 2 ... 89, 90	10deg	
Gn 25 System Sync Slip <i>Selects the System Sync Slip Frequency setting</i>	0, 0.005 ... 1.995, 2	0.125Hz	
Gn 25 System Sync Timer <i>Selects the System Sync time delay setting</i>	0, 0.01 ... 99.99, 100	0.2s	
Gn 25 Close On Zero <i>Selects whether the Close On Zero function is enabled</i>	Disabled, Enabled	Enabled	
Gn 25 COZ Slip Freq <i>Selects the Close On Zero Slip Frequency setting</i>	0, 0.005 ... 1.995, 2	0.125Hz	
Gn 25 CB Close Time <i>Selects the circuit breaker close time for use with Close On Zero</i>	0, 1 ... 899, 900	60ms	
Gn 25 DAR Split Mode <i>Selects the mode which will be performed after System Split when performing Autoreclose</i>	CS, SS, COZ, LO	CS	
Gn 25 MC Split Mode <i>Selects the mode which will be performed after System Split when performing Manual Close</i>	CS, SS, COZ	CS	

3.7.5. Manual Close

Description	Range	Default	Setting
Gn Line Check Trip <i>Selects whether line check trip is enabled, if enabled no AR sequence initiated</i>	Disabled, Enabled	Enabled	
Gn P/F Line Check Trip <i>Selects whether a phase fault line check trip is Instantaneous (Fast) or Delayed. When set to Delayed all P/F Inst Trips will be Inhibited for this shot.</i>	Inst, Delayed	Inst	
Gn E/F Line Check Trip <i>Selects whether an earth fault line check trip is Instantaneous or Delayed. When set to Delayed all E/F Inst Trips will be Inhibited for this shot.</i>	Inst, Delayed	Inst	
Gn SEF Line Check Trip <i>Selects whether a sensitive earth fault line check trip is Instantaneous or Delayed. When set to Delayed all SEF Inst Trips will be Inhibited for this shot.</i>	Inst, Delayed	Inst	
Gn Extern Line Check Trip <i>Selects whether an external line check trip is Instantaneous (Fast) or Delayed</i>	Not Blocked, Blocked	Not Blocked	

3.7.6. Circuit Breaker

Description	Range	Default	Setting
Gn Close CB Delay <i>Delay between a Close CB control being received and the Close CB contacts being operated to allow operator walk away.</i>	0, 1 ... 59900, 60000	10000ms	
Gn Close CB Pulse <i>Specifies the duration of the circuit breaker close pulse</i>	0.1, 0.2 ... 59.9, 60	2s	
Gn Reclaim Timer <i>The period of time after a CB has closed and remained closed before the reclosure is deemed to be successful and the AR is re-initialised. If the CB remains open at the end of the reclaim time then the AR goes to lockout.</i>	0, 1 ... 599, 600	2s	
Gn Blocked Close Delay <i>Selects the maximum time that the manual Close CB may be blocked by interlocking before the command or control is cancelled. The relay will signal "Blocked by Interlocking".</i>	0, 1 ... 599, 600	5s	
Gn Open CB Delay <i>Delay between an Open CB control being received and the Open CB contacts being operated.</i>	0, 1 ... 59900, 60000	10000ms	
Gn Open CB Pulse <i>Selects the maximum time of the Open CB pulse. If the CB is not closed when this timer expires then an alarm will be raised to signify failure to close.</i>	0.1, 0.2, 0.3, 0.4, 0.5, 0.6, 0.7, 0.8, 0.9, 1, 1.1, 1.2, 1.3, 1.4, 1.5, 1.6, 1.7, 1.8, 1.9, 2	1s	

Description	Range	Default	Setting
Gn CB Travel Alarm <i>Selects the maximum time that the CB should take to either Open or Close before a failure is recorded.</i>	0.01, 0.02 ... 1.99, 2	1s	
Gn CB Controls Latched <i>Selects whether Binary Input triggers of Close CB and Open CB are latched.</i>	Disabled, Enabled	Enabled	

3.7.7. Quick Logic

Description	Range	Default	Setting
Quick Logic <i>Enable or Disable all logic equations</i>	Disabled, Enabled	Disabled	
E1 Equation <i>Enable or Disable logic equation E1</i>	Disabled, Enabled	Disabled	
E1 <i>Specify logic equations of the form $E_n = \langle \text{Operand} \rangle \langle \text{Operator} \rangle \langle \text{Operand} \rangle$ using the following: 0123456789=Digit() = Parenthesis! = NOT operation. = AND operation ^ = EXCLUSIVE OR operation E (followed by a digit) = Equation number F (Followed by a digit) = Function Key number I (Followed by a digit) = Binary Input number L (Followed by a digit) = LED number O (Followed by a digit) = output relay number V (Followed by a digit) = Virtual Input/Output number. Examples Make a function key LED toggle when function key is pressed (requires E1 to drive L11 in output matrix) $E1 = F3 \wedge L11$</i>	(20 Character String)		
E1 Pickup Delay <i>Time before equation output operates, after equation satisfied</i>	0, 0.01 ... 14300, 14400	0s	
E1 Dropoff Delay <i>Time before equation output resets, after equation no longer satisfied</i>	0, 0.01 ... 14300, 14400	0s	
E1 Counter Target <i>Select number of times equation must be satisfied before equation output operates</i>	1, 2 ... 998, 999	1	
E1 Counter Reset Mode <i>Select type of counter reset mode</i>	Off, Multi-shot, Single-shot	Off	
E1 Counter Reset Time <i>Select counter reset time</i>	0, 0.01 ... 14300, 14400	0s	
E2 Equation <i>Enable or Disable logic equation E2</i>	Disabled, Enabled	Disabled	

Description	Range	Default	Setting
<p>E2</p> <p>Specify logic equations of the form $E_n = \langle \text{Operand} \rangle \langle \text{Operator} \rangle \langle \text{Operand} \rangle$ using the following: 0123456789=Digit() = Parenthesis! = NOT operation. = AND operation ^ = EXCLUSIVE OR operation E (followed by a digit) = Equation number F (Followed by a digit) = Function Key number I (Followed by a digit) = Binary Input number L (Followed by a digit) = LED number O (Followed by a digit) = output relay number V (Followed by a digit) = Virtual Input/Output number. Examples Make a function key LED toggle when function key is pressed (requires E1 to drive L11 in output matrix) $E1 = F3 \wedge L11$</p>	(20 Character String)		
<p>E2 Pickup Delay</p> <p>Time before equation output operates, after equation satisfied</p>	0, 0.01 ... 14300, 14400	0s	
<p>E2 Dropoff Delay</p> <p>Time before equation output resets, after equation no longer satisfied</p>	0, 0.01 ... 14300, 14400	0s	
<p>E2 Counter Target</p> <p>Select number of times equation must be satisfied before equation output operates</p>	1, 2 ... 998, 999	1	
<p>E2 Counter Reset Mode</p> <p>Select type of counter reset mode</p>	Off, Multi-shot, Single-shot	Off	
<p>E2 Counter Reset Time</p> <p>Select counter reset time</p>	0, 0.01 ... 14300, 14400	0s	
<p>E3 Equation</p> <p>Enable or Disable logic equation E3</p>	Disabled, Enabled	Disabled	
<p>E3</p> <p>Specify logic equations of the form $E_n = \langle \text{Operand} \rangle \langle \text{Operator} \rangle \langle \text{Operand} \rangle$ using the following: 0123456789=Digit() = Parenthesis! = NOT operation. = AND operation ^ = EXCLUSIVE OR operation E (followed by a digit) = Equation number F (Followed by a digit) = Function Key number I (Followed by a digit) = Binary Input number L (Followed by a digit) = LED number O (Followed by a digit) = output relay number V (Followed by a digit) = Virtual Input/Output number. Examples Make a function key LED toggle when function key is pressed (requires E1 to drive L11 in output matrix) $E1 = F3 \wedge L11$</p>	(20 Character String)		
<p>E3 Pickup Delay</p> <p>Time before equation output operates, after equation satisfied</p>	0, 0.01 ... 14300, 14400	0s	
<p>E3 Dropoff Delay</p> <p>Time before equation output resets, after equation no longer satisfied</p>	0, 0.01 ... 14300, 14400	0s	
<p>E3 Counter Target</p> <p>Select number of times equation must be satisfied before equation output operates</p>	1, 2 ... 998, 999	1	
<p>E3 Counter Reset Mode</p> <p>Select type of counter reset mode</p>	Off, Multi-shot, Single-shot	Off	

Description	Range	Default	Setting
E3 Counter Reset Time <i>Select counter reset time</i>	0, 0.01 ... 14300, 14400	0s	
E4 Equation <i>Enable or Disable logic equation E4</i>	Disabled, Enabled	Disabled	
E4 <i>Specify logic equations of the form En = <Operand><Operator><Operand>using the following:0123456789=Digit() = Parenthesis! = NOT operation. = AND operation^ = EXCLUSIVE OR operationE(followed by a digit) = Equation numberF (Followed by a digit) = Function Key numberI(Followed by a digit) = Binary Input numberL(Followed by a digit) = LED numberO(Followed by a digit) = output relay numberV(Followed by a digit) =Virtual Input/Output number.ExamplesMake a function key LED toggle when function key is pressed (requires E1 to drive L11 in output matrix)E1 = F3^L11</i>	(20 Character String)		
E4 Pickup Delay <i>Time before equation output operates, after equation satisfied</i>	0, 0.01 ... 14300, 14400	0s	
E4 Dropoff Delay <i>Time before equation output resets, after equation no longer satisfied</i>	0, 0.01 ... 14300, 14400	0s	
E4 Counter Target <i>Select number of times equation must be satisfied before equation output operates</i>	1, 2 ... 998, 999	1	
E4 Counter Reset Mode <i>Select type of counter reset mode</i>	Off, Multi-shot, Single-shot	Off	
E4 Counter Reset Time <i>Select counter reset time</i>	0, 0.01 ... 14300, 14400	0s	
E5 Equation <i>Enable or Disable logic equation E5</i>	Disabled, Enabled	Disabled	
E5 <i>Specify logic equations of the form En = <Operand><Operator><Operand>using the following:0123456789=Digit() = Parenthesis! = NOT operation. = AND operation^ = EXCLUSIVE OR operationE(followed by a digit) = Equation numberF (Followed by a digit) = Function Key numberI(Followed by a digit) = Binary Input numberL(Followed by a digit) = LED numberO(Followed by a digit) = output relay numberV(Followed by a digit) =Virtual Input/Output number.ExamplesMake a function key LED toggle when function key is pressed (requires E1 to drive L11 in output matrix)E1 = F3^L11</i>	(20 Character String)		
E5 Pickup Delay <i>Time before equation output operates, after equation satisfied</i>	0, 0.01 ... 14300, 14400	0s	
E5 Dropoff Delay <i>Time before equation output resets, after equation no longer satisfied</i>	0, 0.01 ... 14300, 14400	0s	

Description	Range	Default	Setting
E5 Counter Target <i>Select number of times equation must be satisfied before equation output operates</i>	1, 2 ... 998, 999	1	
E5 Counter Reset Mode <i>Select type of counter reset mode</i>	Off, Multi-shot, Single-shot	Off	
E5 Counter Reset Time <i>Select counter reset time</i>	0, 0.01 ... 14300, 14400	0s	
E6 Equation <i>Enable or Disable logic equation E6</i>	Disabled, Enabled	Disabled	
E6 <i>Specify logic equations of the form En = <Operand><Operator><Operand>using the following:0123456789=Digit() = Parenthesis! = NOT operation. = AND operation^ = EXCLUSIVE OR operationE(followed by a digit) = Equation numberF (Followed by a digit) = Function Key numberI(Followed by a digit) = Binary Input numberL(Followed by a digit) = LED numberO(Followed by a digit) = output relay numberV(Followed by a digit) =Virtual Input/Output number.ExamplesMake a function key LED toggle when function key is pressed (requires E1 to drive L11 in output matrix)E1 = F3^L11</i>	(20 Character String)		
E6 Pickup Delay <i>Time before equation output operates, after equation satisfied</i>	0, 0.01 ... 14300, 14400	0s	
E6 Droptoff Delay <i>Time before equation output resets, after equation no longer satisfied</i>	0, 0.01 ... 14300, 14400	0s	
E6 Counter Target <i>Select number of times equation must be satisfied before equation output operates</i>	1, 2 ... 998, 999	1	
E6 Counter Reset Mode <i>Select type of counter reset mode</i>	Off, Multi-shot, Single-shot	Off	
E6 Counter Reset Time <i>Select counter reset time</i>	0, 0.01 ... 14300, 14400	0s	
E7 Equation <i>Enable or Disable logic equation E7</i>	Disabled, Enabled	Disabled	
E7 <i>Specify logic equations of the form En = <Operand><Operator><Operand>using the following:0123456789=Digit() = Parenthesis! = NOT operation. = AND operation^ = EXCLUSIVE OR operationE(followed by a digit) = Equation numberF (Followed by a digit) = Function Key numberI(Followed by a digit) = Binary Input numberL(Followed by a digit) = LED numberO(Followed by a digit) = output relay numberV(Followed by a digit) =Virtual Input/Output number.ExamplesMake a function key LED toggle when function key is pressed (requires E1 to drive L11 in output matrix)E1 = F3^L11</i>	(20 Character String)		

Description	Range	Default	Setting
E7 Pickup Delay <i>Time before equation output operates, after equation satisfied</i>	0, 0.01 ... 14300, 14400	0s	
E7 Dropoff Delay <i>Time before equation output resets, after equation no longer satisfied</i>	0, 0.01 ... 14300, 14400	0s	
E7 Counter Target <i>Select number of times equation must be satisfied before equation output operates</i>	1, 2 ... 998, 999	1	
E7 Counter Reset Mode <i>Select type of counter reset mode</i>	Off, Multi-shot, Single-shot	Off	
E7 Counter Reset Time <i>Select counter reset time</i>	0, 0.01 ... 14300, 14400	0s	
E8 Equation <i>Enable or Disable logic equation E8</i>	Disabled, Enabled	Disabled	
E8 <i>Specify logic equations of the form En = <Operand><Operator><Operand> using the following: 0123456789=Digit() = Parenthesis! = NOT operation. = AND operation ^ = EXCLUSIVE OR operation E (followed by a digit) = Equation number F (Followed by a digit) = Function Key number L (Followed by a digit) = Binary Input number L (Followed by a digit) = LED number O (Followed by a digit) = output relay number V (Followed by a digit) = Virtual Input/Output number. Examples Make a function key LED toggle when function key is pressed (requires E1 to drive L11 in output matrix) E1 = F3^L11</i>	(20 Character String)		
E8 Pickup Delay <i>Time before equation output operates, after equation satisfied</i>	0, 0.01 ... 14300, 14400	0s	
E8 Dropoff Delay <i>Time before equation output resets, after equation no longer satisfied</i>	0, 0.01 ... 14300, 14400	0s	
E8 Counter Target <i>Select number of times equation must be satisfied before equation output operates</i>	1, 2 ... 998, 999	1	
E8 Counter Reset Mode <i>Select type of counter reset mode</i>	Off, Multi-shot, Single-shot	Off	
E8 Counter Reset Time <i>Select counter reset time</i>	0, 0.01 ... 14300, 14400	0s	
E9 Equation <i>Enable or Disable logic equation E9</i>	Disabled, Enabled	Disabled	

Description	Range	Default	Setting
E9 Specify logic equations of the form $E_n = \langle \text{Operand} \rangle \langle \text{Operator} \rangle \langle \text{Operand} \rangle$ using the following: 0123456789=Digit() = Parenthesis! = NOT operation. = AND operation ^ = EXCLUSIVE OR operation E (followed by a digit) = Equation number F (Followed by a digit) = Function Key number I (Followed by a digit) = Binary Input number L (Followed by a digit) = LED number O (Followed by a digit) = output relay number V (Followed by a digit) = Virtual Input/Output number. Examples Make a function key LED toggle when function key is pressed (requires E1 to drive L11 in output matrix) $E1 = F3 \wedge L11$	(20 Character String)		
E9 Pickup Delay Time before equation output operates, after equation satisfied	0, 0.01 ... 14300, 14400	0s	
E9 Dropoff Delay Time before equation output resets, after equation no longer satisfied	0, 0.01 ... 14300, 14400	0s	
E9 Counter Target Select number of times equation must be satisfied before equation output operates	1, 2 ... 998, 999	1	
E9 Counter Reset Mode Select type of counter reset mode	Off, Multi-shot, Single-shot	Off	
E9 Counter Reset Time Select counter reset time	0, 0.01 ... 14300, 14400	0s	
E10 Equation Enable or Disable logic equation E10	Disabled, Enabled	Disabled	
E10 Specify logic equations of the form $E_n = \langle \text{Operand} \rangle \langle \text{Operator} \rangle \langle \text{Operand} \rangle$ using the following: 0123456789=Digit() = Parenthesis! = NOT operation. = AND operation ^ = EXCLUSIVE OR operation E (followed by a digit) = Equation number F (Followed by a digit) = Function Key number I (Followed by a digit) = Binary Input number L (Followed by a digit) = LED number O (Followed by a digit) = output relay number V (Followed by a digit) = Virtual Input/Output number. Examples Make a function key LED toggle when function key is pressed (requires E1 to drive L11 in output matrix) $E1 = F3 \wedge L11$	(20 Character String)		
E10 Pickup Delay Time before equation output operates, after equation satisfied	0, 0.01 ... 14300, 14400	0s	
E10 Dropoff Delay Time before equation output resets, after equation no longer satisfied	0, 0.01 ... 14300, 14400	0s	
E10 Counter Target Select number of times equation must be satisfied before equation output operates	1, 2 ... 998, 999	1	
E10 Counter Reset Mode Select type of counter reset mode	Off, Multi-shot, Single-shot	Off	

Description	Range	Default	Setting
E10 Counter Reset Time <i>Select counter reset time</i>	0, 0.01 ... 14300, 14400	0s	
E11 Equation <i>Enable or Disable logic equation E11</i>	Disabled, Enabled	Disabled	
E11 <i>Specify logic equations of the form En = <Operand><Operator><Operand>using the following:0123456789=Digit() = Parenthesis! = NOT operation. = AND operation^ = EXCLUSIVE OR operationE(followed by a digit) = Equation numberF (Followed by a digit) = Function Key numberI(Followed by a digit) = Binary Input numberL(Followed by a digit) = LED numberO(Followed by a digit) = output relay numberV(Followed by a digit) =Virtual Input/Output number.ExamplesMake a function key LED toggle when function key is pressed (requires E1 to drive L11 in output matrix)E1 = F3^L11</i>	(20 Character String)		
E11 Pickup Delay <i>Time before equation output operates, after equation satisfied</i>	0, 0.01 ... 14300, 14400	0s	
E11 Dropoff Delay <i>Time before equation output resets, after equation no longer satisfied</i>	0, 0.01 ... 14300, 14400	0s	
E11 Counter Target <i>Select number of times equation must be satisfied before equation output operates</i>	1, 2 ... 998, 999	1	
E11 Counter Reset Mode <i>Select type of counter reset mode</i>	Off, Multi-shot, Single-shot	Off	
E11 Counter Reset Time <i>Select counter reset time</i>	0, 0.01 ... 14300, 14400	0s	
E12 Equation <i>Enable or Disable logic equation E12</i>	Disabled, Enabled	Disabled	
E12 <i>Specify logic equations of the form En = <Operand><Operator><Operand>using the following:0123456789=Digit() = Parenthesis! = NOT operation. = AND operation^ = EXCLUSIVE OR operationE(followed by a digit) = Equation numberF (Followed by a digit) = Function Key numberI(Followed by a digit) = Binary Input numberL(Followed by a digit) = LED numberO(Followed by a digit) = output relay numberV(Followed by a digit) =Virtual Input/Output number.ExamplesMake a function key LED toggle when function key is pressed (requires E1 to drive L11 in output matrix)E1 = F3^L11</i>	(20 Character String)		
E12 Pickup Delay <i>Time before equation output operates, after equation satisfied</i>	0, 0.01 ... 14300, 14400	0s	
E12 Dropoff Delay <i>Time before equation output resets, after equation no longer satisfied</i>	0, 0.01 ... 14300, 14400	0s	

Description	Range	Default	Setting
E12 Counter Target <i>Select number of times equation must be satisfied before equation output operates</i>	1, 2 ... 998, 999	1	
E12 Counter Reset Mode <i>Select type of counter reset mode</i>	Off, Multi-shot, Single-shot	Off	
E12 Counter Reset Time <i>Select counter reset time</i>	0, 0.01 ... 14300, 14400	0s	
E13 Equation <i>Enable or Disable logic equation E13</i>	Disabled, Enabled	Disabled	
E13 <i>Specify logic equations of the form En = <Operand><Operator><Operand>using the following:0123456789=Digit() = Parenthesis! = NOT operation. = AND operation^ = EXCLUSIVE OR operationE(followed by a digit) = Equation numberF (Followed by a digit) = Function Key numberI(Followed by a digit) = Binary Input numberL(Followed by a digit) = LED numberO(Followed by a digit) = output relay numberV(Followed by a digit) =Virtual Input/Output number.ExamplesMake a function key LED toggle when function key is pressed (requires E1 to drive L11 in output matrix)E1 = F3^L11</i>	(20 Character String)		
E13 Pickup Delay <i>Time before equation output operates, after equation satisfied</i>	0, 0.01 ... 14300, 14400	0s	
E13 Dropoff Delay <i>Time before equation output resets, after equation no longer satisfied</i>	0, 0.01 ... 14300, 14400	0s	
E13 Counter Target <i>Select number of times equation must be satisfied before equation output operates</i>	1, 2 ... 998, 999	1	
E13 Counter Reset Mode <i>Select type of counter reset mode</i>	Off, Multi-shot, Single-shot	Off	
E13 Counter Reset Time <i>Select counter reset time</i>	0, 0.01 ... 14300, 14400	0s	
E14 Equation <i>Enable or Disable logic equation E14</i>	Disabled, Enabled	Disabled	
E14 <i>Specify logic equations of the form En = <Operand><Operator><Operand>using the following:0123456789=Digit() = Parenthesis! = NOT operation. = AND operation^ = EXCLUSIVE OR operationE(followed by a digit) = Equation numberF (Followed by a digit) = Function Key numberI(Followed by a digit) = Binary Input numberL(Followed by a digit) = LED numberO(Followed by a digit) = output relay numberV(Followed by a digit) =Virtual Input/Output number.ExamplesMake a function key LED toggle when function key is pressed (requires E1 to drive L11 in output matrix)E1 = F3^L11</i>	(20 Character String)		

Description	Range	Default	Setting
E14 Pickup Delay <i>Time before equation output operates, after equation satisfied</i>	0, 0.01 ... 14300, 14400	0s	
E14 Dropoff Delay <i>Time before equation output resets, after equation no longer satisfied</i>	0, 0.01 ... 14300, 14400	0s	
E14 Counter Target <i>Select number of times equation must be satisfied before equation output operates</i>	1, 2 ... 998, 999	1	
E14 Counter Reset Mode <i>Select type of counter reset mode</i>	Off, Multi-shot, Single-shot	Off	
E14 Counter Reset Time <i>Select counter reset time</i>	0, 0.01 ... 14300, 14400	0s	
E15 Equation <i>Enable or Disable logic equation E15</i>	Disabled, Enabled	Disabled	
E15 <i>Specify logic equations of the form En = <Operand><Operator><Operand> using the following: 0123456789=Digit() = Parenthesis! = NOT operation. = AND operation ^ = EXCLUSIVE OR operation E (followed by a digit) = Equation number F (Followed by a digit) = Function Key number I (Followed by a digit) = Binary Input number L (Followed by a digit) = LED number O (Followed by a digit) = output relay number V (Followed by a digit) = Virtual Input/Output number. Examples Make a function key LED toggle when function key is pressed (requires E1 to drive L11 in output matrix) E1 = F3^L11</i>	(20 Character String)		
E15 Pickup Delay <i>Time before equation output operates, after equation satisfied</i>	0, 0.01 ... 14300, 14400	0s	
E15 Dropoff Delay <i>Time before equation output resets, after equation no longer satisfied</i>	0, 0.01 ... 14300, 14400	0s	
E15 Counter Target <i>Select number of times equation must be satisfied before equation output operates</i>	1, 2 ... 998, 999	1	
E15 Counter Reset Mode <i>Select type of counter reset mode</i>	Off, Multi-shot, Single-shot	Off	
E15 Counter Reset Time <i>Select counter reset time</i>	0, 0.01 ... 14300, 14400	0s	
E16 Equation <i>Enable or Disable logic equation E16</i>	Disabled, Enabled	Disabled	

Description	Range	Default	Setting
<p>E16</p> <p>Specify logic equations of the form $E_n = \langle \text{Operand} \rangle \langle \text{Operator} \rangle \langle \text{Operand} \rangle$ using the following: 0123456789=Digit() = Parenthesis! = NOT operation. = AND operation ^ = EXCLUSIVE OR operation E (followed by a digit) = Equation number F (Followed by a digit) = Function Key number I (Followed by a digit) = Binary Input number L (Followed by a digit) = LED number O (Followed by a digit) = output relay number V (Followed by a digit) = Virtual Input/Output number. Examples Make a function key LED toggle when function key is pressed (requires E1 to drive L11 in output matrix) $E1 = F3 \wedge L11$</p>	(20 Character String)		
<p>E16 Pickup Delay</p> <p>Time before equation output operates, after equation satisfied</p>	0, 0.01 ... 14300, 14400	0s	
<p>E16 Dropoff Delay</p> <p>Time before equation output resets, after equation no longer satisfied</p>	0, 0.01 ... 14300, 14400	0s	
<p>E16 Counter Target</p> <p>Select number of times equation must be satisfied before equation output operates</p>	1, 2 ... 998, 999	1	
<p>E16 Counter Reset Mode</p> <p>Select type of counter reset mode</p>	Off, Multi-shot, Single-shot	Off	
<p>E16 Counter Reset Time</p> <p>Select counter reset time</p>	0, 0.01 ... 14300, 14400	0s	

3.8. Input Config

3.8.1. Input Matrix

Description	Range	Default	Setting
Inhibit 51-1 <i>Selects which inputs inhibit the 51-1 element</i>	Combination of (BI1, BI2, BI3, BI4, BI5, BI6, BI7, BI8, BI9, BI10, BI11, BI12, BI13, BI14, BI15, BI16, BI17, BI18, BI19, BI20, BI21, BI22, BI23, BI24, BI25, BI26, BI27, BI28, BI29, BI30, BI31, BI32, BI33, V1, V2, V3, V4, V5, V6, V7, V8, V9, V10, V11, V12, V13, V14, V15, V16)	----- ----- -----	
Inhibit 51-2 <i>Selects which inputs inhibit the 51-2 element</i>	Combination of (BI1, BI2, BI3, BI4, BI5, BI6, BI7, BI8, BI9, BI10, BI11, BI12, BI13, BI14, BI15, BI16, BI17, BI18, BI19, BI20, BI21, BI22, BI23, BI24, BI25, BI26, BI27, BI28, BI29, BI30, BI31, BI32, BI33, V1, V2, V3, V4, V5, V6, V7, V8, V9, V10, V11, V12, V13, V14, V15, V16)	----- ----- -----	
Inhibit 51-3 <i>Selects which inputs inhibit the 51-3 element</i>	Combination of (BI1, BI2, BI3, BI4, BI5, BI6, BI7, BI8, BI9, BI10, BI11, BI12, BI13, BI14, BI15, BI16, BI17, BI18, BI19, BI20, BI21, BI22, BI23, BI24, BI25, BI26, BI27, BI28, BI29, BI30, BI31, BI32, BI33, V1, V2, V3, V4, V5, V6, V7, V8, V9, V10, V11, V12, V13, V14, V15, V16)	----- ----- -----	
Inhibit 51-4 <i>Selects which inputs inhibit the 51-4 element</i>	Combination of (BI1, BI2, BI3, BI4, BI5, BI6, BI7, BI8, BI9, BI10, BI11, BI12, BI13, BI14, BI15, BI16, BI17, BI18, BI19, BI20, BI21, BI22, BI23, BI24, BI25, BI26, BI27, BI28, BI29, BI30, BI31, BI32, BI33, V1, V2, V3, V4, V5, V6, V7, V8, V9, V10, V11, V12, V13, V14, V15, V16)	----- ----- -----	
Inhibit 50-1 <i>Selects which inputs inhibit the 50-1 element</i>	Combination of (BI1, BI2, BI3, BI4, BI5, BI6, BI7, BI8, BI9, BI10, BI11, BI12, BI13, BI14, BI15, BI16, BI17, BI18, BI19, BI20, BI21, BI22, BI23, BI24, BI25, BI26, BI27, BI28, BI29, BI30, BI31, BI32, BI33, V1, V2, V3, V4, V5, V6, V7, V8, V9, V10, V11, V12, V13, V14, V15, V16)	----- ----- -----	

Description	Range	Default	Setting
Inhibit 50-2 <i>Selects which inputs inhibit the 50-2 element</i>	Combination of (BI1, BI2, BI3, BI4, BI5, BI6, BI7, BI8, BI9, BI10, BI11, BI12, BI13, BI14, BI15, BI16, BI17, BI18, BI19, BI20, BI21, BI22, BI23, BI24, BI25, BI26, BI27, BI28, BI29, BI30, BI31, BI32, BI33, V1, V2, V3, V4, V5, V6, V7, V8, V9, V10, V11, V12, V13, V14, V15, V16)	----- ----- -----	
Inhibit 50-3 <i>Selects which inputs inhibit the 50-3 element</i>	Combination of (BI1, BI2, BI3, BI4, BI5, BI6, BI7, BI8, BI9, BI10, BI11, BI12, BI13, BI14, BI15, BI16, BI17, BI18, BI19, BI20, BI21, BI22, BI23, BI24, BI25, BI26, BI27, BI28, BI29, BI30, BI31, BI32, BI33, V1, V2, V3, V4, V5, V6, V7, V8, V9, V10, V11, V12, V13, V14, V15, V16)	----- ----- -----	
Inhibit 50-4 <i>Selects which inputs inhibit the 50-4 element</i>	Combination of (BI1, BI2, BI3, BI4, BI5, BI6, BI7, BI8, BI9, BI10, BI11, BI12, BI13, BI14, BI15, BI16, BI17, BI18, BI19, BI20, BI21, BI22, BI23, BI24, BI25, BI26, BI27, BI28, BI29, BI30, BI31, BI32, BI33, V1, V2, V3, V4, V5, V6, V7, V8, V9, V10, V11, V12, V13, V14, V15, V16)	----- ----- -----	
Inhibit 51G-1 <i>Selects which inputs inhibit the 51G-1 element</i>	Combination of (BI1, BI2, BI3, BI4, BI5, BI6, BI7, BI8, BI9, BI10, BI11, BI12, BI13, BI14, BI15, BI16, BI17, BI18, BI19, BI20, BI21, BI22, BI23, BI24, BI25, BI26, BI27, BI28, BI29, BI30, BI31, BI32, BI33, V1, V2, V3, V4, V5, V6, V7, V8, V9, V10, V11, V12, V13, V14, V15, V16)	----- ----- -----	
Inhibit 51G-2 <i>Selects which inputs inhibit the 51G-2 element</i>	Combination of (BI1, BI2, BI3, BI4, BI5, BI6, BI7, BI8, BI9, BI10, BI11, BI12, BI13, BI14, BI15, BI16, BI17, BI18, BI19, BI20, BI21, BI22, BI23, BI24, BI25, BI26, BI27, BI28, BI29, BI30, BI31, BI32, BI33, V1, V2, V3, V4, V5, V6, V7, V8, V9, V10, V11, V12, V13, V14, V15, V16)	----- ----- -----	
Inhibit 51G-3 <i>Selects which inputs inhibit the 51G-3 element</i>	Combination of (BI1, BI2, BI3, BI4, BI5, BI6, BI7, BI8, BI9, BI10, BI11, BI12, BI13, BI14, BI15, BI16, BI17, BI18, BI19, BI20, BI21, BI22, BI23, BI24, BI25, BI26, BI27, BI28, BI29, BI30, BI31, BI32, BI33, V1, V2, V3, V4, V5, V6, V7, V8, V9, V10, V11, V12, V13, V14, V15, V16)	----- ----- -----	

Description	Range	Default	Setting
Inhibit 51G-4 <i>Selects which inputs inhibit the 51G-4 element</i>	Combination of (BI1, BI2, BI3, BI4, BI5, BI6, BI7, BI8, BI9, BI10, BI11, BI12, BI13, BI14, BI15, BI16, BI17, BI18, BI19, BI20, BI21, BI22, BI23, BI24, BI25, BI26, BI27, BI28, BI29, BI30, BI31, BI32, BI33, V1, V2, V3, V4, V5, V6, V7, V8, V9, V10, V11, V12, V13, V14, V15, V16)	----- ----- -----	
Inhibit 50G-1 <i>Selects which inputs inhibit the 50G-1 element</i>	Combination of (BI1, BI2, BI3, BI4, BI5, BI6, BI7, BI8, BI9, BI10, BI11, BI12, BI13, BI14, BI15, BI16, BI17, BI18, BI19, BI20, BI21, BI22, BI23, BI24, BI25, BI26, BI27, BI28, BI29, BI30, BI31, BI32, BI33, V1, V2, V3, V4, V5, V6, V7, V8, V9, V10, V11, V12, V13, V14, V15, V16)	----- ----- -----	
Inhibit 50G-2 <i>Selects which inputs inhibit the 50G-2 element</i>	Combination of (BI1, BI2, BI3, BI4, BI5, BI6, BI7, BI8, BI9, BI10, BI11, BI12, BI13, BI14, BI15, BI16, BI17, BI18, BI19, BI20, BI21, BI22, BI23, BI24, BI25, BI26, BI27, BI28, BI29, BI30, BI31, BI32, BI33, V1, V2, V3, V4, V5, V6, V7, V8, V9, V10, V11, V12, V13, V14, V15, V16)	----- ----- -----	
Inhibit 50G-3 <i>Selects which inputs inhibit the 50G-3 element</i>	Combination of (BI1, BI2, BI3, BI4, BI5, BI6, BI7, BI8, BI9, BI10, BI11, BI12, BI13, BI14, BI15, BI16, BI17, BI18, BI19, BI20, BI21, BI22, BI23, BI24, BI25, BI26, BI27, BI28, BI29, BI30, BI31, BI32, BI33, V1, V2, V3, V4, V5, V6, V7, V8, V9, V10, V11, V12, V13, V14, V15, V16)	----- ----- -----	
Inhibit 50G-4 <i>Selects which inputs inhibit the 50G-4 element</i>	Combination of (BI1, BI2, BI3, BI4, BI5, BI6, BI7, BI8, BI9, BI10, BI11, BI12, BI13, BI14, BI15, BI16, BI17, BI18, BI19, BI20, BI21, BI22, BI23, BI24, BI25, BI26, BI27, BI28, BI29, BI30, BI31, BI32, BI33, V1, V2, V3, V4, V5, V6, V7, V8, V9, V10, V11, V12, V13, V14, V15, V16)	----- ----- -----	
Inhibit 51SEF-1 <i>Selects which inputs inhibit the 51SEF-1 element</i>	Combination of (BI1, BI2, BI3, BI4, BI5, BI6, BI7, BI8, BI9, BI10, BI11, BI12, BI13, BI14, BI15, BI16, BI17, BI18, BI19, BI20, BI21, BI22, BI23, BI24, BI25, BI26, BI27, BI28, BI29, BI30, BI31, BI32, BI33, V1, V2, V3, V4, V5, V6, V7, V8, V9, V10, V11, V12, V13, V14, V15, V16)	----- ----- -----	

Description	Range	Default	Setting
Inhibit 51SEF-2 <i>Selects which inputs inhibit the 51SEF-2 element</i>	Combination of (BI1, BI2, BI3, BI4, BI5, BI6, BI7, BI8, BI9, BI10, BI11, BI12, BI13, BI14, BI15, BI16, BI17, BI18, BI19, BI20, BI21, BI22, BI23, BI24, BI25, BI26, BI27, BI28, BI29, BI30, BI31, BI32, BI33, V1, V2, V3, V4, V5, V6, V7, V8, V9, V10, V11, V12, V13, V14, V15, V16)	----- ----- -----	
Inhibit 51SEF-3 <i>Selects which inputs inhibit the 51SEF-3 element</i>	Combination of (BI1, BI2, BI3, BI4, BI5, BI6, BI7, BI8, BI9, BI10, BI11, BI12, BI13, BI14, BI15, BI16, BI17, BI18, BI19, BI20, BI21, BI22, BI23, BI24, BI25, BI26, BI27, BI28, BI29, BI30, BI31, BI32, BI33, V1, V2, V3, V4, V5, V6, V7, V8, V9, V10, V11, V12, V13, V14, V15, V16)	----- ----- -----	
Inhibit 51SEF-4 <i>Selects which inputs inhibit the 51SEF-4 element</i>	Combination of (BI1, BI2, BI3, BI4, BI5, BI6, BI7, BI8, BI9, BI10, BI11, BI12, BI13, BI14, BI15, BI16, BI17, BI18, BI19, BI20, BI21, BI22, BI23, BI24, BI25, BI26, BI27, BI28, BI29, BI30, BI31, BI32, BI33, V1, V2, V3, V4, V5, V6, V7, V8, V9, V10, V11, V12, V13, V14, V15, V16)	----- ----- -----	
Inhibit 50SEF-1 <i>Selects which inputs inhibit the 50SEF-1 element</i>	Combination of (BI1, BI2, BI3, BI4, BI5, BI6, BI7, BI8, BI9, BI10, BI11, BI12, BI13, BI14, BI15, BI16, BI17, BI18, BI19, BI20, BI21, BI22, BI23, BI24, BI25, BI26, BI27, BI28, BI29, BI30, BI31, BI32, BI33, V1, V2, V3, V4, V5, V6, V7, V8, V9, V10, V11, V12, V13, V14, V15, V16)	----- ----- -----	
Inhibit 50SEF-2 <i>Selects which inputs inhibit the 50SEF-2 element</i>	Combination of (BI1, BI2, BI3, BI4, BI5, BI6, BI7, BI8, BI9, BI10, BI11, BI12, BI13, BI14, BI15, BI16, BI17, BI18, BI19, BI20, BI21, BI22, BI23, BI24, BI25, BI26, BI27, BI28, BI29, BI30, BI31, BI32, BI33, V1, V2, V3, V4, V5, V6, V7, V8, V9, V10, V11, V12, V13, V14, V15, V16)	----- ----- -----	
Inhibit 50SEF-3 <i>Selects which inputs inhibit the 50SEF-3 element</i>	Combination of (BI1, BI2, BI3, BI4, BI5, BI6, BI7, BI8, BI9, BI10, BI11, BI12, BI13, BI14, BI15, BI16, BI17, BI18, BI19, BI20, BI21, BI22, BI23, BI24, BI25, BI26, BI27, BI28, BI29, BI30, BI31, BI32, BI33, V1, V2, V3, V4, V5, V6, V7, V8, V9, V10, V11, V12, V13, V14, V15, V16)	----- ----- -----	

Description	Range	Default	Setting
Inhibit 50SEF-4 <i>Selects which inputs inhibit the 50SEF-4 element</i>	Combination of (BI1, BI2, BI3, BI4, BI5, BI6, BI7, BI8, BI9, BI10, BI11, BI12, BI13, BI14, BI15, BI16, BI17, BI18, BI19, BI20, BI21, BI22, BI23, BI24, BI25, BI26, BI27, BI28, BI29, BI30, BI31, BI32, BI33, V1, V2, V3, V4, V5, V6, V7, V8, V9, V10, V11, V12, V13, V14, V15, V16)	----- ----- -----	
Inhibit 64H <i>Selects which inputs inhibit the 64H element</i>	Combination of (BI1, BI2, BI3, BI4, BI5, BI6, BI7, BI8, BI9, BI10, BI11, BI12, BI13, BI14, BI15, BI16, BI17, BI18, BI19, BI20, BI21, BI22, BI23, BI24, BI25, BI26, BI27, BI28, BI29, BI30, BI31, BI32, BI33, V1, V2, V3, V4, V5, V6, V7, V8, V9, V10, V11, V12, V13, V14, V15, V16)	----- ----- -----	
Inhibit 46IT <i>Selects which inputs inhibit the 46IT element</i>	Combination of (BI1, BI2, BI3, BI4, BI5, BI6, BI7, BI8, BI9, BI10, BI11, BI12, BI13, BI14, BI15, BI16, BI17, BI18, BI19, BI20, BI21, BI22, BI23, BI24, BI25, BI26, BI27, BI28, BI29, BI30, BI31, BI32, BI33, V1, V2, V3, V4, V5, V6, V7, V8, V9, V10, V11, V12, V13, V14, V15, V16)	----- ----- -----	
Inhibit 46DT <i>Selects which inputs inhibit the 46DT element</i>	Combination of (BI1, BI2, BI3, BI4, BI5, BI6, BI7, BI8, BI9, BI10, BI11, BI12, BI13, BI14, BI15, BI16, BI17, BI18, BI19, BI20, BI21, BI22, BI23, BI24, BI25, BI26, BI27, BI28, BI29, BI30, BI31, BI32, BI33, V1, V2, V3, V4, V5, V6, V7, V8, V9, V10, V11, V12, V13, V14, V15, V16)	----- ----- -----	
Inhibit 37-1 <i>Selects which inputs inhibit the 37-1 element</i>	Combination of (BI1, BI2, BI3, BI4, BI5, BI6, BI7, BI8, BI9, BI10, BI11, BI12, BI13, BI14, BI15, BI16, BI17, BI18, BI19, BI20, BI21, BI22, BI23, BI24, BI25, BI26, BI27, BI28, BI29, BI30, BI31, BI32, BI33, V1, V2, V3, V4, V5, V6, V7, V8, V9, V10, V11, V12, V13, V14, V15, V16)	----- ----- -----	
Inhibit 37-2 <i>Selects which inputs inhibit the 37-2 element</i>	Combination of (BI1, BI2, BI3, BI4, BI5, BI6, BI7, BI8, BI9, BI10, BI11, BI12, BI13, BI14, BI15, BI16, BI17, BI18, BI19, BI20, BI21, BI22, BI23, BI24, BI25, BI26, BI27, BI28, BI29, BI30, BI31, BI32, BI33, V1, V2, V3, V4, V5, V6, V7, V8, V9, V10, V11, V12, V13, V14, V15, V16)	----- ----- -----	

Description	Range	Default	Setting
Inhibit 49 <i>Selects which inputs inhibit the 49 thermal element</i>	Combination of (BI1, BI2, BI3, BI4, BI5, BI6, BI7, BI8, BI9, BI10, BI11, BI12, BI13, BI14, BI15, BI16, BI17, BI18, BI19, BI20, BI21, BI22, BI23, BI24, BI25, BI26, BI27, BI28, BI29, BI30, BI31, BI32, BI33, V1, V2, V3, V4, V5, V6, V7, V8, V9, V10, V11, V12, V13, V14, V15, V16)	----- ----- -----	
Reset 49 <i>Selects which inputs resets the 49 thermal model element</i>	Combination of (BI1, BI2, BI3, BI4, BI5, BI6, BI7, BI8, BI9, BI10, BI11, BI12, BI13, BI14, BI15, BI16, BI17, BI18, BI19, BI20, BI21, BI22, BI23, BI24, BI25, BI26, BI27, BI28, BI29, BI30, BI31, BI32, BI33, V1, V2, V3, V4, V5, V6, V7, V8, V9, V10, V11, V12, V13, V14, V15, V16)	----- ----- -----	
Inhibit 27/59-1 <i>Selects which inputs inhibit the 27/59-1 element</i>	Combination of (BI1, BI2, BI3, BI4, BI5, BI6, BI7, BI8, BI9, BI10, BI11, BI12, BI13, BI14, BI15, BI16, BI17, BI18, BI19, BI20, BI21, BI22, BI23, BI24, BI25, BI26, BI27, BI28, BI29, BI30, BI31, BI32, BI33, V1, V2, V3, V4, V5, V6, V7, V8, V9, V10, V11, V12, V13, V14, V15, V16)	----- ----- -----	
Inhibit 27/59-2 <i>Selects which inputs inhibit the 27/59-2 element</i>	Combination of (BI1, BI2, BI3, BI4, BI5, BI6, BI7, BI8, BI9, BI10, BI11, BI12, BI13, BI14, BI15, BI16, BI17, BI18, BI19, BI20, BI21, BI22, BI23, BI24, BI25, BI26, BI27, BI28, BI29, BI30, BI31, BI32, BI33, V1, V2, V3, V4, V5, V6, V7, V8, V9, V10, V11, V12, V13, V14, V15, V16)	----- ----- -----	
Inhibit 27/59-3 <i>Selects which inputs inhibit the 27/59-3 element</i>	Combination of (BI1, BI2, BI3, BI4, BI5, BI6, BI7, BI8, BI9, BI10, BI11, BI12, BI13, BI14, BI15, BI16, BI17, BI18, BI19, BI20, BI21, BI22, BI23, BI24, BI25, BI26, BI27, BI28, BI29, BI30, BI31, BI32, BI33, V1, V2, V3, V4, V5, V6, V7, V8, V9, V10, V11, V12, V13, V14, V15, V16)	----- ----- -----	
Inhibit 27/59-4 <i>Selects which inputs inhibit the 27/59-4 element</i>	Combination of (BI1, BI2, BI3, BI4, BI5, BI6, BI7, BI8, BI9, BI10, BI11, BI12, BI13, BI14, BI15, BI16, BI17, BI18, BI19, BI20, BI21, BI22, BI23, BI24, BI25, BI26, BI27, BI28, BI29, BI30, BI31, BI32, BI33, V1, V2, V3, V4, V5, V6, V7, V8, V9, V10, V11, V12, V13, V14, V15, V16)	----- ----- -----	

Description	Range	Default	Setting
Inhibit Vx 27/59 <i>Selects which inputs inhibit the Vx 27/59 element</i>	Combination of (BI1, BI2, BI3, BI4, BI5, BI6, BI7, BI8, BI9, BI10, BI11, BI12, BI13, BI14, BI15, BI16, BI17, BI18, BI19, BI20, BI21, BI22, BI23, BI24, BI25, BI26, BI27, BI28, BI29, BI30, BI31, BI32, BI33, V1, V2, V3, V4, V5, V6, V7, V8, V9, V10, V11, V12, V13, V14, V15, V16)	----- ----- -----	
Inhibit 47-1 <i>Selects which inputs inhibit the 47-1 element</i>	Combination of (BI1, BI2, BI3, BI4, BI5, BI6, BI7, BI8, BI9, BI10, BI11, BI12, BI13, BI14, BI15, BI16, BI17, BI18, BI19, BI20, BI21, BI22, BI23, BI24, BI25, BI26, BI27, BI28, BI29, BI30, BI31, BI32, BI33, V1, V2, V3, V4, V5, V6, V7, V8, V9, V10, V11, V12, V13, V14, V15, V16)	----- ----- -----	
Inhibit 47-2 <i>Selects which inputs inhibit the 47-2 element</i>	Combination of (BI1, BI2, BI3, BI4, BI5, BI6, BI7, BI8, BI9, BI10, BI11, BI12, BI13, BI14, BI15, BI16, BI17, BI18, BI19, BI20, BI21, BI22, BI23, BI24, BI25, BI26, BI27, BI28, BI29, BI30, BI31, BI32, BI33, V1, V2, V3, V4, V5, V6, V7, V8, V9, V10, V11, V12, V13, V14, V15, V16)	----- ----- -----	
Inhibit 59NIT <i>Selects which inputs inhibit the 59N IDMTL/DTL element</i>	Combination of (BI1, BI2, BI3, BI4, BI5, BI6, BI7, BI8, BI9, BI10, BI11, BI12, BI13, BI14, BI15, BI16, BI17, BI18, BI19, BI20, BI21, BI22, BI23, BI24, BI25, BI26, BI27, BI28, BI29, BI30, BI31, BI32, BI33, V1, V2, V3, V4, V5, V6, V7, V8, V9, V10, V11, V12, V13, V14, V15, V16)	----- ----- -----	
Inhibit 59NDT <i>Selects which inputs inhibit the 59N INST/DTL element</i>	Combination of (BI1, BI2, BI3, BI4, BI5, BI6, BI7, BI8, BI9, BI10, BI11, BI12, BI13, BI14, BI15, BI16, BI17, BI18, BI19, BI20, BI21, BI22, BI23, BI24, BI25, BI26, BI27, BI28, BI29, BI30, BI31, BI32, BI33, V1, V2, V3, V4, V5, V6, V7, V8, V9, V10, V11, V12, V13, V14, V15, V16)	----- ----- -----	
Inhibit 81-1 <i>Selects which inputs inhibit the 81-1 element</i>	Combination of (BI1, BI2, BI3, BI4, BI5, BI6, BI7, BI8, BI9, BI10, BI11, BI12, BI13, BI14, BI15, BI16, BI17, BI18, BI19, BI20, BI21, BI22, BI23, BI24, BI25, BI26, BI27, BI28, BI29, BI30, BI31, BI32, BI33, V1, V2, V3, V4, V5, V6, V7, V8, V9, V10, V11, V12, V13, V14, V15, V16)	----- ----- -----	

Description	Range	Default	Setting
Inhibit 81-2 <i>Selects which inputs inhibit the 81-2 element</i>	Combination of (BI1, BI2, BI3, BI4, BI5, BI6, BI7, BI8, BI9, BI10, BI11, BI12, BI13, BI14, BI15, BI16, BI17, BI18, BI19, BI20, BI21, BI22, BI23, BI24, BI25, BI26, BI27, BI28, BI29, BI30, BI31, BI32, BI33, V1, V2, V3, V4, V5, V6, V7, V8, V9, V10, V11, V12, V13, V14, V15, V16)	----- ----- -----	
Inhibit 81-3 <i>Selects which inputs inhibit the 81-3 element</i>	Combination of (BI1, BI2, BI3, BI4, BI5, BI6, BI7, BI8, BI9, BI10, BI11, BI12, BI13, BI14, BI15, BI16, BI17, BI18, BI19, BI20, BI21, BI22, BI23, BI24, BI25, BI26, BI27, BI28, BI29, BI30, BI31, BI32, BI33, V1, V2, V3, V4, V5, V6, V7, V8, V9, V10, V11, V12, V13, V14, V15, V16)	----- ----- -----	
Inhibit 81-4 <i>Selects which inputs inhibit the 81-4 element</i>	Combination of (BI1, BI2, BI3, BI4, BI5, BI6, BI7, BI8, BI9, BI10, BI11, BI12, BI13, BI14, BI15, BI16, BI17, BI18, BI19, BI20, BI21, BI22, BI23, BI24, BI25, BI26, BI27, BI28, BI29, BI30, BI31, BI32, BI33, V1, V2, V3, V4, V5, V6, V7, V8, V9, V10, V11, V12, V13, V14, V15, V16)	----- ----- -----	
Inhibit 60CTS <i>Selects which inputs inhibit the CT Supervision element</i>	Combination of (BI1, BI2, BI3, BI4, BI5, BI6, BI7, BI8, BI9, BI10, BI11, BI12, BI13, BI14, BI15, BI16, BI17, BI18, BI19, BI20, BI21, BI22, BI23, BI24, BI25, BI26, BI27, BI28, BI29, BI30, BI31, BI32, BI33, V1, V2, V3, V4, V5, V6, V7, V8, V9, V10, V11, V12, V13, V14, V15, V16)	----- ----- -----	
Inhibit 46BC <i>Selects which inputs inhibit the 46 Broken Conductor element</i>	Combination of (BI1, BI2, BI3, BI4, BI5, BI6, BI7, BI8, BI9, BI10, BI11, BI12, BI13, BI14, BI15, BI16, BI17, BI18, BI19, BI20, BI21, BI22, BI23, BI24, BI25, BI26, BI27, BI28, BI29, BI30, BI31, BI32, BI33, V1, V2, V3, V4, V5, V6, V7, V8, V9, V10, V11, V12, V13, V14, V15, V16)	----- ----- -----	
74TCS-1 <i>Selects which inputs are monitoring trip circuits</i>	Combination of (BI1, BI2, BI3, BI4, BI5, BI6, BI7, BI8, BI9, BI10, BI11, BI12, BI13, BI14, BI15, BI16, BI17, BI18, BI19, BI20, BI21, BI22, BI23, BI24, BI25, BI26, BI27, BI28, BI29, BI30, BI31, BI32, BI33, V1, V2, V3, V4, V5, V6, V7, V8, V9, V10, V11, V12, V13, V14, V15, V16)	----- ----- -----	

Description	Range	Default	Setting
74TCS-2 <i>As Above</i>	Combination of (BI1, BI2, BI3, BI4, BI5, BI6, BI7, BI8, BI9, BI10, BI11, BI12, BI13, BI14, BI15, BI16, BI17, BI18, BI19, BI20, BI21, BI22, BI23, BI24, BI25, BI26, BI27, BI28, BI29, BI30, BI31, BI32, BI33, V1, V2, V3, V4, V5, V6, V7, V8, V9, V10, V11, V12, V13, V14, V15, V16)	----- ----- -----	
74TCS-3 <i>As Above</i>	Combination of (BI1, BI2, BI3, BI4, BI5, BI6, BI7, BI8, BI9, BI10, BI11, BI12, BI13, BI14, BI15, BI16, BI17, BI18, BI19, BI20, BI21, BI22, BI23, BI24, BI25, BI26, BI27, BI28, BI29, BI30, BI31, BI32, BI33, V1, V2, V3, V4, V5, V6, V7, V8, V9, V10, V11, V12, V13, V14, V15, V16)	----- ----- -----	
Trig Trip Contacts <i>Selects which inputs will trigger the Trip contacts</i>	Combination of (BI1, BI2, BI3, BI4, BI5, BI6, BI7, BI8, BI9, BI10, BI11, BI12, BI13, BI14, BI15, BI16, BI17, BI18, BI19, BI20, BI21, BI22, BI23, BI24, BI25, BI26, BI27, BI28, BI29, BI30, BI31, BI32, BI33, V1, V2, V3, V4, V5, V6, V7, V8, V9, V10, V11, V12, V13, V14, V15, V16)	----- ----- -----	
Inhibit 50BF <i>Selects which inputs inhibit the 50BF element</i>	Combination of (BI1, BI2, BI3, BI4, BI5, BI6, BI7, BI8, BI9, BI10, BI11, BI12, BI13, BI14, BI15, BI16, BI17, BI18, BI19, BI20, BI21, BI22, BI23, BI24, BI25, BI26, BI27, BI28, BI29, BI30, BI31, BI32, BI33, V1, V2, V3, V4, V5, V6, V7, V8, V9, V10, V11, V12, V13, V14, V15, V16)	----- ----- -----	
50BF CB Faulty <i>Selects which input bypasses the 50BF timer due to a fault CB</i>	Combination of (BI1, BI2, BI3, BI4, BI5, BI6, BI7, BI8, BI9, BI10, BI11, BI12, BI13, BI14, BI15, BI16, BI17, BI18, BI19, BI20, BI21, BI22, BI23, BI24, BI25, BI26, BI27, BI28, BI29, BI30, BI31, BI32, BI33, V1, V2, V3, V4, V5, V6, V7, V8, V9, V10, V11, V12, V13, V14, V15, V16)	----- ----- -----	
50BF Mech Trip <i>Selects which input allows a mechanical trip to start the 50BF element</i>	Combination of (BI1, BI2, BI3, BI4, BI5, BI6, BI7, BI8, BI9, BI10, BI11, BI12, BI13, BI14, BI15, BI16, BI17, BI18, BI19, BI20, BI21, BI22, BI23, BI24, BI25, BI26, BI27, BI28, BI29, BI30, BI31, BI32, BI33, V1, V2, V3, V4, V5, V6, V7, V8, V9, V10, V11, V12, V13, V14, V15, V16)	----- ----- -----	

Description	Range	Default	Setting
50BF Ext Trip <i>Selects which inputs can also start the 50BF element</i>	Combination of (BI1, BI2, BI3, BI4, BI5, BI6, BI7, BI8, BI9, BI10, BI11, BI12, BI13, BI14, BI15, BI16, BI17, BI18, BI19, BI20, BI21, BI22, BI23, BI24, BI25, BI26, BI27, BI28, BI29, BI30, BI31, BI32, BI33, V1, V2, V3, V4, V5, V6, V7, V8, V9, V10, V11, V12, V13, V14, V15, V16)	----- ----- -----	
Inhibit 60VTS <i>Selects which inputs inhibit the VT Supervision element</i>	Combination of (BI1, BI2, BI3, BI4, BI5, BI6, BI7, BI8, BI9, BI10, BI11, BI12, BI13, BI14, BI15, BI16, BI17, BI18, BI19, BI20, BI21, BI22, BI23, BI24, BI25, BI26, BI27, BI28, BI29, BI30, BI31, BI32, BI33, V1, V2, V3, V4, V5, V6, V7, V8, V9, V10, V11, V12, V13, V14, V15, V16)	----- ----- -----	
Ext Trig 60VTS <i>Selects MCB inputs to VT Supervision element</i>	Combination of (BI1, BI2, BI3, BI4, BI5, BI6, BI7, BI8, BI9, BI10, BI11, BI12, BI13, BI14, BI15, BI16, BI17, BI18, BI19, BI20, BI21, BI22, BI23, BI24, BI25, BI26, BI27, BI28, BI29, BI30, BI31, BI32, BI33, V1, V2, V3, V4, V5, V6, V7, V8, V9, V10, V11, V12, V13, V14, V15, V16)	----- ----- -----	
Ext Reset 60VTS <i>Selects which inputs reset the VT Supervision element</i>	Combination of (BI1, BI2, BI3, BI4, BI5, BI6, BI7, BI8, BI9, BI10, BI11, BI12, BI13, BI14, BI15, BI16, BI17, BI18, BI19, BI20, BI21, BI22, BI23, BI24, BI25, BI26, BI27, BI28, BI29, BI30, BI31, BI32, BI33, V1, V2, V3, V4, V5, V6, V7, V8, V9, V10, V11, V12, V13, V14, V15, V16)	----- ----- -----	
Inhibit 60VTF-Bus <i>Selects which inputs inhibit the VT Fail element on the Bus VTs</i>	Combination of (BI1, BI2, BI3, BI4, BI5, BI6, BI7, BI8, BI9, BI10, BI11, BI12, BI13, BI14, BI15, BI16, BI17, BI18, BI19, BI20, BI21, BI22, BI23, BI24, BI25, BI26, BI27, BI28, BI29, BI30, BI31, BI32, BI33, V1, V2, V3, V4, V5, V6, V7, V8, V9, V10, V11, V12, V13, V14, V15, V16)	----- ----- -----	
Reset CB Total Trip <i>Selects which inputs Reset the CB Total Trip count</i>	Combination of (BI1, BI2, BI3, BI4, BI5, BI6, BI7, BI8, BI9, BI10, BI11, BI12, BI13, BI14, BI15, BI16, BI17, BI18, BI19, BI20, BI21, BI22, BI23, BI24, BI25, BI26, BI27, BI28, BI29, BI30, BI31, BI32, BI33, V1, V2, V3, V4, V5, V6, V7, V8, V9, V10, V11, V12, V13, V14, V15, V16)	----- ----- -----	

Description	Range	Default	Setting
Reset CB Delta Trip <i>Selects which inputs Reset the CB Delta Trip count</i>	Combination of (BI1, BI2, BI3, BI4, BI5, BI6, BI7, BI8, BI9, BI10, BI11, BI12, BI13, BI14, BI15, BI16, BI17, BI18, BI19, BI20, BI21, BI22, BI23, BI24, BI25, BI26, BI27, BI28, BI29, BI30, BI31, BI32, BI33, V1, V2, V3, V4, V5, V6, V7, V8, V9, V10, V11, V12, V13, V14, V15, V16)	----- ----- -----	
Reset ARBlock Count <i>Selects which inputs Reset the AR Block count</i>	Combination of (BI1, BI2, BI3, BI4, BI5, BI6, BI7, BI8, BI9, BI10, BI11, BI12, BI13, BI14, BI15, BI16, BI17, BI18, BI19, BI20, BI21, BI22, BI23, BI24, BI25, BI26, BI27, BI28, BI29, BI30, BI31, BI32, BI33, V1, V2, V3, V4, V5, V6, V7, V8, V9, V10, V11, V12, V13, V14, V15, V16)	----- ----- -----	
Reset Freq Ops Count <i>Selects which inputs Reset the Frequent Ops count</i>	Combination of (BI1, BI2, BI3, BI4, BI5, BI6, BI7, BI8, BI9, BI10, BI11, BI12, BI13, BI14, BI15, BI16, BI17, BI18, BI19, BI20, BI21, BI22, BI23, BI24, BI25, BI26, BI27, BI28, BI29, BI30, BI31, BI32, BI33, V1, V2, V3, V4, V5, V6, V7, V8, V9, V10, V11, V12, V13, V14, V15, V16)	----- ----- -----	
Reset CB LO Count <i>Selects which inputs Reset the CB Lockout operations count</i>	Combination of (BI1, BI2, BI3, BI4, BI5, BI6, BI7, BI8, BI9, BI10, BI11, BI12, BI13, BI14, BI15, BI16, BI17, BI18, BI19, BI20, BI21, BI22, BI23, BI24, BI25, BI26, BI27, BI28, BI29, BI30, BI31, BI32, BI33, V1, V2, V3, V4, V5, V6, V7, V8, V9, V10, V11, V12, V13, V14, V15, V16)	----- ----- -----	
Reset I ^Δ 2t CB Wear <i>Selects which inputs Reset the I^Δ2t CB Wear element</i>	Combination of (BI1, BI2, BI3, BI4, BI5, BI6, BI7, BI8, BI9, BI10, BI11, BI12, BI13, BI14, BI15, BI16, BI17, BI18, BI19, BI20, BI21, BI22, BI23, BI24, BI25, BI26, BI27, BI28, BI29, BI30, BI31, BI32, BI33, V1, V2, V3, V4, V5, V6, V7, V8, V9, V10, V11, V12, V13, V14, V15, V16)	----- ----- -----	
Trigger I ^Δ 2t CB Wear <i>Selects which inputs will cause an external trigger of the I^Δ2t CB Wear element</i>	Combination of (BI1, BI2, BI3, BI4, BI5, BI6, BI7, BI8, BI9, BI10, BI11, BI12, BI13, BI14, BI15, BI16, BI17, BI18, BI19, BI20, BI21, BI22, BI23, BI24, BI25, BI26, BI27, BI28, BI29, BI30, BI31, BI32, BI33, V1, V2, V3, V4, V5, V6, V7, V8, V9, V10, V11, V12, V13, V14, V15, V16)	----- ----- -----	

Description	Range	Default	Setting
General Alarm 1 <i>Selects which inputs will activate the General Alarm 1 text</i>	Combination of (BI1, BI2, BI3, BI4, BI5, BI6, BI7, BI8, BI9, BI10, BI11, BI12, BI13, BI14, BI15, BI16, BI17, BI18, BI19, BI20, BI21, BI22, BI23, BI24, BI25, BI26, BI27, BI28, BI29, BI30, BI31, BI32, BI33, V1, V2, V3, V4, V5, V6, V7, V8, V9, V10, V11, V12, V13, V14, V15, V16)	----- ----- -----	
General Alarm 2 <i>Selects which inputs will activate the General Alarm 2 text</i>	Combination of (BI1, BI2, BI3, BI4, BI5, BI6, BI7, BI8, BI9, BI10, BI11, BI12, BI13, BI14, BI15, BI16, BI17, BI18, BI19, BI20, BI21, BI22, BI23, BI24, BI25, BI26, BI27, BI28, BI29, BI30, BI31, BI32, BI33, V1, V2, V3, V4, V5, V6, V7, V8, V9, V10, V11, V12, V13, V14, V15, V16)	----- ----- -----	
General Alarm 3 <i>Selects which inputs will activate the General Alarm 3 text</i>	Combination of (BI1, BI2, BI3, BI4, BI5, BI6, BI7, BI8, BI9, BI10, BI11, BI12, BI13, BI14, BI15, BI16, BI17, BI18, BI19, BI20, BI21, BI22, BI23, BI24, BI25, BI26, BI27, BI28, BI29, BI30, BI31, BI32, BI33, V1, V2, V3, V4, V5, V6, V7, V8, V9, V10, V11, V12, V13, V14, V15, V16)	----- ----- -----	
General Alarm 4 <i>Selects which inputs will activate the General Alarm 4 text</i>	Combination of (BI1, BI2, BI3, BI4, BI5, BI6, BI7, BI8, BI9, BI10, BI11, BI12, BI13, BI14, BI15, BI16, BI17, BI18, BI19, BI20, BI21, BI22, BI23, BI24, BI25, BI26, BI27, BI28, BI29, BI30, BI31, BI32, BI33, V1, V2, V3, V4, V5, V6, V7, V8, V9, V10, V11, V12, V13, V14, V15, V16)	----- ----- -----	
General Alarm 5 <i>Selects which inputs will activate the General Alarm 5 text</i>	Combination of (BI1, BI2, BI3, BI4, BI5, BI6, BI7, BI8, BI9, BI10, BI11, BI12, BI13, BI14, BI15, BI16, BI17, BI18, BI19, BI20, BI21, BI22, BI23, BI24, BI25, BI26, BI27, BI28, BI29, BI30, BI31, BI32, BI33, V1, V2, V3, V4, V5, V6, V7, V8, V9, V10, V11, V12, V13, V14, V15, V16)	----- ----- -----	
General Alarm 6 <i>Selects which inputs will activate the General Alarm 6 text</i>	Combination of (BI1, BI2, BI3, BI4, BI5, BI6, BI7, BI8, BI9, BI10, BI11, BI12, BI13, BI14, BI15, BI16, BI17, BI18, BI19, BI20, BI21, BI22, BI23, BI24, BI25, BI26, BI27, BI28, BI29, BI30, BI31, BI32, BI33, V1, V2, V3, V4, V5, V6, V7, V8, V9, V10, V11, V12, V13, V14, V15, V16)	----- ----- -----	

Description	Range	Default	Setting
General Alarm 7 <i>Selects which inputs will activate the General Alarm 7 text</i>	Combination of (BI1, BI2, BI3, BI4, BI5, BI6, BI7, BI8, BI9, BI10, BI11, BI12, BI13, BI14, BI15, BI16, BI17, BI18, BI19, BI20, BI21, BI22, BI23, BI24, BI25, BI26, BI27, BI28, BI29, BI30, BI31, BI32, BI33, V1, V2, V3, V4, V5, V6, V7, V8, V9, V10, V11, V12, V13, V14, V15, V16)	----- ----- -----	
General Alarm 8 <i>Selects which inputs will activate the General Alarm 8 text</i>	Combination of (BI1, BI2, BI3, BI4, BI5, BI6, BI7, BI8, BI9, BI10, BI11, BI12, BI13, BI14, BI15, BI16, BI17, BI18, BI19, BI20, BI21, BI22, BI23, BI24, BI25, BI26, BI27, BI28, BI29, BI30, BI31, BI32, BI33, V1, V2, V3, V4, V5, V6, V7, V8, V9, V10, V11, V12, V13, V14, V15, V16)	----- ----- -----	
General Alarm 9 <i>Selects which inputs will activate the General Alarm 9 text</i>	Combination of (BI1, BI2, BI3, BI4, BI5, BI6, BI7, BI8, BI9, BI10, BI11, BI12, BI13, BI14, BI15, BI16, BI17, BI18, BI19, BI20, BI21, BI22, BI23, BI24, BI25, BI26, BI27, BI28, BI29, BI30, BI31, BI32, BI33, V1, V2, V3, V4, V5, V6, V7, V8, V9, V10, V11, V12, V13, V14, V15, V16)	----- ----- -----	
General Alarm 10 <i>Selects which inputs will activate the General Alarm 10 text</i>	Combination of (BI1, BI2, BI3, BI4, BI5, BI6, BI7, BI8, BI9, BI10, BI11, BI12, BI13, BI14, BI15, BI16, BI17, BI18, BI19, BI20, BI21, BI22, BI23, BI24, BI25, BI26, BI27, BI28, BI29, BI30, BI31, BI32, BI33, V1, V2, V3, V4, V5, V6, V7, V8, V9, V10, V11, V12, V13, V14, V15, V16)	----- ----- -----	
General Alarm 11 <i>Selects which inputs will activate the General Alarm 11 text</i>	Combination of (BI1, BI2, BI3, BI4, BI5, BI6, BI7, BI8, BI9, BI10, BI11, BI12, BI13, BI14, BI15, BI16, BI17, BI18, BI19, BI20, BI21, BI22, BI23, BI24, BI25, BI26, BI27, BI28, BI29, BI30, BI31, BI32, BI33, V1, V2, V3, V4, V5, V6, V7, V8, V9, V10, V11, V12, V13, V14, V15, V16)	----- ----- -----	
General Alarm 12 <i>Selects which inputs will activate the General Alarm 12 text</i>	Combination of (BI1, BI2, BI3, BI4, BI5, BI6, BI7, BI8, BI9, BI10, BI11, BI12, BI13, BI14, BI15, BI16, BI17, BI18, BI19, BI20, BI21, BI22, BI23, BI24, BI25, BI26, BI27, BI28, BI29, BI30, BI31, BI32, BI33, V1, V2, V3, V4, V5, V6, V7, V8, V9, V10, V11, V12, V13, V14, V15, V16)	----- ----- -----	

Description	Range	Default	Setting
BatteryTestRequired <i>Selects which inputs will initiate a Battery test</i>	Combination of (BI1, BI2, BI3, BI4, BI5, BI6, BI7, BI8, BI9, BI10, BI11, BI12, BI13, BI14, BI15, BI16, BI17, BI18, BI19, BI20, BI21, BI22, BI23, BI24, BI25, BI26, BI27, BI28, BI29, BI30, BI31, BI32, BI33, V1, V2, V3, V4, V5, V6, V7, V8, V9, V10, V11, V12, V13, V14, V15, V16)	----- ----- -----	
ExtPowerGood <i>Selects which inputs are used to indicate External power to battery is good.</i>	Combination of (BI1, BI2, BI3, BI4, BI5, BI6, BI7, BI8, BI9, BI10, BI11, BI12, BI13, BI14, BI15, BI16, BI17, BI18, BI19, BI20, BI21, BI22, BI23, BI24, BI25, BI26, BI27, BI28, BI29, BI30, BI31, BI32, BI33, V1, V2, V3, V4, V5, V6, V7, V8, V9, V10, V11, V12, V13, V14, V15, V16)	----- ----- -----	
InhibitBatteryTest <i>Selects which inputs will inhibit a Battery test.</i>	Combination of (BI1, BI2, BI3, BI4, BI5, BI6, BI7, BI8, BI9, BI10, BI11, BI12, BI13, BI14, BI15, BI16, BI17, BI18, BI19, BI20, BI21, BI22, BI23, BI24, BI25, BI26, BI27, BI28, BI29, BI30, BI31, BI32, BI33, V1, V2, V3, V4, V5, V6, V7, V8, V9, V10, V11, V12, V13, V14, V15, V16)	----- ----- -----	
CapMon Input 1 <i>Selects which inputs will monitor Capacitor level 1.</i>	Combination of (BI1, BI2, BI3, BI4, BI5, BI6, BI7, BI8, BI9, BI10, BI11, BI12, BI13, BI14, BI15, BI16, BI17, BI18, BI19, BI20, BI21, BI22, BI23, BI24, BI25, BI26, BI27, BI28, BI29, BI30, BI31, BI32, BI33, V1, V2, V3, V4, V5, V6, V7, V8, V9, V10, V11, V12, V13, V14, V15, V16)	----- ----- -----	
CapMon Input 2 <i>Selects which inputs will monitor Capacitor level 2.</i>	Combination of (BI1, BI2, BI3, BI4, BI5, BI6, BI7, BI8, BI9, BI10, BI11, BI12, BI13, BI14, BI15, BI16, BI17, BI18, BI19, BI20, BI21, BI22, BI23, BI24, BI25, BI26, BI27, BI28, BI29, BI30, BI31, BI32, BI33, V1, V2, V3, V4, V5, V6, V7, V8, V9, V10, V11, V12, V13, V14, V15, V16)	----- ----- -----	
Capacitor Test <i>Selects which inputs will initiate a Capacitor test.</i>	Combination of (BI1, BI2, BI3, BI4, BI5, BI6, BI7, BI8, BI9, BI10, BI11, BI12, BI13, BI14, BI15, BI16, BI17, BI18, BI19, BI20, BI21, BI22, BI23, BI24, BI25, BI26, BI27, BI28, BI29, BI30, BI31, BI32, BI33, V1, V2, V3, V4, V5, V6, V7, V8, V9, V10, V11, V12, V13, V14, V15, V16)	----- ----- -----	

Description	Range	Default	Setting
Inhibit Cap Test <i>Selects which inputs will inhibit a Capacitor test.</i>	Combination of (BI1, BI2, BI3, BI4, BI5, BI6, BI7, BI8, BI9, BI10, BI11, BI12, BI13, BI14, BI15, BI16, BI17, BI18, BI19, BI20, BI21, BI22, BI23, BI24, BI25, BI26, BI27, BI28, BI29, BI30, BI31, BI32, BI33, V1, V2, V3, V4, V5, V6, V7, V8, V9, V10, V11, V12, V13, V14, V15, V16)	----- ----- -----	
Reset SagSwell Count <i>Selects which inputs will reset the 27Sag & 59Swell counts.</i>	Combination of (BI1, BI2, BI3, BI4, BI5, BI6, BI7, BI8, BI9, BI10, BI11, BI12, BI13, BI14, BI15, BI16, BI17, BI18, BI19, BI20, BI21, BI22, BI23, BI24, BI25, BI26, BI27, BI28, BI29, BI30, BI31, BI32, BI33, V1, V2, V3, V4, V5, V6, V7, V8, V9, V10, V11, V12, V13, V14, V15, V16)	----- ----- -----	
Inhibit 27Sag <i>Selects which inputs will inhibit the 27Sag elements.</i>	Combination of (BI1, BI2, BI3, BI4, BI5, BI6, BI7, BI8, BI9, BI10, BI11, BI12, BI13, BI14, BI15, BI16, BI17, BI18, BI19, BI20, BI21, BI22, BI23, BI24, BI25, BI26, BI27, BI28, BI29, BI30, BI31, BI32, BI33, V1, V2, V3, V4, V5, V6, V7, V8, V9, V10, V11, V12, V13, V14, V15, V16)	----- ----- -----	
Inhibit 59Swell <i>Selects which inputs will inhibit the 59Swell elements.</i>	Combination of (BI1, BI2, BI3, BI4, BI5, BI6, BI7, BI8, BI9, BI10, BI11, BI12, BI13, BI14, BI15, BI16, BI17, BI18, BI19, BI20, BI21, BI22, BI23, BI24, BI25, BI26, BI27, BI28, BI29, BI30, BI31, BI32, BI33, V1, V2, V3, V4, V5, V6, V7, V8, V9, V10, V11, V12, V13, V14, V15, V16)	----- ----- -----	
Reset Demand <i>Selects which inputs will rest the Demand elements.</i>	Combination of (BI1, BI2, BI3, BI4, BI5, BI6, BI7, BI8, BI9, BI10, BI11, BI12, BI13, BI14, BI15, BI16, BI17, BI18, BI19, BI20, BI21, BI22, BI23, BI24, BI25, BI26, BI27, BI28, BI29, BI30, BI31, BI32, BI33, V1, V2, V3, V4, V5, V6, V7, V8, V9, V10, V11, V12, V13, V14, V15, V16)	----- ----- -----	
Close CB <i>Selects which inputs will issue a close to the circuit breaker.</i>	Combination of (BI1, BI2, BI3, BI4, BI5, BI6, BI7, BI8, BI9, BI10, BI11, BI12, BI13, BI14, BI15, BI16, BI17, BI18, BI19, BI20, BI21, BI22, BI23, BI24, BI25, BI26, BI27, BI28, BI29, BI30, BI31, BI32, BI33, V1, V2, V3, V4, V5, V6, V7, V8, V9, V10, V11, V12, V13, V14, V15, V16)	----- ----- -----	

Description	Range	Default	Setting
Block Close CB <i>Selects which inputs will block the manual closing of the circuit breaker.</i>	Combination of (BI1, BI2, BI3, BI4, BI5, BI6, BI7, BI8, BI9, BI10, BI11, BI12, BI13, BI14, BI15, BI16, BI17, BI18, BI19, BI20, BI21, BI22, BI23, BI24, BI25, BI26, BI27, BI28, BI29, BI30, BI31, BI32, BI33, V1, V2, V3, V4, V5, V6, V7, V8, V9, V10, V11, V12, V13, V14, V15, V16)	----- ----- -----	
Open CB <i>Selects which inputs will issue an open to the circuit breaker.</i>	Combination of (BI1, BI2, BI3, BI4, BI5, BI6, BI7, BI8, BI9, BI10, BI11, BI12, BI13, BI14, BI15, BI16, BI17, BI18, BI19, BI20, BI21, BI22, BI23, BI24, BI25, BI26, BI27, BI28, BI29, BI30, BI31, BI32, BI33, V1, V2, V3, V4, V5, V6, V7, V8, V9, V10, V11, V12, V13, V14, V15, V16)	----- ----- -----	
CB Closed <i>Selects which inputs are connected to the circuit breaker closed contacts</i>	Combination of (BI1, BI2, BI3, BI4, BI5, BI6, BI7, BI8, BI9, BI10, BI11, BI12, BI13, BI14, BI15, BI16, BI17, BI18, BI19, BI20, BI21, BI22, BI23, BI24, BI25, BI26, BI27, BI28, BI29, BI30, BI31, BI32, BI33, V1, V2, V3, V4, V5, V6, V7, V8, V9, V10, V11, V12, V13, V14, V15, V16)	----- ----- -----	
CB Open <i>Selects which inputs are connected to the circuit breaker open contacts</i>	Combination of (BI1, BI2, BI3, BI4, BI5, BI6, BI7, BI8, BI9, BI10, BI11, BI12, BI13, BI14, BI15, BI16, BI17, BI18, BI19, BI20, BI21, BI22, BI23, BI24, BI25, BI26, BI27, BI28, BI29, BI30, BI31, BI32, BI33, V1, V2, V3, V4, V5, V6, V7, V8, V9, V10, V11, V12, V13, V14, V15, V16)	----- ----- -----	
79 Out <i>Selects which inputs will switch the Auto-recloser out of service</i>	Combination of (BI1, BI2, BI3, BI4, BI5, BI6, BI7, BI8, BI9, BI10, BI11, BI12, BI13, BI14, BI15, BI16, BI17, BI18, BI19, BI20, BI21, BI22, BI23, BI24, BI25, BI26, BI27, BI28, BI29, BI30, BI31, BI32, BI33, V1, V2, V3, V4, V5, V6, V7, V8, V9, V10, V11, V12, V13, V14, V15, V16)	----- ----- -----	
79 In <i>Selects which inputs will switch the Auto-recloser in service</i>	Combination of (BI1, BI2, BI3, BI4, BI5, BI6, BI7, BI8, BI9, BI10, BI11, BI12, BI13, BI14, BI15, BI16, BI17, BI18, BI19, BI20, BI21, BI22, BI23, BI24, BI25, BI26, BI27, BI28, BI29, BI30, BI31, BI32, BI33, V1, V2, V3, V4, V5, V6, V7, V8, V9, V10, V11, V12, V13, V14, V15, V16)	----- ----- -----	

Description	Range	Default	Setting
<p>79 Trip & Reclose <i>Selects which inputs will trigger a trip & reclose</i></p>	<p>Combination of (BI1, BI2, BI3, BI4, BI5, BI6, BI7, BI8, BI9, BI10, BI11, BI12, BI13, BI14, BI15, BI16, BI17, BI18, BI19, BI20, BI21, BI22, BI23, BI24, BI25, BI26, BI27, BI28, BI29, BI30, BI31, BI32, BI33, V1, V2, V3, V4, V5, V6, V7, V8, V9, V10, V11, V12, V13, V14, V15, V16)</p>	<p>----- ----- -----</p>	
<p>79 Trip & Lockout <i>Selects which inputs will trigger a trip & lockout</i></p>	<p>Combination of (BI1, BI2, BI3, BI4, BI5, BI6, BI7, BI8, BI9, BI10, BI11, BI12, BI13, BI14, BI15, BI16, BI17, BI18, BI19, BI20, BI21, BI22, BI23, BI24, BI25, BI26, BI27, BI28, BI29, BI30, BI31, BI32, BI33, V1, V2, V3, V4, V5, V6, V7, V8, V9, V10, V11, V12, V13, V14, V15, V16)</p>	<p>----- ----- -----</p>	
<p>79 Ext Trip <i>Selects which input will start the external an Auto-reclose sequence</i></p>	<p>Combination of (BI1, BI2, BI3, BI4, BI5, BI6, BI7, BI8, BI9, BI10, BI11, BI12, BI13, BI14, BI15, BI16, BI17, BI18, BI19, BI20, BI21, BI22, BI23, BI24, BI25, BI26, BI27, BI28, BI29, BI30, BI31, BI32, BI33, V1, V2, V3, V4, V5, V6, V7, V8, V9, V10, V11, V12, V13, V14, V15, V16)</p>	<p>----- ----- -----</p>	
<p>79 Ext Pickup <i>Selects which input should be connected to the pickup of the external elements required to start an Auto-reclose sequence</i></p>	<p>Combination of (BI1, BI2, BI3, BI4, BI5, BI6, BI7, BI8, BI9, BI10, BI11, BI12, BI13, BI14, BI15, BI16, BI17, BI18, BI19, BI20, BI21, BI22, BI23, BI24, BI25, BI26, BI27, BI28, BI29, BI30, BI31, BI32, BI33, V1, V2, V3, V4, V5, V6, V7, V8, V9, V10, V11, V12, V13, V14, V15, V16)</p>	<p>----- ----- -----</p>	
<p>79 Block Reclose <i>Selects which inputs will block the Auto-recloser</i></p>	<p>Combination of (BI1, BI2, BI3, BI4, BI5, BI6, BI7, BI8, BI9, BI10, BI11, BI12, BI13, BI14, BI15, BI16, BI17, BI18, BI19, BI20, BI21, BI22, BI23, BI24, BI25, BI26, BI27, BI28, BI29, BI30, BI31, BI32, BI33, V1, V2, V3, V4, V5, V6, V7, V8, V9, V10, V11, V12, V13, V14, V15, V16)</p>	<p>----- ----- -----</p>	
<p>79 Reset Lockout <i>Selects which inputs will force the Auto-recloser into the Lockout state</i></p>	<p>Combination of (BI1, BI2, BI3, BI4, BI5, BI6, BI7, BI8, BI9, BI10, BI11, BI12, BI13, BI14, BI15, BI16, BI17, BI18, BI19, BI20, BI21, BI22, BI23, BI24, BI25, BI26, BI27, BI28, BI29, BI30, BI31, BI32, BI33, V1, V2, V3, V4, V5, V6, V7, V8, V9, V10, V11, V12, V13, V14, V15, V16)</p>	<p>----- ----- -----</p>	

Description	Range	Default	Setting
79 Line Check <i>Selects which inputs will start the Line Check functionality of the Auto-recloser</i>	Combination of (BI1, BI2, BI3, BI4, BI5, BI6, BI7, BI8, BI9, BI10, BI11, BI12, BI13, BI14, BI15, BI16, BI17, BI18, BI19, BI20, BI21, BI22, BI23, BI24, BI25, BI26, BI27, BI28, BI29, BI30, BI31, BI32, BI33, V1, V2, V3, V4, V5, V6, V7, V8, V9, V10, V11, V12, V13, V14, V15, V16)	----- ----- -----	
79 Lockout <i>Selects which inputs will force the Auto-recloser into the Lockout state</i>	Combination of (BI1, BI2, BI3, BI4, BI5, BI6, BI7, BI8, BI9, BI10, BI11, BI12, BI13, BI14, BI15, BI16, BI17, BI18, BI19, BI20, BI21, BI22, BI23, BI24, BI25, BI26, BI27, BI28, BI29, BI30, BI31, BI32, BI33, V1, V2, V3, V4, V5, V6, V7, V8, V9, V10, V11, V12, V13, V14, V15, V16)	----- ----- -----	
79 Override Sync <i>Selects which inputs will bypass the Synchronisation check of the Auto-recloser</i>	Combination of (BI1, BI2, BI3, BI4, BI5, BI6, BI7, BI8, BI9, BI10, BI11, BI12, BI13, BI14, BI15, BI16, BI17, BI18, BI19, BI20, BI21, BI22, BI23, BI24, BI25, BI26, BI27, BI28, BI29, BI30, BI31, BI32, BI33, V1, V2, V3, V4, V5, V6, V7, V8, V9, V10, V11, V12, V13, V14, V15, V16)	----- ----- -----	
Man Override Sync <i>Selects which inputs will bypass the Synchronisation check of the Manual Close</i>	Combination of (BI1, BI2, BI3, BI4, BI5, BI6, BI7, BI8, BI9, BI10, BI11, BI12, BI13, BI14, BI15, BI16, BI17, BI18, BI19, BI20, BI21, BI22, BI23, BI24, BI25, BI26, BI27, BI28, BI29, BI30, BI31, BI32, BI33, V1, V2, V3, V4, V5, V6, V7, V8, V9, V10, V11, V12, V13, V14, V15, V16)	----- ----- -----	
Ext Start 25 Sync <i>Selects which inputs will start the synchronisation window</i>	Combination of (BI1, BI2, BI3, BI4, BI5, BI6, BI7, BI8, BI9, BI10, BI11, BI12, BI13, BI14, BI15, BI16, BI17, BI18, BI19, BI20, BI21, BI22, BI23, BI24, BI25, BI26, BI27, BI28, BI29, BI30, BI31, BI32, BI33, V1, V2, V3, V4, V5, V6, V7, V8, V9, V10, V11, V12, V13, V14, V15, V16)	----- ----- -----	
Reset 25 Sync <i>Selects which inputs will stop the synchronisation window</i>	Combination of (BI1, BI2, BI3, BI4, BI5, BI6, BI7, BI8, BI9, BI10, BI11, BI12, BI13, BI14, BI15, BI16, BI17, BI18, BI19, BI20, BI21, BI22, BI23, BI24, BI25, BI26, BI27, BI28, BI29, BI30, BI31, BI32, BI33, V1, V2, V3, V4, V5, V6, V7, V8, V9, V10, V11, V12, V13, V14, V15, V16)	----- ----- -----	

Description	Range	Default	Setting
Start 25 System Sync <i>Selects which inputs will start the System Sync check</i>	Combination of (BI1, BI2, BI3, BI4, BI5, BI6, BI7, BI8, BI9, BI10, BI11, BI12, BI13, BI14, BI15, BI16, BI17, BI18, BI19, BI20, BI21, BI22, BI23, BI24, BI25, BI26, BI27, BI28, BI29, BI30, BI31, BI32, BI33, V1, V2, V3, V4, V5, V6, V7, V8, V9, V10, V11, V12, V13, V14, V15, V16)	----- ----- -----	
Hot Line Out <i>Selects which inputs will switch out Hot Line Working</i>	Combination of (BI1, BI2, BI3, BI4, BI5, BI6, BI7, BI8, BI9, BI10, BI11, BI12, BI13, BI14, BI15, BI16, BI17, BI18, BI19, BI20, BI21, BI22, BI23, BI24, BI25, BI26, BI27, BI28, BI29, BI30, BI31, BI32, BI33, V1, V2, V3, V4, V5, V6, V7, V8, V9, V10, V11, V12, V13, V14, V15, V16)	----- ----- -----	
Hot Line In <i>Selects which inputs will switch in Hot Line Working</i>	Combination of (BI1, BI2, BI3, BI4, BI5, BI6, BI7, BI8, BI9, BI10, BI11, BI12, BI13, BI14, BI15, BI16, BI17, BI18, BI19, BI20, BI21, BI22, BI23, BI24, BI25, BI26, BI27, BI28, BI29, BI30, BI31, BI32, BI33, V1, V2, V3, V4, V5, V6, V7, V8, V9, V10, V11, V12, V13, V14, V15, V16)	----- ----- -----	
Inst Prot'n Out <i>Selects which inputs will switch out the instantaneous protection elements</i>	Combination of (BI1, BI2, BI3, BI4, BI5, BI6, BI7, BI8, BI9, BI10, BI11, BI12, BI13, BI14, BI15, BI16, BI17, BI18, BI19, BI20, BI21, BI22, BI23, BI24, BI25, BI26, BI27, BI28, BI29, BI30, BI31, BI32, BI33, V1, V2, V3, V4, V5, V6, V7, V8, V9, V10, V11, V12, V13, V14, V15, V16)	----- ----- -----	
Inst Prot'n In <i>Selects which inputs will switch in the instantaneous protection elements</i>	Combination of (BI1, BI2, BI3, BI4, BI5, BI6, BI7, BI8, BI9, BI10, BI11, BI12, BI13, BI14, BI15, BI16, BI17, BI18, BI19, BI20, BI21, BI22, BI23, BI24, BI25, BI26, BI27, BI28, BI29, BI30, BI31, BI32, BI33, V1, V2, V3, V4, V5, V6, V7, V8, V9, V10, V11, V12, V13, V14, V15, V16)	----- ----- -----	
E/F Out <i>Selects which inputs will switch out the E/F protection elements.</i>	Combination of (BI1, BI2, BI3, BI4, BI5, BI6, BI7, BI8, BI9, BI10, BI11, BI12, BI13, BI14, BI15, BI16, BI17, BI18, BI19, BI20, BI21, BI22, BI23, BI24, BI25, BI26, BI27, BI28, BI29, BI30, BI31, BI32, BI33, V1, V2, V3, V4, V5, V6, V7, V8, V9, V10, V11, V12, V13, V14, V15, V16)	----- ----- -----	

Description	Range	Default	Setting
<p>E/F In <i>Selects which inputs will switch in the E/F protection elements.</i></p>	<p>Combination of (BI1, BI2, BI3, BI4, BI5, BI6, BI7, BI8, BI9, BI10, BI11, BI12, BI13, BI14, BI15, BI16, BI17, BI18, BI19, BI20, BI21, BI22, BI23, BI24, BI25, BI26, BI27, BI28, BI29, BI30, BI31, BI32, BI33, V1, V2, V3, V4, V5, V6, V7, V8, V9, V10, V11, V12, V13, V14, V15, V16)</p>	<p>----- ----- -----</p>	
<p>SEF Out <i>Selects which inputs will switch out the SEF protection elements</i></p>	<p>Combination of (BI1, BI2, BI3, BI4, BI5, BI6, BI7, BI8, BI9, BI10, BI11, BI12, BI13, BI14, BI15, BI16, BI17, BI18, BI19, BI20, BI21, BI22, BI23, BI24, BI25, BI26, BI27, BI28, BI29, BI30, BI31, BI32, BI33, V1, V2, V3, V4, V5, V6, V7, V8, V9, V10, V11, V12, V13, V14, V15, V16)</p>	<p>----- ----- -----</p>	
<p>SEF In <i>Selects which inputs will switch in the SEF protection elements</i></p>	<p>Combination of (BI1, BI2, BI3, BI4, BI5, BI6, BI7, BI8, BI9, BI10, BI11, BI12, BI13, BI14, BI15, BI16, BI17, BI18, BI19, BI20, BI21, BI22, BI23, BI24, BI25, BI26, BI27, BI28, BI29, BI30, BI31, BI32, BI33, V1, V2, V3, V4, V5, V6, V7, V8, V9, V10, V11, V12, V13, V14, V15, V16)</p>	<p>----- ----- -----</p>	
<p>Trigger Wave Rec <i>Selects which inputs can trigger a waveform record</i></p>	<p>Combination of (BI1, BI2, BI3, BI4, BI5, BI6, BI7, BI8, BI9, BI10, BI11, BI12, BI13, BI14, BI15, BI16, BI17, BI18, BI19, BI20, BI21, BI22, BI23, BI24, BI25, BI26, BI27, BI28, BI29, BI30, BI31, BI32, BI33, V1, V2, V3, V4, V5, V6, V7, V8, V9, V10, V11, V12, V13, V14, V15, V16)</p>	<p>----- ----- -----</p>	
<p>Trigger Fault Rec <i>Selects which inputs can trigger a fault record</i></p>	<p>Combination of (BI1, BI2, BI3, BI4, BI5, BI6, BI7, BI8, BI9, BI10, BI11, BI12, BI13, BI14, BI15, BI16, BI17, BI18, BI19, BI20, BI21, BI22, BI23, BI24, BI25, BI26, BI27, BI28, BI29, BI30, BI31, BI32, BI33, V1, V2, V3, V4, V5, V6, V7, V8, V9, V10, V11, V12, V13, V14, V15, V16)</p>	<p>----- ----- -----</p>	
<p>Select Group 1 <i>Switches active setting group to group 1</i></p>	<p>Combination of (BI1, BI2, BI3, BI4, BI5, BI6, BI7, BI8, BI9, BI10, BI11, BI12, BI13, BI14, BI15, BI16, BI17, BI18, BI19, BI20, BI21, BI22, BI23, BI24, BI25, BI26, BI27, BI28, BI29, BI30, BI31, BI32, BI33, V1, V2, V3, V4, V5, V6, V7, V8, V9, V10, V11, V12, V13, V14, V15, V16)</p>	<p>----- ----- -----</p>	

Description	Range	Default	Setting
Reset Energy Meters	Combination of (BI1, BI2, BI3, BI4, BI5, BI6, BI7, BI8, BI9, BI10, BI11, BI12, BI13, BI14, BI15, BI16, BI17, BI18, BI19, BI20, BI21, BI22, BI23, BI24, BI25, BI26, BI27, BI28, BI29, BI30, BI31, BI32, BI33, V1, V2, V3, V4, V5, V6, V7, V8, V9, V10, V11, V12, V13, V14, V15, V16)	----- ----- -----	
Select Group 2 <i>Switches active setting group to group 2</i>	Combination of (BI1, BI2, BI3, BI4, BI5, BI6, BI7, BI8, BI9, BI10, BI11, BI12, BI13, BI14, BI15, BI16, BI17, BI18, BI19, BI20, BI21, BI22, BI23, BI24, BI25, BI26, BI27, BI28, BI29, BI30, BI31, BI32, BI33, V1, V2, V3, V4, V5, V6, V7, V8, V9, V10, V11, V12, V13, V14, V15, V16)	----- ----- -----	
Select Group 3 <i>Switches active setting group to group 3</i>	Combination of (BI1, BI2, BI3, BI4, BI5, BI6, BI7, BI8, BI9, BI10, BI11, BI12, BI13, BI14, BI15, BI16, BI17, BI18, BI19, BI20, BI21, BI22, BI23, BI24, BI25, BI26, BI27, BI28, BI29, BI30, BI31, BI32, BI33, V1, V2, V3, V4, V5, V6, V7, V8, V9, V10, V11, V12, V13, V14, V15, V16)	----- ----- -----	
Select Group 4 <i>Switches active setting group to group 4</i>	Combination of (BI1, BI2, BI3, BI4, BI5, BI6, BI7, BI8, BI9, BI10, BI11, BI12, BI13, BI14, BI15, BI16, BI17, BI18, BI19, BI20, BI21, BI22, BI23, BI24, BI25, BI26, BI27, BI28, BI29, BI30, BI31, BI32, BI33, V1, V2, V3, V4, V5, V6, V7, V8, V9, V10, V11, V12, V13, V14, V15, V16)	----- ----- -----	
Select Group 5 <i>Switches active setting group to group 5</i>	Combination of (BI1, BI2, BI3, BI4, BI5, BI6, BI7, BI8, BI9, BI10, BI11, BI12, BI13, BI14, BI15, BI16, BI17, BI18, BI19, BI20, BI21, BI22, BI23, BI24, BI25, BI26, BI27, BI28, BI29, BI30, BI31, BI32, BI33, V1, V2, V3, V4, V5, V6, V7, V8, V9, V10, V11, V12, V13, V14, V15, V16)	----- ----- -----	
Select Group 6 <i>Switches active setting group to group 6</i>	Combination of (BI1, BI2, BI3, BI4, BI5, BI6, BI7, BI8, BI9, BI10, BI11, BI12, BI13, BI14, BI15, BI16, BI17, BI18, BI19, BI20, BI21, BI22, BI23, BI24, BI25, BI26, BI27, BI28, BI29, BI30, BI31, BI32, BI33, V1, V2, V3, V4, V5, V6, V7, V8, V9, V10, V11, V12, V13, V14, V15, V16)	----- ----- -----	

Description	Range	Default	Setting
Select Group 7 <i>Switches active setting group to group 7</i>	Combination of (BI1, BI2, BI3, BI4, BI5, BI6, BI7, BI8, BI9, BI10, BI11, BI12, BI13, BI14, BI15, BI16, BI17, BI18, BI19, BI20, BI21, BI22, BI23, BI24, BI25, BI26, BI27, BI28, BI29, BI30, BI31, BI32, BI33, V1, V2, V3, V4, V5, V6, V7, V8, V9, V10, V11, V12, V13, V14, V15, V16)	----- ----- -----	
Select Group 8 <i>Switches active setting group to group 8</i>	Combination of (BI1, BI2, BI3, BI4, BI5, BI6, BI7, BI8, BI9, BI10, BI11, BI12, BI13, BI14, BI15, BI16, BI17, BI18, BI19, BI20, BI21, BI22, BI23, BI24, BI25, BI26, BI27, BI28, BI29, BI30, BI31, BI32, BI33, V1, V2, V3, V4, V5, V6, V7, V8, V9, V10, V11, V12, V13, V14, V15, V16)	----- ----- -----	
Out Of Service Mode <i>Selects which inputs will put the relay into Out Of Service Mode</i>	Combination of (BI1, BI2, BI3, BI4, BI5, BI6, BI7, BI8, BI9, BI10, BI11, BI12, BI13, BI14, BI15, BI16, BI17, BI18, BI19, BI20, BI21, BI22, BI23, BI24, BI25, BI26, BI27, BI28, BI29, BI30, BI31, BI32, BI33, V1, V2, V3, V4, V5, V6, V7, V8, V9, V10, V11, V12, V13, V14, V15, V16)	----- ----- -----	
Local Mode <i>Selects which inputs will put the relay into Local Mode</i>	Combination of (BI1, BI2, BI3, BI4, BI5, BI6, BI7, BI8, BI9, BI10, BI11, BI12, BI13, BI14, BI15, BI16, BI17, BI18, BI19, BI20, BI21, BI22, BI23, BI24, BI25, BI26, BI27, BI28, BI29, BI30, BI31, BI32, BI33, V1, V2, V3, V4, V5, V6, V7, V8, V9, V10, V11, V12, V13, V14, V15, V16)	----- ----- -----	
Remote Mode <i>Selects which inputs will put the relay into Remote Mode</i>	Combination of (BI1, BI2, BI3, BI4, BI5, BI6, BI7, BI8, BI9, BI10, BI11, BI12, BI13, BI14, BI15, BI16, BI17, BI18, BI19, BI20, BI21, BI22, BI23, BI24, BI25, BI26, BI27, BI28, BI29, BI30, BI31, BI32, BI33, V1, V2, V3, V4, V5, V6, V7, V8, V9, V10, V11, V12, V13, V14, V15, V16)	----- ----- -----	
Local Or Remote Mode <i>Selects which inputs will put the relay into Local Or Remote Mode</i>	Combination of (BI1, BI2, BI3, BI4, BI5, BI6, BI7, BI8, BI9, BI10, BI11, BI12, BI13, BI14, BI15, BI16, BI17, BI18, BI19, BI20, BI21, BI22, BI23, BI24, BI25, BI26, BI27, BI28, BI29, BI30, BI31, BI32, BI33, V1, V2, V3, V4, V5, V6, V7, V8, V9, V10, V11, V12, V13, V14, V15, V16)	----- ----- -----	

Description	Range	Default	Setting
Clock Sync. <i>Selects which input is used to synchronise the real time clock</i>	Combination of (BI1, BI2, BI3, BI4, BI5, BI6, BI7, BI8, BI9, BI10, BI11, BI12, BI13, BI14, BI15, BI16, BI17, BI18, BI19, BI20, BI21, BI22, BI23, BI24, BI25, BI26, BI27, BI28, BI29, BI30, BI31, BI32, BI33, V1, V2, V3, V4, V5, V6, V7, V8, V9, V10, V11, V12, V13, V14, V15, V16)	----- ----- -----	
Reset LEDs & O/Ps <i>Selects which inputs will reset the latched LEDs and binary outputs</i>	Combination of (BI1, BI2, BI3, BI4, BI5, BI6, BI7, BI8, BI9, BI10, BI11, BI12, BI13, BI14, BI15, BI16, BI17, BI18, BI19, BI20, BI21, BI22, BI23, BI24, BI25, BI26, BI27, BI28, BI29, BI30, BI31, BI32, BI33, V1, V2, V3, V4, V5, V6, V7, V8, V9, V10, V11, V12, V13, V14, V15, V16)	----- ----- -----	

3.8.2. Function Key Matrix

Description	Range	Default	Setting
Open CB <i>Selects which function key will Open the circuit breaker</i>	Combination of (1, 2, 3, 4, 5, 6, 7, 8, 9, 10, 11, 12)	-----	
Close CB <i>Selects which function key will Close the circuit breaker</i>	Combination of (1, 2, 3, 4, 5, 6, 7, 8, 9, 10, 11, 12)	-----	
79 In/Out <i>Selects which function key will toggle Autoreclose In & Out</i>	Combination of (1, 2, 3, 4, 5, 6, 7, 8, 9, 10, 11, 12)	-----	
79 Trip & Reclose <i>Selects which function key will cause the CB to trip & reclose</i>	Combination of (1, 2, 3, 4, 5, 6, 7, 8, 9, 10, 11, 12)	-----	
79 Trip & Lockout <i>Selects which function key will cause the CB to trip & lockout</i>	Combination of (1, 2, 3, 4, 5, 6, 7, 8, 9, 10, 11, 12)	-----	
Hot Line Work In/Out <i>Selects which function key will toggle Hot Line Working In & Out</i>	Combination of (1, 2, 3, 4, 5, 6, 7, 8, 9, 10, 11, 12)	-----	
E/F In/Out <i>Selects which function key will toggle E/F protection In & Out</i>	Combination of (1, 2, 3, 4, 5, 6, 7, 8, 9, 10, 11, 12)	-----	
SEF In/Out <i>Selects which function key will toggle SEF protection In & Out</i>	Combination of (1, 2, 3, 4, 5, 6, 7, 8, 9, 10, 11, 12)	-----	
Inst Prot'n In/Out <i>Selects which function key will toggle Instantaneous protection elements In & Out</i>	Combination of (1, 2, 3, 4, 5, 6, 7, 8, 9, 10, 11, 12)	-----	
Out Of Service Mode <i>Selects which function key will put the relay into Out Of Service Mode</i>	Combination of (1, 2, 3, 4, 5, 6, 7, 8, 9, 10, 11, 12)	-----	

Description	Range	Default	Setting
Local Mode <i>Selects which function key will put the relay into Local Mode</i>	Combination of (1, 2, 3, 4, 5, 6, 7, 8, 9, 10, 11, 12)	-----	
Remote Mode <i>Selects which function key will put the relay into Remote Mode</i>	Combination of (1, 2, 3, 4, 5, 6, 7, 8, 9, 10, 11, 12)	-----	
Local Or Remote Mode <i>Selects which function key will put the relay into Local Or Remote Mode</i>	Combination of (1, 2, 3, 4, 5, 6, 7, 8, 9, 10, 11, 12)	-----	
MOS On/Off <i>Selects which function key will toggle the bypass mode of the Synchronisation check of the Manual Close</i>	Combination of (1, 2, 3, 4, 5, 6, 7, 8, 9, 10, 11, 12)	-----	
79 OS On/Off <i>Selects which function key will loggle the bypass mode of the Synchronisation check of the Auto-recloser</i>	Combination of (1, 2, 3, 4, 5, 6, 7, 8, 9, 10, 11, 12)	-----	
BatteryTestRequired <i>Selects which inputs will initiate a Battery test</i>	Combination of (1, 2, 3, 4, 5, 6, 7, 8, 9, 10, 11, 12)	-----	

3.8.3. Binary Input Config

Description	Range	Default	Setting
Inverted Inputs <i>Selects which inputs pickup when voltage is removed.</i>	Combination of (1, 2, 3, 4, 5, 6, 7, 8, 9, 10, 11, 12, 13, 14, 15, 16, 17, 18, 19, 20, 21, 22, 23, 24, 25, 26, 27, 28, 29, 30, 31, 32, 33)	----- -----	
BI 1 Pickup Delay <i>Delay on pickup of DC Binary Input 1</i>	0, 0.005 ... 14300, 14400	0.02s	
BI 1 Dropoff Delay <i>Delay on dropoff of DC Binary Input 1</i>	0, 0.005 ... 14300, 14400	0s	
BI 2 Pickup Delay <i>Delay on pickup of DC Binary Input 2</i>	0, 0.005 ... 14300, 14400	0.02s	
BI 2 Dropoff Delay <i>Delay on dropoff of DC Binary Input 2</i>	0, 0.005 ... 14300, 14400	0s	
BI 3 Pickup Delay <i>Delay on pickup of DC Binary Input 3</i>	0, 0.005 ... 14300, 14400	0.02s	
BI 3 Dropoff Delay <i>Delay on dropoff of DC Binary Input 3</i>	0, 0.005 ... 14300, 14400	0s	
BI 4 Pickup Delay <i>Delay on pickup of DC Binary Input 4</i>	0, 0.005 ... 14300, 14400	0.02s	
BI 4 Dropoff Delay <i>Delay on dropoff of DC Binary Input 4</i>	0, 0.005 ... 14300, 14400	0s	
BI 5 Pickup Delay <i>Delay on pickup of DC Binary Input 5</i>	0, 0.005 ... 14300, 14400	0.02s	
BI 5 Dropoff Delay <i>Delay on dropoff of DC Binary Input 5</i>	0, 0.005 ... 14300, 14400	0s	
BI 6 Pickup Delay <i>Delay on pickup of DC Binary Input 6</i>	0, 0.005 ... 14300, 14400	0.02s	

Description	Range	Default	Setting
BI 6 Dropoff Delay <i>Delay on dropoff of DC Binary Input 6</i>	0, 0.005 ... 14300, 14400	0s	
BI 7 Pickup Delay <i>Delay on pickup of DC Binary Input 7</i>	0, 0.005 ... 14300, 14400	0.02s	
BI 7 Dropoff Delay <i>Delay on dropoff of DC Binary Input 7</i>	0, 0.005 ... 14300, 14400	0s	
BI 8 Pickup Delay <i>Delay on pickup of DC Binary Input 8</i>	0, 0.005 ... 14300, 14400	0.02s	
BI 8 Dropoff Delay <i>Delay on dropoff of DC Binary Input 8</i>	0, 0.005 ... 14300, 14400	0s	
BI 9 Pickup Delay <i>Delay on pickup of DC Binary Input 9</i>	0, 0.005 ... 14300, 14400	0.02s	
BI 9 Dropoff Delay <i>Delay on dropoff of DC Binary Input 9</i>	0, 0.005 ... 14300, 14400	0s	
BI 10 Pickup Delay <i>Delay on pickup of DC Binary Input 10</i>	0, 0.005 ... 14300, 14400	0.02s	
BI 10 Dropoff Delay <i>Delay on dropoff of DC Binary Input 10</i>	0, 0.005 ... 14300, 14400	0s	
BI 11 Pickup Delay <i>Delay on pickup of DC Binary Input 11</i>	0, 0.005 ... 14300, 14400	0.02s	
BI 11 Dropoff Delay <i>Delay on dropoff of DC Binary Input 11</i>	0, 0.005 ... 14300, 14400	0s	
BI 12 Pickup Delay <i>Delay on pickup of DC Binary Input 12</i>	0, 0.005 ... 14300, 14400	0.02s	
BI 12 Dropoff Delay <i>Delay on dropoff of DC Binary Input 12</i>	0, 0.005 ... 14300, 14400	0s	
BI 13 Pickup Delay <i>Delay on pickup of DC Binary Input 13</i>	0, 0.005 ... 14300, 14400	0.02s	
BI 13 Dropoff Delay <i>Delay on dropoff of DC Binary Input 13</i>	0, 0.005 ... 14300, 14400	0s	
BI 14 Pickup Delay <i>Delay on pickup of DC Binary Input 14</i>	0, 0.005 ... 14300, 14400	0.02s	
BI 14 Dropoff Delay <i>Delay on dropoff of DC Binary Input 14</i>	0, 0.005 ... 14300, 14400	0s	
BI 15 Pickup Delay <i>Delay on pickup of DC Binary Input 15</i>	0, 0.005 ... 14300, 14400	0.02s	
BI 15 Dropoff Delay <i>Delay on dropoff of DC Binary Input 15</i>	0, 0.005 ... 14300, 14400	0s	
BI 16 Pickup Delay <i>Delay on pickup of DC Binary Input 16</i>	0, 0.005 ... 14300, 14400	0.02s	
BI 16 Dropoff Delay <i>Delay on dropoff of DC Binary Input 16</i>	0, 0.005 ... 14300, 14400	0s	
BI 17 Pickup Delay <i>Delay on pickup of DC Binary Input 17</i>	0, 0.005 ... 14300, 14400	0.02s	
BI 17 Dropoff Delay <i>Delay on dropoff of DC Binary Input 17</i>	0, 0.005 ... 14300, 14400	0s	
BI 18 Pickup Delay <i>Delay on pickup of DC Binary Input 18</i>	0, 0.005 ... 14300, 14400	0.02s	

Description	Range	Default	Setting
BI 18 Dropoff Delay <i>Delay on dropoff of DC Binary Input 18</i>	0, 0.005 ... 14300, 14400	0s	
BI 19 Pickup Delay <i>Delay on pickup of DC Binary Input 19</i>	0, 0.005 ... 14300, 14400	0.02s	
BI 19 Dropoff Delay <i>Delay on dropoff of DC Binary Input 19</i>	0, 0.005 ... 14300, 14400	0s	
BI 20 Pickup Delay <i>Delay on pickup of DC Binary Input 20</i>	0, 0.005 ... 14300, 14400	0.02s	
BI 20 Dropoff Delay <i>Delay on dropoff of DC Binary Input 20</i>	0, 0.005 ... 14300, 14400	0s	
BI 21 Pickup Delay <i>Delay on pickup of DC Binary Input 21</i>	0, 0.005 ... 14300, 14400	0.02s	
BI 21 Dropoff Delay <i>Delay on dropoff of DC Binary Input 21</i>	0, 0.005 ... 14300, 14400	0s	
BI 22 Pickup Delay <i>Delay on pickup of DC Binary Input 22</i>	0, 0.005 ... 14300, 14400	0.02s	
BI 22 Dropoff Delay <i>Delay on dropoff of DC Binary Input 22</i>	0, 0.005 ... 14300, 14400	0s	
BI 23 Pickup Delay <i>Delay on pickup of DC Binary Input 23</i>	0, 0.005 ... 14300, 14400	0.02s	
BI 23 Dropoff Delay <i>Delay on dropoff of DC Binary Input 23</i>	0, 0.005 ... 14300, 14400	0s	
BI 24 Pickup Delay <i>Delay on pickup of DC Binary Input 24</i>	0, 0.005 ... 14300, 14400	0.02s	
BI 24 Dropoff Delay <i>Delay on dropoff of DC Binary Input 24</i>	0, 0.005 ... 14300, 14400	0s	
BI 25 Pickup Delay <i>Delay on pickup of DC Binary Input 25</i>	0, 0.005 ... 14300, 14400	0.02s	
BI 25 Dropoff Delay <i>Delay on dropoff of DC Binary Input 25</i>	0, 0.005 ... 14300, 14400	0s	
BI 26 Pickup Delay <i>Delay on pickup of DC Binary Input 26</i>	0, 0.005 ... 14300, 14400	0.02s	
BI 26 Dropoff Delay <i>Delay on dropoff of DC Binary Input 26</i>	0, 0.005 ... 14300, 14400	0s	
BI 27 Pickup Delay <i>Delay on pickup of DC Binary Input 27</i>	0, 0.005 ... 14300, 14400	0.02s	
BI 27 Dropoff Delay <i>Delay on dropoff of DC Binary Input 27</i>	0, 0.005 ... 14300, 14400	0s	
BI 28 Pickup Delay <i>Delay on pickup of DC Binary Input 28</i>	0, 0.005 ... 14300, 14400	0.02s	
BI 28 Dropoff Delay <i>Delay on dropoff of DC Binary Input 28</i>	0, 0.005 ... 14300, 14400	0s	
BI 29 Pickup Delay <i>Delay on pickup of DC Binary Input 29</i>	0, 0.005 ... 14300, 14400	0.02s	
BI 29 Dropoff Delay <i>Delay on dropoff of DC Binary Input 29</i>	0, 0.005 ... 14300, 14400	0s	
BI 30 Pickup Delay <i>Delay on pickup of DC Binary Input 30</i>	0, 0.005 ... 14300, 14400	0.02s	

Description	Range	Default	Setting
BI 30 Dropoff Delay <i>Delay on dropoff of DC Binary Input 30</i>	0, 0.005 ... 14300, 14400	0s	
BI 31 Pickup Delay <i>Delay on pickup of DC Binary Input 31</i>	0, 0.005 ... 14300, 14400	0.02s	
BI 31 Dropoff Delay <i>Delay on dropoff of DC Binary Input 31</i>	0, 0.005 ... 14300, 14400	0s	
BI 32 Pickup Delay <i>Delay on pickup of DC Binary Input 32</i>	0, 0.005 ... 14300, 14400	0.02s	
BI 32 Dropoff Delay <i>Delay on dropoff of DC Binary Input 32</i>	0, 0.005 ... 14300, 14400	0s	
BI 33 Pickup Delay <i>Delay on pickup of DC Binary Input 33</i>	0, 0.005 ... 14300, 14400	0.02s	
BI 33 Dropoff Delay <i>Delay on dropoff of DC Binary Input 33</i>	0, 0.005 ... 14300, 14400	0s	
Enabled In Local <i>Selects which inputs are enabled when the relay is in Operating Mode 'Local' or 'Local Or Remote'</i>	Combination of (1, 2, 3, 4, 5, 6, 7, 8, 9, 10, 11, 12, 13, 14, 15, 16, 17, 18, 19, 20, 21, 22, 23, 24, 25, 26, 27, 28, 29, 30, 31, 32, 33)	1, 2, 3, 4, 5, 6, 7, 8, 9, 10, 11, 12, 13, 14, 15, 16, 17, 18, 19, 20, 21, 22, 23, 24, 25, 26, 27, 28, 29, 30, 31, 32, 33	
Enabled In Remote <i>Selects which inputs are enabled when the relay is in Operating Mode 'Remote' or 'Local Or Remote'</i>	Combination of (1, 2, 3, 4, 5, 6, 7, 8, 9, 10, 11, 12, 13, 14, 15, 16, 17, 18, 19, 20, 21, 22, 23, 24, 25, 26, 27, 28, 29, 30, 31, 32, 33)	1, 2, 3, 4, 5, 6, 7, 8, 9, 10, 11, 12, 13, 14, 15, 16, 17, 18, 19, 20, 21, 22, 23, 24, 25, 26, 27, 28, 29, 30, 31, 32, 33	

3.8.4. Function Key Config

Description	Range	Default	Setting
Function Key 1 Text <i>User definable text that will be used in the HMI function key confirmation screen when Function key 1 is pressed.</i>	(20 Character String)	Function Key 1	
Function Key 2 Text <i>User definable text that will be used in the HMI function key confirmation screen when Function key 2 is pressed.</i>	(20 Character String)	Function Key 2	
Function Key 3 Text <i>User definable text that will be used in the HMI function key confirmation screen when Function key 3 is pressed.</i>	(20 Character String)	Function Key 3	
Function Key 4 Text <i>User definable text that will be used in the HMI function key confirmation screen when Function key 4 is pressed.</i>	(20 Character String)	Function Key 4	

Description	Range	Default	Setting
Function Key 5 Text <i>User definable text that will be used in the HMI function key confirmation screen when Function key 5 is pressed.</i>	(20 Character String)	Function Key 5	
Function Key 6 Text <i>User definable text that will be used in the HMI function key confirmation screen when Function key 6 is pressed.</i>	(20 Character String)	Function Key 6	
Function Key 7 Text <i>User definable text that will be used in the HMI function key confirmation screen when Function key 7 is pressed.</i>	(20 Character String)	Function Key 7	
Function Key 8 Text <i>User definable text that will be used in the HMI function key confirmation screen when Function key 8 is pressed.</i>	(20 Character String)	Function Key 8	
Function Key 9 Text <i>User definable text that will be used in the HMI function key confirmation screen when Function key 9 is pressed.</i>	(20 Character String)	Function Key 9	
Function Key 10 Text <i>User definable text that will be used in the HMI function key confirmation screen when Function key 10 is pressed.</i>	(20 Character String)	Function Key 10	
Function Key 11 Text <i>User definable text that will be used in the HMI function key confirmation screen when Function key 11 is pressed.</i>	(20 Character String)	Function Key 11	
Function Key 12 Text <i>User definable text that will be used in the HMI function key confirmation screen when Function key 12 is pressed.</i>	(20 Character String)	Function Key 12	
Enabled In Remote <i>Selects which inputs are enabled when the relay is in Operating Mode 'Remote' or 'Local Or Remote'</i>	Combination of (1, 2, 3, 4, 5, 6, 7, 8, 9, 10, 11, 12)	----- 1668183366	

3.8.5. General Alarms

Description	Range	Default	Setting
General Alarm-1 <i>Defines the text to be displayed for General Alarm 1</i>	(16 Character String)	ALARM 1	
General Alarm-2 <i>Defines the text to be displayed for General Alarm 2</i>	(16 Character String)	ALARM 2	
General Alarm-3 <i>Defines the text to be displayed for General Alarm 3</i>	(16 Character String)	ALARM 3	
General Alarm-4 <i>Defines the text to be displayed for General Alarm 4</i>	(16 Character String)	ALARM 4	
General Alarm-5 <i>Defines the text to be displayed for General Alarm 5</i>	(16 Character String)	ALARM 5	

Description	Range	Default	Setting
General Alarm-6 <i>Defines the text to be displayed for General Alarm 6</i>	(16 Character String)	ALARM 6	
General Alarm-7 <i>Defines the text to be displayed for General Alarm 7</i>	(16 Character String)	ALARM 7	
General Alarm-8 <i>Defines the text to be displayed for General Alarm 8</i>	(16 Character String)	ALARM 8	
General Alarm-9 <i>Defines the text to be displayed for General Alarm 9</i>	(16 Character String)	ALARM 9	
General Alarm-10 <i>Defines the text to be displayed for General Alarm 10</i>	(16 Character String)	ALARM 10	
General Alarm-11 <i>Defines the text to be displayed for General Alarm 11</i>	(16 Character String)	ALARM 11	
General Alarm-12 <i>Defines the text to be displayed for General Alarm 12</i>	(16 Character String)	ALARM 12	

3.9. Output Config

3.9.1. Output Matrix

Description	Range	Default	Setting
Protection Healthy <i>Relays selected are energised whilst relay self-monitoring does NOT detect any hardware or software errors and DC Supply is healthy. A changeover contact or normally closed contact may be used to generate Protection Defective from this output</i>	Combination of (BO1, BO2, BO3, BO4, BO5, BO6, BO7, BO8, BO9, BO10, BO11, BO12, BO13, BO14, L1, L2, L3, L4, L5, L6, L7, L8, L9, L10, L11, L12, L13, L14, L15, L16, L17, L18, L19, L20, V1, V2, V3, V4, V5, V6, V7, V8, V9, V10, V11, V12, V13, V14, V15, V16)	BO1	
51-1 <i>51-1 IDMTL/DTL Overcurrent operated</i>	Combination of (BO1, BO2, BO3, BO4, BO5, BO6, BO7, BO8, BO9, BO10, BO11, BO12, BO13, BO14, L1, L2, L3, L4, L5, L6, L7, L8, L9, L10, L11, L12, L13, L14, L15, L16, L17, L18, L19, L20, V1, V2, V3, V4, V5, V6, V7, V8, V9, V10, V11, V12, V13, V14, V15, V16)	----- ----- -----	

Description	Range	Default	Setting
51-2 <i>51-2 IDMTL/DTL Overcurrent operated</i>	Combination of (BO1, BO2, BO3, BO4, BO5, BO6, BO7, BO8, BO9, BO10, BO11, BO12, BO13, BO14, L1, L2, L3, L4, L5, L6, L7, L8, L9, L10, L11, L12, L13, L14, L15, L16, L17, L18, L19, L20, V1, V2, V3, V4, V5, V6, V7, V8, V9, V10, V11, V12, V13, V14, V15, V16)	----- ----- -----	
51-3 <i>51-3 IDMTL/DTL Overcurrent operated</i>	Combination of (BO1, BO2, BO3, BO4, BO5, BO6, BO7, BO8, BO9, BO10, BO11, BO12, BO13, BO14, L1, L2, L3, L4, L5, L6, L7, L8, L9, L10, L11, L12, L13, L14, L15, L16, L17, L18, L19, L20, V1, V2, V3, V4, V5, V6, V7, V8, V9, V10, V11, V12, V13, V14, V15, V16)	----- ----- -----	
51-4 <i>51-4 IDMTL/DTL Overcurrent operated</i>	Combination of (BO1, BO2, BO3, BO4, BO5, BO6, BO7, BO8, BO9, BO10, BO11, BO12, BO13, BO14, L1, L2, L3, L4, L5, L6, L7, L8, L9, L10, L11, L12, L13, L14, L15, L16, L17, L18, L19, L20, V1, V2, V3, V4, V5, V6, V7, V8, V9, V10, V11, V12, V13, V14, V15, V16)	----- ----- -----	
50-1 <i>50-1 INST/DTL Overcurrent operated</i>	Combination of (BO1, BO2, BO3, BO4, BO5, BO6, BO7, BO8, BO9, BO10, BO11, BO12, BO13, BO14, L1, L2, L3, L4, L5, L6, L7, L8, L9, L10, L11, L12, L13, L14, L15, L16, L17, L18, L19, L20, V1, V2, V3, V4, V5, V6, V7, V8, V9, V10, V11, V12, V13, V14, V15, V16)	----- ----- -----	
50-2 <i>50-2 INST/DTL Overcurrent operated</i>	Combination of (BO1, BO2, BO3, BO4, BO5, BO6, BO7, BO8, BO9, BO10, BO11, BO12, BO13, BO14, L1, L2, L3, L4, L5, L6, L7, L8, L9, L10, L11, L12, L13, L14, L15, L16, L17, L18, L19, L20, V1, V2, V3, V4, V5, V6, V7, V8, V9, V10, V11, V12, V13, V14, V15, V16)	----- ----- -----	
50-3 <i>50-3 INST/DTL Overcurrent operated</i>	Combination of (BO1, BO2, BO3, BO4, BO5, BO6, BO7, BO8, BO9, BO10, BO11, BO12, BO13, BO14, L1, L2, L3, L4, L5, L6, L7, L8, L9, L10, L11, L12, L13, L14, L15, L16, L17, L18, L19, L20, V1, V2, V3, V4, V5, V6, V7, V8, V9, V10, V11, V12, V13, V14, V15, V16)	----- ----- -----	

Description	Range	Default	Setting
50-4 <i>50-4 INST/DTL Overcurrent operated</i>	Combination of (BO1, BO2, BO3, BO4, BO5, BO6, BO7, BO8, BO9, BO10, BO11, BO12, BO13, BO14, L1, L2, L3, L4, L5, L6, L7, L8, L9, L10, L11, L12, L13, L14, L15, L16, L17, L18, L19, L20, V1, V2, V3, V4, V5, V6, V7, V8, V9, V10, V11, V12, V13, V14, V15, V16)	----- ----- -----	
51G-1 <i>51G-1 IDMTL/DTL measured Earth Fault operated</i>	Combination of (BO1, BO2, BO3, BO4, BO5, BO6, BO7, BO8, BO9, BO10, BO11, BO12, BO13, BO14, L1, L2, L3, L4, L5, L6, L7, L8, L9, L10, L11, L12, L13, L14, L15, L16, L17, L18, L19, L20, V1, V2, V3, V4, V5, V6, V7, V8, V9, V10, V11, V12, V13, V14, V15, V16)	L4	
51G-2 <i>51G-2 IDMTL/DTL measured Earth Fault operated</i>	Combination of (BO1, BO2, BO3, BO4, BO5, BO6, BO7, BO8, BO9, BO10, BO11, BO12, BO13, BO14, L1, L2, L3, L4, L5, L6, L7, L8, L9, L10, L11, L12, L13, L14, L15, L16, L17, L18, L19, L20, V1, V2, V3, V4, V5, V6, V7, V8, V9, V10, V11, V12, V13, V14, V15, V16)	L4	
51G-3 <i>51G-3 IDMTL/DTL measured Earth Fault operated</i>	Combination of (BO1, BO2, BO3, BO4, BO5, BO6, BO7, BO8, BO9, BO10, BO11, BO12, BO13, BO14, L1, L2, L3, L4, L5, L6, L7, L8, L9, L10, L11, L12, L13, L14, L15, L16, L17, L18, L19, L20, V1, V2, V3, V4, V5, V6, V7, V8, V9, V10, V11, V12, V13, V14, V15, V16)	L4	
51G-4 <i>51G-4 IDMTL/DTL measured Earth Fault operated</i>	Combination of (BO1, BO2, BO3, BO4, BO5, BO6, BO7, BO8, BO9, BO10, BO11, BO12, BO13, BO14, L1, L2, L3, L4, L5, L6, L7, L8, L9, L10, L11, L12, L13, L14, L15, L16, L17, L18, L19, L20, V1, V2, V3, V4, V5, V6, V7, V8, V9, V10, V11, V12, V13, V14, V15, V16)	L4	
50G-1 <i>50G-1 INST/DTL measured Earth Fault operated</i>	Combination of (BO1, BO2, BO3, BO4, BO5, BO6, BO7, BO8, BO9, BO10, BO11, BO12, BO13, BO14, L1, L2, L3, L4, L5, L6, L7, L8, L9, L10, L11, L12, L13, L14, L15, L16, L17, L18, L19, L20, V1, V2, V3, V4, V5, V6, V7, V8, V9, V10, V11, V12, V13, V14, V15, V16)	L4	

Description	Range	Default	Setting
50G-2 <i>50G-2 INST/DTL measured Earth Fault operated</i>	Combination of (BO1, BO2, BO3, BO4, BO5, BO6, BO7, BO8, BO9, BO10, BO11, BO12, BO13, BO14, L1, L2, L3, L4, L5, L6, L7, L8, L9, L10, L11, L12, L13, L14, L15, L16, L17, L18, L19, L20, V1, V2, V3, V4, V5, V6, V7, V8, V9, V10, V11, V12, V13, V14, V15, V16)	L4	
50G-3 <i>50G-3 INST/DTL measured Earth Fault operated</i>	Combination of (BO1, BO2, BO3, BO4, BO5, BO6, BO7, BO8, BO9, BO10, BO11, BO12, BO13, BO14, L1, L2, L3, L4, L5, L6, L7, L8, L9, L10, L11, L12, L13, L14, L15, L16, L17, L18, L19, L20, V1, V2, V3, V4, V5, V6, V7, V8, V9, V10, V11, V12, V13, V14, V15, V16)	L4	
50G-4 <i>50G-4 INST/DTL measured Earth Fault operated</i>	Combination of (BO1, BO2, BO3, BO4, BO5, BO6, BO7, BO8, BO9, BO10, BO11, BO12, BO13, BO14, L1, L2, L3, L4, L5, L6, L7, L8, L9, L10, L11, L12, L13, L14, L15, L16, L17, L18, L19, L20, V1, V2, V3, V4, V5, V6, V7, V8, V9, V10, V11, V12, V13, V14, V15, V16)	L4	
51SEF-1 <i>51SEF-1 IDMTL/DTL Sensitive Earth Fault operated</i>	Combination of (BO1, BO2, BO3, BO4, BO5, BO6, BO7, BO8, BO9, BO10, BO11, BO12, BO13, BO14, L1, L2, L3, L4, L5, L6, L7, L8, L9, L10, L11, L12, L13, L14, L15, L16, L17, L18, L19, L20, V1, V2, V3, V4, V5, V6, V7, V8, V9, V10, V11, V12, V13, V14, V15, V16)	L5	
51SEF-2 <i>51SEF-2 IDMTL/DTL Sensitive Earth Fault operated</i>	Combination of (BO1, BO2, BO3, BO4, BO5, BO6, BO7, BO8, BO9, BO10, BO11, BO12, BO13, BO14, L1, L2, L3, L4, L5, L6, L7, L8, L9, L10, L11, L12, L13, L14, L15, L16, L17, L18, L19, L20, V1, V2, V3, V4, V5, V6, V7, V8, V9, V10, V11, V12, V13, V14, V15, V16)	L5	
51SEF-3 <i>51SEF-3 IDMTL/DTL Sensitive Earth Fault operated</i>	Combination of (BO1, BO2, BO3, BO4, BO5, BO6, BO7, BO8, BO9, BO10, BO11, BO12, BO13, BO14, L1, L2, L3, L4, L5, L6, L7, L8, L9, L10, L11, L12, L13, L14, L15, L16, L17, L18, L19, L20, V1, V2, V3, V4, V5, V6, V7, V8, V9, V10, V11, V12, V13, V14, V15, V16)	L5	

Description	Range	Default	Setting
51SEF-4 <i>51SEF-4 IDMTL/DTL Sensitive Earth Fault operated</i>	Combination of (BO1, BO2, BO3, BO4, BO5, BO6, BO7, BO8, BO9, BO10, BO11, BO12, BO13, BO14, L1, L2, L3, L4, L5, L6, L7, L8, L9, L10, L11, L12, L13, L14, L15, L16, L17, L18, L19, L20, V1, V2, V3, V4, V5, V6, V7, V8, V9, V10, V11, V12, V13, V14, V15, V16)	L5	
50SEF-1 <i>50SEF-1 INST/DTL Sensitive Earth Fault operated</i>	Combination of (BO1, BO2, BO3, BO4, BO5, BO6, BO7, BO8, BO9, BO10, BO11, BO12, BO13, BO14, L1, L2, L3, L4, L5, L6, L7, L8, L9, L10, L11, L12, L13, L14, L15, L16, L17, L18, L19, L20, V1, V2, V3, V4, V5, V6, V7, V8, V9, V10, V11, V12, V13, V14, V15, V16)	L5	
50SEF-2 <i>50SEF-2 INST/DTL Sensitive Earth Fault operated</i>	Combination of (BO1, BO2, BO3, BO4, BO5, BO6, BO7, BO8, BO9, BO10, BO11, BO12, BO13, BO14, L1, L2, L3, L4, L5, L6, L7, L8, L9, L10, L11, L12, L13, L14, L15, L16, L17, L18, L19, L20, V1, V2, V3, V4, V5, V6, V7, V8, V9, V10, V11, V12, V13, V14, V15, V16)	L5	
50SEF-3 <i>50SEF-3 INST/DTL Sensitive Earth Fault operated</i>	Combination of (BO1, BO2, BO3, BO4, BO5, BO6, BO7, BO8, BO9, BO10, BO11, BO12, BO13, BO14, L1, L2, L3, L4, L5, L6, L7, L8, L9, L10, L11, L12, L13, L14, L15, L16, L17, L18, L19, L20, V1, V2, V3, V4, V5, V6, V7, V8, V9, V10, V11, V12, V13, V14, V15, V16)	L5	
50SEF-4 <i>50SEF-4 INST/DTL Sensitive Earth Fault operated</i>	Combination of (BO1, BO2, BO3, BO4, BO5, BO6, BO7, BO8, BO9, BO10, BO11, BO12, BO13, BO14, L1, L2, L3, L4, L5, L6, L7, L8, L9, L10, L11, L12, L13, L14, L15, L16, L17, L18, L19, L20, V1, V2, V3, V4, V5, V6, V7, V8, V9, V10, V11, V12, V13, V14, V15, V16)	L5	
64H <i>64H Restricted Earth Fault element operated</i>	Combination of (BO1, BO2, BO3, BO4, BO5, BO6, BO7, BO8, BO9, BO10, BO11, BO12, BO13, BO14, L1, L2, L3, L4, L5, L6, L7, L8, L9, L10, L11, L12, L13, L14, L15, L16, L17, L18, L19, L20, V1, V2, V3, V4, V5, V6, V7, V8, V9, V10, V11, V12, V13, V14, V15, V16)	----- ----- -----	

Description	Range	Default	Setting
Cold Load Active <i>Cold Load settings are active</i>	Combination of (BO1, BO2, BO3, BO4, BO5, BO6, BO7, BO8, BO9, BO10, BO11, BO12, BO13, BO14, L1, L2, L3, L4, L5, L6, L7, L8, L9, L10, L11, L12, L13, L14, L15, L16, L17, L18, L19, L20, V1, V2, V3, V4, V5, V6, V7, V8, V9, V10, V11, V12, V13, V14, V15, V16)	----- ----- -----	
46IT <i>IDMTL/DTL NPS Overcurrent operated</i>	Combination of (BO1, BO2, BO3, BO4, BO5, BO6, BO7, BO8, BO9, BO10, BO11, BO12, BO13, BO14, L1, L2, L3, L4, L5, L6, L7, L8, L9, L10, L11, L12, L13, L14, L15, L16, L17, L18, L19, L20, V1, V2, V3, V4, V5, V6, V7, V8, V9, V10, V11, V12, V13, V14, V15, V16)	----- ----- -----	
46DT <i>INST/DTL NPS Overcurrent operated</i>	Combination of (BO1, BO2, BO3, BO4, BO5, BO6, BO7, BO8, BO9, BO10, BO11, BO12, BO13, BO14, L1, L2, L3, L4, L5, L6, L7, L8, L9, L10, L11, L12, L13, L14, L15, L16, L17, L18, L19, L20, V1, V2, V3, V4, V5, V6, V7, V8, V9, V10, V11, V12, V13, V14, V15, V16)	----- ----- -----	
37-1 <i>37-1 Under Current operated</i>	Combination of (BO1, BO2, BO3, BO4, BO5, BO6, BO7, BO8, BO9, BO10, BO11, BO12, BO13, BO14, L1, L2, L3, L4, L5, L6, L7, L8, L9, L10, L11, L12, L13, L14, L15, L16, L17, L18, L19, L20, V1, V2, V3, V4, V5, V6, V7, V8, V9, V10, V11, V12, V13, V14, V15, V16)	----- ----- -----	
37-2 <i>37-2 Under Current operated</i>	Combination of (BO1, BO2, BO3, BO4, BO5, BO6, BO7, BO8, BO9, BO10, BO11, BO12, BO13, BO14, L1, L2, L3, L4, L5, L6, L7, L8, L9, L10, L11, L12, L13, L14, L15, L16, L17, L18, L19, L20, V1, V2, V3, V4, V5, V6, V7, V8, V9, V10, V11, V12, V13, V14, V15, V16)	----- ----- -----	
49 Trip <i>Thermal capacity trip operated</i>	Combination of (BO1, BO2, BO3, BO4, BO5, BO6, BO7, BO8, BO9, BO10, BO11, BO12, BO13, BO14, L1, L2, L3, L4, L5, L6, L7, L8, L9, L10, L11, L12, L13, L14, L15, L16, L17, L18, L19, L20, V1, V2, V3, V4, V5, V6, V7, V8, V9, V10, V11, V12, V13, V14, V15, V16)	----- ----- -----	

Description	Range	Default	Setting
49 Alarm <i>Thermal capacity alarm operated</i>	Combination of (BO1, BO2, BO3, BO4, BO5, BO6, BO7, BO8, BO9, BO10, BO11, BO12, BO13, BO14, L1, L2, L3, L4, L5, L6, L7, L8, L9, L10, L11, L12, L13, L14, L15, L16, L17, L18, L19, L20, V1, V2, V3, V4, V5, V6, V7, V8, V9, V10, V11, V12, V13, V14, V15, V16)	----- ----- -----	
27/59-1 <i>Under/Overtension stage 1 operated</i>	Combination of (BO1, BO2, BO3, BO4, BO5, BO6, BO7, BO8, BO9, BO10, BO11, BO12, BO13, BO14, L1, L2, L3, L4, L5, L6, L7, L8, L9, L10, L11, L12, L13, L14, L15, L16, L17, L18, L19, L20, V1, V2, V3, V4, V5, V6, V7, V8, V9, V10, V11, V12, V13, V14, V15, V16)	----- ----- -----	
27/59-2 <i>Under/Overtension stage 2 operated</i>	Combination of (BO1, BO2, BO3, BO4, BO5, BO6, BO7, BO8, BO9, BO10, BO11, BO12, BO13, BO14, L1, L2, L3, L4, L5, L6, L7, L8, L9, L10, L11, L12, L13, L14, L15, L16, L17, L18, L19, L20, V1, V2, V3, V4, V5, V6, V7, V8, V9, V10, V11, V12, V13, V14, V15, V16)	----- ----- -----	
27/59-3 <i>Under/Overtension stage 3 operated</i>	Combination of (BO1, BO2, BO3, BO4, BO5, BO6, BO7, BO8, BO9, BO10, BO11, BO12, BO13, BO14, L1, L2, L3, L4, L5, L6, L7, L8, L9, L10, L11, L12, L13, L14, L15, L16, L17, L18, L19, L20, V1, V2, V3, V4, V5, V6, V7, V8, V9, V10, V11, V12, V13, V14, V15, V16)	----- ----- -----	
27/59-4 <i>Under/Overtension stage 4 operated</i>	Combination of (BO1, BO2, BO3, BO4, BO5, BO6, BO7, BO8, BO9, BO10, BO11, BO12, BO13, BO14, L1, L2, L3, L4, L5, L6, L7, L8, L9, L10, L11, L12, L13, L14, L15, L16, L17, L18, L19, L20, V1, V2, V3, V4, V5, V6, V7, V8, V9, V10, V11, V12, V13, V14, V15, V16)	----- ----- -----	
Vx 27/59 <i>Under/Overtension Vx stage operated</i>	Combination of (BO1, BO2, BO3, BO4, BO5, BO6, BO7, BO8, BO9, BO10, BO11, BO12, BO13, BO14, L1, L2, L3, L4, L5, L6, L7, L8, L9, L10, L11, L12, L13, L14, L15, L16, L17, L18, L19, L20, V1, V2, V3, V4, V5, V6, V7, V8, V9, V10, V11, V12, V13, V14, V15, V16)	----- ----- -----	

Description	Range	Default	Setting
47-1 <i>INST/DTL NPS Overvoltage stage 1 operated</i>	Combination of (BO1, BO2, BO3, BO4, BO5, BO6, BO7, BO8, BO9, BO10, BO11, BO12, BO13, BO14, L1, L2, L3, L4, L5, L6, L7, L8, L9, L10, L11, L12, L13, L14, L15, L16, L17, L18, L19, L20, V1, V2, V3, V4, V5, V6, V7, V8, V9, V10, V11, V12, V13, V14, V15, V16)	----- ----- -----	
47-2 <i>INST/DTL NPS Overvoltage stage 2 operated</i>	Combination of (BO1, BO2, BO3, BO4, BO5, BO6, BO7, BO8, BO9, BO10, BO11, BO12, BO13, BO14, L1, L2, L3, L4, L5, L6, L7, L8, L9, L10, L11, L12, L13, L14, L15, L16, L17, L18, L19, L20, V1, V2, V3, V4, V5, V6, V7, V8, V9, V10, V11, V12, V13, V14, V15, V16)	----- ----- -----	
59NIT <i>Neutral Overvoltage IDMTL/DTL operated</i>	Combination of (BO1, BO2, BO3, BO4, BO5, BO6, BO7, BO8, BO9, BO10, BO11, BO12, BO13, BO14, L1, L2, L3, L4, L5, L6, L7, L8, L9, L10, L11, L12, L13, L14, L15, L16, L17, L18, L19, L20, V1, V2, V3, V4, V5, V6, V7, V8, V9, V10, V11, V12, V13, V14, V15, V16)	----- ----- -----	
59NDT <i>Neutral Overvoltage INST/DTL operated</i>	Combination of (BO1, BO2, BO3, BO4, BO5, BO6, BO7, BO8, BO9, BO10, BO11, BO12, BO13, BO14, L1, L2, L3, L4, L5, L6, L7, L8, L9, L10, L11, L12, L13, L14, L15, L16, L17, L18, L19, L20, V1, V2, V3, V4, V5, V6, V7, V8, V9, V10, V11, V12, V13, V14, V15, V16)	----- ----- -----	
81-1 <i>Under/Over frequency stage 1 operated</i>	Combination of (BO1, BO2, BO3, BO4, BO5, BO6, BO7, BO8, BO9, BO10, BO11, BO12, BO13, BO14, L1, L2, L3, L4, L5, L6, L7, L8, L9, L10, L11, L12, L13, L14, L15, L16, L17, L18, L19, L20, V1, V2, V3, V4, V5, V6, V7, V8, V9, V10, V11, V12, V13, V14, V15, V16)	----- ----- -----	
81-2 <i>Under/Over frequency stage 2 operated</i>	Combination of (BO1, BO2, BO3, BO4, BO5, BO6, BO7, BO8, BO9, BO10, BO11, BO12, BO13, BO14, L1, L2, L3, L4, L5, L6, L7, L8, L9, L10, L11, L12, L13, L14, L15, L16, L17, L18, L19, L20, V1, V2, V3, V4, V5, V6, V7, V8, V9, V10, V11, V12, V13, V14, V15, V16)	----- ----- -----	

Description	Range	Default	Setting
81-3 <i>Under/Over frequency stage 3 operated</i>	Combination of (BO1, BO2, BO3, BO4, BO5, BO6, BO7, BO8, BO9, BO10, BO11, BO12, BO13, BO14, L1, L2, L3, L4, L5, L6, L7, L8, L9, L10, L11, L12, L13, L14, L15, L16, L17, L18, L19, L20, V1, V2, V3, V4, V5, V6, V7, V8, V9, V10, V11, V12, V13, V14, V15, V16)	----- ----- -----	
81-4 <i>Under/Over frequency stage 4 operated</i>	Combination of (BO1, BO2, BO3, BO4, BO5, BO6, BO7, BO8, BO9, BO10, BO11, BO12, BO13, BO14, L1, L2, L3, L4, L5, L6, L7, L8, L9, L10, L11, L12, L13, L14, L15, L16, L17, L18, L19, L20, V1, V2, V3, V4, V5, V6, V7, V8, V9, V10, V11, V12, V13, V14, V15, V16)	----- ----- -----	
60CTS <i>CT Supervision element operated</i>	Combination of (BO1, BO2, BO3, BO4, BO5, BO6, BO7, BO8, BO9, BO10, BO11, BO12, BO13, BO14, L1, L2, L3, L4, L5, L6, L7, L8, L9, L10, L11, L12, L13, L14, L15, L16, L17, L18, L19, L20, V1, V2, V3, V4, V5, V6, V7, V8, V9, V10, V11, V12, V13, V14, V15, V16)	----- ----- -----	
46BC <i>46 Broken Conductor element operated</i>	Combination of (BO1, BO2, BO3, BO4, BO5, BO6, BO7, BO8, BO9, BO10, BO11, BO12, BO13, BO14, L1, L2, L3, L4, L5, L6, L7, L8, L9, L10, L11, L12, L13, L14, L15, L16, L17, L18, L19, L20, V1, V2, V3, V4, V5, V6, V7, V8, V9, V10, V11, V12, V13, V14, V15, V16)	----- ----- -----	
74TCS-1 <i>Trip Circuit 1 fail operated</i>	Combination of (BO1, BO2, BO3, BO4, BO5, BO6, BO7, BO8, BO9, BO10, BO11, BO12, BO13, BO14, L1, L2, L3, L4, L5, L6, L7, L8, L9, L10, L11, L12, L13, L14, L15, L16, L17, L18, L19, L20, V1, V2, V3, V4, V5, V6, V7, V8, V9, V10, V11, V12, V13, V14, V15, V16)	----- ----- -----	
74TCS-2 <i>Trip Circuit 2 fail operated</i>	Combination of (BO1, BO2, BO3, BO4, BO5, BO6, BO7, BO8, BO9, BO10, BO11, BO12, BO13, BO14, L1, L2, L3, L4, L5, L6, L7, L8, L9, L10, L11, L12, L13, L14, L15, L16, L17, L18, L19, L20, V1, V2, V3, V4, V5, V6, V7, V8, V9, V10, V11, V12, V13, V14, V15, V16)	----- ----- -----	

Description	Range	Default	Setting
74TCS-3 <i>Trip Circuit 3 fail operated</i>	Combination of (BO1, BO2, BO3, BO4, BO5, BO6, BO7, BO8, BO9, BO10, BO11, BO12, BO13, BO14, L1, L2, L3, L4, L5, L6, L7, L8, L9, L10, L11, L12, L13, L14, L15, L16, L17, L18, L19, L20, V1, V2, V3, V4, V5, V6, V7, V8, V9, V10, V11, V12, V13, V14, V15, V16)	----- ----- -----	
General Pickup <i>General Pickup operated</i>	Combination of (BO1, BO2, BO3, BO4, BO5, BO6, BO7, BO8, BO9, BO10, BO11, BO12, BO13, BO14, L1, L2, L3, L4, L5, L6, L7, L8, L9, L10, L11, L12, L13, L14, L15, L16, L17, L18, L19, L20, V1, V2, V3, V4, V5, V6, V7, V8, V9, V10, V11, V12, V13, V14, V15, V16)	----- ----- -----	
50BF-1 <i>Circuit Breaker Fail stage 1 operated</i>	Combination of (BO1, BO2, BO3, BO4, BO5, BO6, BO7, BO8, BO9, BO10, BO11, BO12, BO13, BO14, L1, L2, L3, L4, L5, L6, L7, L8, L9, L10, L11, L12, L13, L14, L15, L16, L17, L18, L19, L20, V1, V2, V3, V4, V5, V6, V7, V8, V9, V10, V11, V12, V13, V14, V15, V16)	----- ----- -----	
50BF-2 <i>Circuit Breaker Fail stage 2 operated</i>	Combination of (BO1, BO2, BO3, BO4, BO5, BO6, BO7, BO8, BO9, BO10, BO11, BO12, BO13, BO14, L1, L2, L3, L4, L5, L6, L7, L8, L9, L10, L11, L12, L13, L14, L15, L16, L17, L18, L19, L20, V1, V2, V3, V4, V5, V6, V7, V8, V9, V10, V11, V12, V13, V14, V15, V16)	----- ----- -----	
60VTS <i>VT Supervision element operated</i>	Combination of (BO1, BO2, BO3, BO4, BO5, BO6, BO7, BO8, BO9, BO10, BO11, BO12, BO13, BO14, L1, L2, L3, L4, L5, L6, L7, L8, L9, L10, L11, L12, L13, L14, L15, L16, L17, L18, L19, L20, V1, V2, V3, V4, V5, V6, V7, V8, V9, V10, V11, V12, V13, V14, V15, V16)	----- ----- -----	
60VTF-Bus <i>Bus VT Fail element operated</i>	Combination of (BO1, BO2, BO3, BO4, BO5, BO6, BO7, BO8, BO9, BO10, BO11, BO12, BO13, BO14, L1, L2, L3, L4, L5, L6, L7, L8, L9, L10, L11, L12, L13, L14, L15, L16, L17, L18, L19, L20, V1, V2, V3, V4, V5, V6, V7, V8, V9, V10, V11, V12, V13, V14, V15, V16)	----- ----- -----	

Description	Range	Default	Setting
CB Total Trip Count <i>Total CB trip count exceeded</i>	Combination of (BO1, BO2, BO3, BO4, BO5, BO6, BO7, BO8, BO9, BO10, BO11, BO12, BO13, BO14, L1, L2, L3, L4, L5, L6, L7, L8, L9, L10, L11, L12, L13, L14, L15, L16, L17, L18, L19, L20, V1, V2, V3, V4, V5, V6, V7, V8, V9, V10, V11, V12, V13, V14, V15, V16)	----- ----- -----	
CB Delta Trip Count <i>Delta CB trip count exceeded</i>	Combination of (BO1, BO2, BO3, BO4, BO5, BO6, BO7, BO8, BO9, BO10, BO11, BO12, BO13, BO14, L1, L2, L3, L4, L5, L6, L7, L8, L9, L10, L11, L12, L13, L14, L15, L16, L17, L18, L19, L20, V1, V2, V3, V4, V5, V6, V7, V8, V9, V10, V11, V12, V13, V14, V15, V16)	----- ----- -----	
CB Count To ARBlock <i>Count To AR Block CB trip count exceeded</i>	Combination of (BO1, BO2, BO3, BO4, BO5, BO6, BO7, BO8, BO9, BO10, BO11, BO12, BO13, BO14, L1, L2, L3, L4, L5, L6, L7, L8, L9, L10, L11, L12, L13, L14, L15, L16, L17, L18, L19, L20, V1, V2, V3, V4, V5, V6, V7, V8, V9, V10, V11, V12, V13, V14, V15, V16)	----- ----- -----	
CB Freq Ops Count <i>CB Frequent Operations count exceeded</i>	Combination of (BO1, BO2, BO3, BO4, BO5, BO6, BO7, BO8, BO9, BO10, BO11, BO12, BO13, BO14, L1, L2, L3, L4, L5, L6, L7, L8, L9, L10, L11, L12, L13, L14, L15, L16, L17, L18, L19, L20, V1, V2, V3, V4, V5, V6, V7, V8, V9, V10, V11, V12, V13, V14, V15, V16)	----- ----- -----	
CB LO Handle Ops <i>CB Lockout Handle Operations count exceeded</i>	Combination of (BO1, BO2, BO3, BO4, BO5, BO6, BO7, BO8, BO9, BO10, BO11, BO12, BO13, BO14, L1, L2, L3, L4, L5, L6, L7, L8, L9, L10, L11, L12, L13, L14, L15, L16, L17, L18, L19, L20, V1, V2, V3, V4, V5, V6, V7, V8, V9, V10, V11, V12, V13, V14, V15, V16)	----- ----- -----	
I ² t CB Wear <i>I²t CB Wear limit exceeded</i>	Combination of (BO1, BO2, BO3, BO4, BO5, BO6, BO7, BO8, BO9, BO10, BO11, BO12, BO13, BO14, L1, L2, L3, L4, L5, L6, L7, L8, L9, L10, L11, L12, L13, L14, L15, L16, L17, L18, L19, L20, V1, V2, V3, V4, V5, V6, V7, V8, V9, V10, V11, V12, V13, V14, V15, V16)	----- ----- -----	

Description	Range	Default	Setting
<p>Battery Test</p> <p><i>Battery Test is in progress. This can be used to disable battery charger during a battery test.</i></p>	<p>Combination of (BO1, BO2, BO3, BO4, BO5, BO6, BO7, BO8, BO9, BO10, BO11, BO12, BO13, BO14, L1, L2, L3, L4, L5, L6, L7, L8, L9, L10, L11, L12, L13, L14, L15, L16, L17, L18, L19, L20, V1, V2, V3, V4, V5, V6, V7, V8, V9, V10, V11, V12, V13, V14, V15, V16)</p>	<p>----- ----- -----</p>	
<p>Battery Load Test</p> <p><i>Battery Load Test is in progress. This can be used to apply the battery test load during a battery test.</i></p>	<p>Combination of (BO1, BO2, BO3, BO4, BO5, BO6, BO7, BO8, BO9, BO10, BO11, BO12, BO13, BO14, L1, L2, L3, L4, L5, L6, L7, L8, L9, L10, L11, L12, L13, L14, L15, L16, L17, L18, L19, L20, V1, V2, V3, V4, V5, V6, V7, V8, V9, V10, V11, V12, V13, V14, V15, V16)</p>	<p>----- ----- -----</p>	
<p>Battery Test Pass</p> <p><i>Indicates whether the last battery test passed.</i></p>	<p>Combination of (BO1, BO2, BO3, BO4, BO5, BO6, BO7, BO8, BO9, BO10, BO11, BO12, BO13, BO14, L1, L2, L3, L4, L5, L6, L7, L8, L9, L10, L11, L12, L13, L14, L15, L16, L17, L18, L19, L20, V1, V2, V3, V4, V5, V6, V7, V8, V9, V10, V11, V12, V13, V14, V15, V16)</p>	<p>----- ----- -----</p>	
<p>Battery Test Fail</p> <p><i>Indicates whether the last battery test failed.</i></p>	<p>Combination of (BO1, BO2, BO3, BO4, BO5, BO6, BO7, BO8, BO9, BO10, BO11, BO12, BO13, BO14, L1, L2, L3, L4, L5, L6, L7, L8, L9, L10, L11, L12, L13, L14, L15, L16, L17, L18, L19, L20, V1, V2, V3, V4, V5, V6, V7, V8, V9, V10, V11, V12, V13, V14, V15, V16)</p>	<p>----- ----- -----</p>	
<p>Recovery Fail</p> <p><i>Indicates whether the battery failed to recover back to its pre-test voltage after last battery test.</i></p>	<p>Combination of (BO1, BO2, BO3, BO4, BO5, BO6, BO7, BO8, BO9, BO10, BO11, BO12, BO13, BO14, L1, L2, L3, L4, L5, L6, L7, L8, L9, L10, L11, L12, L13, L14, L15, L16, L17, L18, L19, L20, V1, V2, V3, V4, V5, V6, V7, V8, V9, V10, V11, V12, V13, V14, V15, V16)</p>	<p>----- ----- -----</p>	
<p>Ext. Power Good</p> <p><i>Indicates whether the external battery supply is ok.</i></p>	<p>Combination of (BO1, BO2, BO3, BO4, BO5, BO6, BO7, BO8, BO9, BO10, BO11, BO12, BO13, BO14, L1, L2, L3, L4, L5, L6, L7, L8, L9, L10, L11, L12, L13, L14, L15, L16, L17, L18, L19, L20, V1, V2, V3, V4, V5, V6, V7, V8, V9, V10, V11, V12, V13, V14, V15, V16)</p>	<p>----- ----- -----</p>	

Description	Range	Default	Setting
Battery Healthy <i>Indicates whether the current battery voltage is healthy</i>	Combination of (BO1, BO2, BO3, BO4, BO5, BO6, BO7, BO8, BO9, BO10, BO11, BO12, BO13, BO14, L1, L2, L3, L4, L5, L6, L7, L8, L9, L10, L11, L12, L13, L14, L15, L16, L17, L18, L19, L20, V1, V2, V3, V4, V5, V6, V7, V8, V9, V10, V11, V12, V13, V14, V15, V16)	----- ----- -----	
Capacitor Ready <i>Indicates whether the current capacitor status is ready to trip and close.</i>	Combination of (BO1, BO2, BO3, BO4, BO5, BO6, BO7, BO8, BO9, BO10, BO11, BO12, BO13, BO14, L1, L2, L3, L4, L5, L6, L7, L8, L9, L10, L11, L12, L13, L14, L15, L16, L17, L18, L19, L20, V1, V2, V3, V4, V5, V6, V7, V8, V9, V10, V11, V12, V13, V14, V15, V16)	----- ----- -----	
CapacitorSupplyFail <i>Indicates whether the current capacitor status is Supply Failed.</i>	Combination of (BO1, BO2, BO3, BO4, BO5, BO6, BO7, BO8, BO9, BO10, BO11, BO12, BO13, BO14, L1, L2, L3, L4, L5, L6, L7, L8, L9, L10, L11, L12, L13, L14, L15, L16, L17, L18, L19, L20, V1, V2, V3, V4, V5, V6, V7, V8, V9, V10, V11, V12, V13, V14, V15, V16)	----- ----- -----	
Capacitor Only Trip <i>Indicates whether the current capacitor status is Only Trip.</i>	Combination of (BO1, BO2, BO3, BO4, BO5, BO6, BO7, BO8, BO9, BO10, BO11, BO12, BO13, BO14, L1, L2, L3, L4, L5, L6, L7, L8, L9, L10, L11, L12, L13, L14, L15, L16, L17, L18, L19, L20, V1, V2, V3, V4, V5, V6, V7, V8, V9, V10, V11, V12, V13, V14, V15, V16)	----- ----- -----	
Capacitor DBI <i>Indicates whether the current capacitor status is DBI condition.</i>	Combination of (BO1, BO2, BO3, BO4, BO5, BO6, BO7, BO8, BO9, BO10, BO11, BO12, BO13, BO14, L1, L2, L3, L4, L5, L6, L7, L8, L9, L10, L11, L12, L13, L14, L15, L16, L17, L18, L19, L20, V1, V2, V3, V4, V5, V6, V7, V8, V9, V10, V11, V12, V13, V14, V15, V16)	----- ----- -----	
Cap Test Active <i>Capacitor Test is in progress.</i>	Combination of (BO1, BO2, BO3, BO4, BO5, BO6, BO7, BO8, BO9, BO10, BO11, BO12, BO13, BO14, L1, L2, L3, L4, L5, L6, L7, L8, L9, L10, L11, L12, L13, L14, L15, L16, L17, L18, L19, L20, V1, V2, V3, V4, V5, V6, V7, V8, V9, V10, V11, V12, V13, V14, V15, V16)	----- ----- -----	

Description	Range	Default	Setting
<p>Cap Test Pass</p> <p><i>Indicates whether the last capacitor test passed.</i></p>	<p>Combination of (BO1, BO2, BO3, BO4, BO5, BO6, BO7, BO8, BO9, BO10, BO11, BO12, BO13, BO14, L1, L2, L3, L4, L5, L6, L7, L8, L9, L10, L11, L12, L13, L14, L15, L16, L17, L18, L19, L20, V1, V2, V3, V4, V5, V6, V7, V8, V9, V10, V11, V12, V13, V14, V15, V16)</p>	<p>-----</p> <p>-----</p> <p>-----</p>	
<p>Cap Test Fail</p> <p><i>Indicates whether the last capacitor test failed.</i></p>	<p>Combination of (BO1, BO2, BO3, BO4, BO5, BO6, BO7, BO8, BO9, BO10, BO11, BO12, BO13, BO14, L1, L2, L3, L4, L5, L6, L7, L8, L9, L10, L11, L12, L13, L14, L15, L16, L17, L18, L19, L20, V1, V2, V3, V4, V5, V6, V7, V8, V9, V10, V11, V12, V13, V14, V15, V16)</p>	<p>-----</p> <p>-----</p> <p>-----</p>	
<p>Cap Recovery Fail</p> <p><i>Indicates whether the capacitor voltage failed to recover after the last capacitor test.</i></p>	<p>Combination of (BO1, BO2, BO3, BO4, BO5, BO6, BO7, BO8, BO9, BO10, BO11, BO12, BO13, BO14, L1, L2, L3, L4, L5, L6, L7, L8, L9, L10, L11, L12, L13, L14, L15, L16, L17, L18, L19, L20, V1, V2, V3, V4, V5, V6, V7, V8, V9, V10, V11, V12, V13, V14, V15, V16)</p>	<p>-----</p> <p>-----</p> <p>-----</p>	
<p>27Sag Pole1 SARFI</p> <p><i>Voltage has dropped below the defined SARFI level on Pole 1.</i></p>	<p>Combination of (BO1, BO2, BO3, BO4, BO5, BO6, BO7, BO8, BO9, BO10, BO11, BO12, BO13, BO14, L1, L2, L3, L4, L5, L6, L7, L8, L9, L10, L11, L12, L13, L14, L15, L16, L17, L18, L19, L20, V1, V2, V3, V4, V5, V6, V7, V8, V9, V10, V11, V12, V13, V14, V15, V16)</p>	<p>-----</p> <p>-----</p> <p>-----</p>	
<p>27Sag Pole2 SARFI</p> <p><i>Voltage has dropped below the defined SARFI level on Pole 2.</i></p>	<p>Combination of (BO1, BO2, BO3, BO4, BO5, BO6, BO7, BO8, BO9, BO10, BO11, BO12, BO13, BO14, L1, L2, L3, L4, L5, L6, L7, L8, L9, L10, L11, L12, L13, L14, L15, L16, L17, L18, L19, L20, V1, V2, V3, V4, V5, V6, V7, V8, V9, V10, V11, V12, V13, V14, V15, V16)</p>	<p>-----</p> <p>-----</p> <p>-----</p>	
<p>27Sag Pole3 SARFI</p> <p><i>Voltage has dropped below the defined SARFI level on Pole 3.</i></p>	<p>Combination of (BO1, BO2, BO3, BO4, BO5, BO6, BO7, BO8, BO9, BO10, BO11, BO12, BO13, BO14, L1, L2, L3, L4, L5, L6, L7, L8, L9, L10, L11, L12, L13, L14, L15, L16, L17, L18, L19, L20, V1, V2, V3, V4, V5, V6, V7, V8, V9, V10, V11, V12, V13, V14, V15, V16)</p>	<p>-----</p> <p>-----</p> <p>-----</p>	

Description	Range	Default	Setting
59Swell Pole1 SARFI <i>Voltage has risen above the defined SARFI level on Pole 1.</i>	Combination of (BO1, BO2, BO3, BO4, BO5, BO6, BO7, BO8, BO9, BO10, BO11, BO12, BO13, BO14, L1, L2, L3, L4, L5, L6, L7, L8, L9, L10, L11, L12, L13, L14, L15, L16, L17, L18, L19, L20, V1, V2, V3, V4, V5, V6, V7, V8, V9, V10, V11, V12, V13, V14, V15, V16)	----- ----- -----	
59Swell Pole2 SARFI <i>Voltage has risen above the defined SARFI level on Pole 2.</i>	Combination of (BO1, BO2, BO3, BO4, BO5, BO6, BO7, BO8, BO9, BO10, BO11, BO12, BO13, BO14, L1, L2, L3, L4, L5, L6, L7, L8, L9, L10, L11, L12, L13, L14, L15, L16, L17, L18, L19, L20, V1, V2, V3, V4, V5, V6, V7, V8, V9, V10, V11, V12, V13, V14, V15, V16)	----- ----- -----	
59Swell Pole3 SARFI <i>Voltage has risen above the defined SARFI level on Pole 3.</i>	Combination of (BO1, BO2, BO3, BO4, BO5, BO6, BO7, BO8, BO9, BO10, BO11, BO12, BO13, BO14, L1, L2, L3, L4, L5, L6, L7, L8, L9, L10, L11, L12, L13, L14, L15, L16, L17, L18, L19, L20, V1, V2, V3, V4, V5, V6, V7, V8, V9, V10, V11, V12, V13, V14, V15, V16)	----- ----- -----	
Phase A <i>A phase A element operated</i>	Combination of (BO1, BO2, BO3, BO4, BO5, BO6, BO7, BO8, BO9, BO10, BO11, BO12, BO13, BO14, L1, L2, L3, L4, L5, L6, L7, L8, L9, L10, L11, L12, L13, L14, L15, L16, L17, L18, L19, L20, V1, V2, V3, V4, V5, V6, V7, V8, V9, V10, V11, V12, V13, V14, V15, V16)	L1	
Phase B <i>A phase B element operated</i>	Combination of (BO1, BO2, BO3, BO4, BO5, BO6, BO7, BO8, BO9, BO10, BO11, BO12, BO13, BO14, L1, L2, L3, L4, L5, L6, L7, L8, L9, L10, L11, L12, L13, L14, L15, L16, L17, L18, L19, L20, V1, V2, V3, V4, V5, V6, V7, V8, V9, V10, V11, V12, V13, V14, V15, V16)	L2	
Phase C <i>A phase C element operated</i>	Combination of (BO1, BO2, BO3, BO4, BO5, BO6, BO7, BO8, BO9, BO10, BO11, BO12, BO13, BO14, L1, L2, L3, L4, L5, L6, L7, L8, L9, L10, L11, L12, L13, L14, L15, L16, L17, L18, L19, L20, V1, V2, V3, V4, V5, V6, V7, V8, V9, V10, V11, V12, V13, V14, V15, V16)	L3	

Description	Range	Default	Setting
<p>Forward P/F</p> <p><i>The Phase fault is in the forward direction. Note this output is presented EVEN when relay elements are set to be non-directional.</i></p>	<p>Combination of (BO1, BO2, BO3, BO4, BO5, BO6, BO7, BO8, BO9, BO10, BO11, BO12, BO13, BO14, L1, L2, L3, L4, L5, L6, L7, L8, L9, L10, L11, L12, L13, L14, L15, L16, L17, L18, L19, L20, V1, V2, V3, V4, V5, V6, V7, V8, V9, V10, V11, V12, V13, V14, V15, V16)</p>	<p>----- ----- -----</p>	
<p>Reverse P/F</p> <p><i>The Phase fault is in the reverse direction. Note this output is presented EVEN when relay elements are set to be non-directional.</i></p>	<p>Combination of (BO1, BO2, BO3, BO4, BO5, BO6, BO7, BO8, BO9, BO10, BO11, BO12, BO13, BO14, L1, L2, L3, L4, L5, L6, L7, L8, L9, L10, L11, L12, L13, L14, L15, L16, L17, L18, L19, L20, V1, V2, V3, V4, V5, V6, V7, V8, V9, V10, V11, V12, V13, V14, V15, V16)</p>	<p>----- ----- -----</p>	
<p>Forward E/F</p> <p><i>The fault is in the forward direction. Note this output is presented EVEN when relay elements are set to be non-directional.</i></p>	<p>Combination of (BO1, BO2, BO3, BO4, BO5, BO6, BO7, BO8, BO9, BO10, BO11, BO12, BO13, BO14, L1, L2, L3, L4, L5, L6, L7, L8, L9, L10, L11, L12, L13, L14, L15, L16, L17, L18, L19, L20, V1, V2, V3, V4, V5, V6, V7, V8, V9, V10, V11, V12, V13, V14, V15, V16)</p>	<p>----- ----- -----</p>	
<p>Reverse E/F</p> <p><i>The fault is in the reverse direction. Note this output is presented EVEN when relay elements are set to be non-directional.</i></p>	<p>Combination of (BO1, BO2, BO3, BO4, BO5, BO6, BO7, BO8, BO9, BO10, BO11, BO12, BO13, BO14, L1, L2, L3, L4, L5, L6, L7, L8, L9, L10, L11, L12, L13, L14, L15, L16, L17, L18, L19, L20, V1, V2, V3, V4, V5, V6, V7, V8, V9, V10, V11, V12, V13, V14, V15, V16)</p>	<p>----- ----- -----</p>	
<p>Forward SEF</p> <p><i>The fault is in the forward direction. Note this output is presented EVEN when relay elements are set to be non-directional.</i></p>	<p>Combination of (BO1, BO2, BO3, BO4, BO5, BO6, BO7, BO8, BO9, BO10, BO11, BO12, BO13, BO14, L1, L2, L3, L4, L5, L6, L7, L8, L9, L10, L11, L12, L13, L14, L15, L16, L17, L18, L19, L20, V1, V2, V3, V4, V5, V6, V7, V8, V9, V10, V11, V12, V13, V14, V15, V16)</p>	<p>----- ----- -----</p>	
<p>Reverse SEF</p> <p><i>The fault is in the reverse direction. Note this output is presented EVEN when relay elements are set to be non-directional.</i></p>	<p>Combination of (BO1, BO2, BO3, BO4, BO5, BO6, BO7, BO8, BO9, BO10, BO11, BO12, BO13, BO14, L1, L2, L3, L4, L5, L6, L7, L8, L9, L10, L11, L12, L13, L14, L15, L16, L17, L18, L19, L20, V1, V2, V3, V4, V5, V6, V7, V8, V9, V10, V11, V12, V13, V14, V15, V16)</p>	<p>----- ----- -----</p>	

Description	Range	Default	Setting
<p>Close CB Blocked</p> <p><i>Indicates that the Close CB control is blocked by its interlocking logic.</i></p>	<p>Combination of (BO1, BO2, BO3, BO4, BO5, BO6, BO7, BO8, BO9, BO10, BO11, BO12, BO13, BO14, L1, L2, L3, L4, L5, L6, L7, L8, L9, L10, L11, L12, L13, L14, L15, L16, L17, L18, L19, L20, V1, V2, V3, V4, V5, V6, V7, V8, V9, V10, V11, V12, V13, V14, V15, V16)</p>	<p>-----</p> <p>-----</p> <p>-----</p>	
<p>Open CB</p> <p><i>Open pulse due to Manual Open being issued.</i></p>	<p>Combination of (BO1, BO2, BO3, BO4, BO5, BO6, BO7, BO8, BO9, BO10, BO11, BO12, BO13, BO14, L1, L2, L3, L4, L5, L6, L7, L8, L9, L10, L11, L12, L13, L14, L15, L16, L17, L18, L19, L20, V1, V2, V3, V4, V5, V6, V7, V8, V9, V10, V11, V12, V13, V14, V15, V16)</p>	<p>-----</p> <p>-----</p> <p>-----</p>	
<p>CB Alarm</p> <p><i>Indicates the CB is either in an illegal state or is stuck neither open or closed.</i></p>	<p>Combination of (BO1, BO2, BO3, BO4, BO5, BO6, BO7, BO8, BO9, BO10, BO11, BO12, BO13, BO14, L1, L2, L3, L4, L5, L6, L7, L8, L9, L10, L11, L12, L13, L14, L15, L16, L17, L18, L19, L20, V1, V2, V3, V4, V5, V6, V7, V8, V9, V10, V11, V12, V13, V14, V15, V16)</p>	<p>-----</p> <p>-----</p> <p>-----</p>	
<p>CB Closed</p> <p><i>Indicates that the circuit breaker is in the closed position.</i></p>	<p>Combination of (BO1, BO2, BO3, BO4, BO5, BO6, BO7, BO8, BO9, BO10, BO11, BO12, BO13, BO14, L1, L2, L3, L4, L5, L6, L7, L8, L9, L10, L11, L12, L13, L14, L15, L16, L17, L18, L19, L20, V1, V2, V3, V4, V5, V6, V7, V8, V9, V10, V11, V12, V13, V14, V15, V16)</p>	<p>-----</p> <p>-----</p> <p>-----</p>	
<p>CB Open</p> <p><i>Indicates that the circuit breaker is in the open position.</i></p>	<p>Combination of (BO1, BO2, BO3, BO4, BO5, BO6, BO7, BO8, BO9, BO10, BO11, BO12, BO13, BO14, L1, L2, L3, L4, L5, L6, L7, L8, L9, L10, L11, L12, L13, L14, L15, L16, L17, L18, L19, L20, V1, V2, V3, V4, V5, V6, V7, V8, V9, V10, V11, V12, V13, V14, V15, V16)</p>	<p>-----</p> <p>-----</p> <p>-----</p>	
<p>Manual Close CB</p> <p><i>Close pulse due to Manual close being issued</i></p>	<p>Combination of (BO1, BO2, BO3, BO4, BO5, BO6, BO7, BO8, BO9, BO10, BO11, BO12, BO13, BO14, L1, L2, L3, L4, L5, L6, L7, L8, L9, L10, L11, L12, L13, L14, L15, L16, L17, L18, L19, L20, V1, V2, V3, V4, V5, V6, V7, V8, V9, V10, V11, V12, V13, V14, V15, V16)</p>	<p>-----</p> <p>-----</p> <p>-----</p>	

Description	Range	Default	Setting
79 AR Close CB <i>Close pulse due to auto-reclose sequence</i>	Combination of (BO1, BO2, BO3, BO4, BO5, BO6, BO7, BO8, BO9, BO10, BO11, BO12, BO13, BO14, L1, L2, L3, L4, L5, L6, L7, L8, L9, L10, L11, L12, L13, L14, L15, L16, L17, L18, L19, L20, V1, V2, V3, V4, V5, V6, V7, V8, V9, V10, V11, V12, V13, V14, V15, V16)	----- ----- -----	
79 Trip & Reclose <i>Indicates the Trip & Reclose sequence being performed</i>	Combination of (BO1, BO2, BO3, BO4, BO5, BO6, BO7, BO8, BO9, BO10, BO11, BO12, BO13, BO14, L1, L2, L3, L4, L5, L6, L7, L8, L9, L10, L11, L12, L13, L14, L15, L16, L17, L18, L19, L20, V1, V2, V3, V4, V5, V6, V7, V8, V9, V10, V11, V12, V13, V14, V15, V16)	----- ----- -----	
79 Trip & Lockout <i>Indicates the Trip & Lockout sequence being performed</i>	Combination of (BO1, BO2, BO3, BO4, BO5, BO6, BO7, BO8, BO9, BO10, BO11, BO12, BO13, BO14, L1, L2, L3, L4, L5, L6, L7, L8, L9, L10, L11, L12, L13, L14, L15, L16, L17, L18, L19, L20, V1, V2, V3, V4, V5, V6, V7, V8, V9, V10, V11, V12, V13, V14, V15, V16)	----- ----- -----	
79 Lockout <i>Indicates the auto-recloser is in the Lockout state</i>	Combination of (BO1, BO2, BO3, BO4, BO5, BO6, BO7, BO8, BO9, BO10, BO11, BO12, BO13, BO14, L1, L2, L3, L4, L5, L6, L7, L8, L9, L10, L11, L12, L13, L14, L15, L16, L17, L18, L19, L20, V1, V2, V3, V4, V5, V6, V7, V8, V9, V10, V11, V12, V13, V14, V15, V16)	----- ----- -----	
79 Out Of Service <i>Indicates the auto-recloser is out of service</i>	Combination of (BO1, BO2, BO3, BO4, BO5, BO6, BO7, BO8, BO9, BO10, BO11, BO12, BO13, BO14, L1, L2, L3, L4, L5, L6, L7, L8, L9, L10, L11, L12, L13, L14, L15, L16, L17, L18, L19, L20, V1, V2, V3, V4, V5, V6, V7, V8, V9, V10, V11, V12, V13, V14, V15, V16)	----- ----- -----	
79 In Service <i>Indicates the auto-recloser is in service</i>	Combination of (BO1, BO2, BO3, BO4, BO5, BO6, BO7, BO8, BO9, BO10, BO11, BO12, BO13, BO14, L1, L2, L3, L4, L5, L6, L7, L8, L9, L10, L11, L12, L13, L14, L15, L16, L17, L18, L19, L20, V1, V2, V3, V4, V5, V6, V7, V8, V9, V10, V11, V12, V13, V14, V15, V16)	----- ----- -----	

Description	Range	Default	Setting
<p>79 In Progress <i>Indicates an auto-reclose sequence is in progress</i></p>	<p>Combination of (BO1, BO2, BO3, BO4, BO5, BO6, BO7, BO8, BO9, BO10, BO11, BO12, BO13, BO14, L1, L2, L3, L4, L5, L6, L7, L8, L9, L10, L11, L12, L13, L14, L15, L16, L17, L18, L19, L20, V1, V2, V3, V4, V5, V6, V7, V8, V9, V10, V11, V12, V13, V14, V15, V16)</p>	<p>----- ----- -----</p>	
<p>79 Block Extern <i>Indicates that Extern for the current shot has been selected to be delayed. (This may be used to block external tripping elements in the same way as the internal protection elements are blocked to achieve Instantaneous / Delayed operation.)</i></p>	<p>Combination of (BO1, BO2, BO3, BO4, BO5, BO6, BO7, BO8, BO9, BO10, BO11, BO12, BO13, BO14, L1, L2, L3, L4, L5, L6, L7, L8, L9, L10, L11, L12, L13, L14, L15, L16, L17, L18, L19, L20, V1, V2, V3, V4, V5, V6, V7, V8, V9, V10, V11, V12, V13, V14, V15, V16)</p>	<p>----- ----- -----</p>	
<p>79 CB Fail To Close <i>Indicates the CB was not closed at the end of the Close Pulse</i></p>	<p>Combination of (BO1, BO2, BO3, BO4, BO5, BO6, BO7, BO8, BO9, BO10, BO11, BO12, BO13, BO14, L1, L2, L3, L4, L5, L6, L7, L8, L9, L10, L11, L12, L13, L14, L15, L16, L17, L18, L19, L20, V1, V2, V3, V4, V5, V6, V7, V8, V9, V10, V11, V12, V13, V14, V15, V16)</p>	<p>----- ----- -----</p>	
<p>79 Close Onto Fault <i>Indicates an element starter or trip operated during the Close Pulse</i></p>	<p>Combination of (BO1, BO2, BO3, BO4, BO5, BO6, BO7, BO8, BO9, BO10, BO11, BO12, BO13, BO14, L1, L2, L3, L4, L5, L6, L7, L8, L9, L10, L11, L12, L13, L14, L15, L16, L17, L18, L19, L20, V1, V2, V3, V4, V5, V6, V7, V8, V9, V10, V11, V12, V13, V14, V15, V16)</p>	<p>----- ----- -----</p>	
<p>79 Successful AR <i>Indicates that after a reclose and at the end of the Reclaim time the CB was closed and there were no auto-reclose trip elements operated. (This is issued for 2 secs)</i></p>	<p>Combination of (BO1, BO2, BO3, BO4, BO5, BO6, BO7, BO8, BO9, BO10, BO11, BO12, BO13, BO14, L1, L2, L3, L4, L5, L6, L7, L8, L9, L10, L11, L12, L13, L14, L15, L16, L17, L18, L19, L20, V1, V2, V3, V4, V5, V6, V7, V8, V9, V10, V11, V12, V13, V14, V15, V16)</p>	<p>----- ----- -----</p>	
<p>Successful Man Close <i>Indicates that after a manual close and at the end of the Reclaim time the CB was closed and there were no auto-reclose trip elements operated. (This is issued for 2 secs)</i></p>	<p>Combination of (BO1, BO2, BO3, BO4, BO5, BO6, BO7, BO8, BO9, BO10, BO11, BO12, BO13, BO14, L1, L2, L3, L4, L5, L6, L7, L8, L9, L10, L11, L12, L13, L14, L15, L16, L17, L18, L19, L20, V1, V2, V3, V4, V5, V6, V7, V8, V9, V10, V11, V12, V13, V14, V15, V16)</p>	<p>----- ----- -----</p>	

Description	Range	Default	Setting
25 Live Line <i>Indicates that the Line is energised</i>	Combination of (BO1, BO2, BO3, BO4, BO5, BO6, BO7, BO8, BO9, BO10, BO11, BO12, BO13, BO14, L1, L2, L3, L4, L5, L6, L7, L8, L9, L10, L11, L12, L13, L14, L15, L16, L17, L18, L19, L20, V1, V2, V3, V4, V5, V6, V7, V8, V9, V10, V11, V12, V13, V14, V15, V16)	----- ----- -----	
25 Live Bus <i>Indicates that the Bus is energised</i>	Combination of (BO1, BO2, BO3, BO4, BO5, BO6, BO7, BO8, BO9, BO10, BO11, BO12, BO13, BO14, L1, L2, L3, L4, L5, L6, L7, L8, L9, L10, L11, L12, L13, L14, L15, L16, L17, L18, L19, L20, V1, V2, V3, V4, V5, V6, V7, V8, V9, V10, V11, V12, V13, V14, V15, V16)	----- ----- -----	
25 Line U/V <i>Indicates that an undervoltage condition exists on the Line</i>	Combination of (BO1, BO2, BO3, BO4, BO5, BO6, BO7, BO8, BO9, BO10, BO11, BO12, BO13, BO14, L1, L2, L3, L4, L5, L6, L7, L8, L9, L10, L11, L12, L13, L14, L15, L16, L17, L18, L19, L20, V1, V2, V3, V4, V5, V6, V7, V8, V9, V10, V11, V12, V13, V14, V15, V16)	----- ----- -----	
25 Bus U/V <i>Indicates that an undervoltage condition exists on the Bus</i>	Combination of (BO1, BO2, BO3, BO4, BO5, BO6, BO7, BO8, BO9, BO10, BO11, BO12, BO13, BO14, L1, L2, L3, L4, L5, L6, L7, L8, L9, L10, L11, L12, L13, L14, L15, L16, L17, L18, L19, L20, V1, V2, V3, V4, V5, V6, V7, V8, V9, V10, V11, V12, V13, V14, V15, V16)	----- ----- -----	
25 Diff Voltage <i>Indicates that a Voltage Differential exists</i>	Combination of (BO1, BO2, BO3, BO4, BO5, BO6, BO7, BO8, BO9, BO10, BO11, BO12, BO13, BO14, L1, L2, L3, L4, L5, L6, L7, L8, L9, L10, L11, L12, L13, L14, L15, L16, L17, L18, L19, L20, V1, V2, V3, V4, V5, V6, V7, V8, V9, V10, V11, V12, V13, V14, V15, V16)	----- ----- -----	
25 Voltage Check <i>Indicates that all the Voltage Check conditions are met</i>	Combination of (BO1, BO2, BO3, BO4, BO5, BO6, BO7, BO8, BO9, BO10, BO11, BO12, BO13, BO14, L1, L2, L3, L4, L5, L6, L7, L8, L9, L10, L11, L12, L13, L14, L15, L16, L17, L18, L19, L20, V1, V2, V3, V4, V5, V6, V7, V8, V9, V10, V11, V12, V13, V14, V15, V16)	----- ----- -----	

Description	Range	Default	Setting
25 In Sync <i>Indicates that the system is In Sync</i>	Combination of (BO1, BO2, BO3, BO4, BO5, BO6, BO7, BO8, BO9, BO10, BO11, BO12, BO13, BO14, L1, L2, L3, L4, L5, L6, L7, L8, L9, L10, L11, L12, L13, L14, L15, L16, L17, L18, L19, L20, V1, V2, V3, V4, V5, V6, V7, V8, V9, V10, V11, V12, V13, V14, V15, V16)	----- ----- -----	
25 CS In Progress <i>Indicates that Check Sync is In Progress</i>	Combination of (BO1, BO2, BO3, BO4, BO5, BO6, BO7, BO8, BO9, BO10, BO11, BO12, BO13, BO14, L1, L2, L3, L4, L5, L6, L7, L8, L9, L10, L11, L12, L13, L14, L15, L16, L17, L18, L19, L20, V1, V2, V3, V4, V5, V6, V7, V8, V9, V10, V11, V12, V13, V14, V15, V16)	----- ----- -----	
25 SS In Progress <i>Indicates that System Sync is In Progress</i>	Combination of (BO1, BO2, BO3, BO4, BO5, BO6, BO7, BO8, BO9, BO10, BO11, BO12, BO13, BO14, L1, L2, L3, L4, L5, L6, L7, L8, L9, L10, L11, L12, L13, L14, L15, L16, L17, L18, L19, L20, V1, V2, V3, V4, V5, V6, V7, V8, V9, V10, V11, V12, V13, V14, V15, V16)	----- ----- -----	
25 COZ In Progress <i>Indicates that Close On Zero is In Progress</i>	Combination of (BO1, BO2, BO3, BO4, BO5, BO6, BO7, BO8, BO9, BO10, BO11, BO12, BO13, BO14, L1, L2, L3, L4, L5, L6, L7, L8, L9, L10, L11, L12, L13, L14, L15, L16, L17, L18, L19, L20, V1, V2, V3, V4, V5, V6, V7, V8, V9, V10, V11, V12, V13, V14, V15, V16)	----- ----- -----	
25 System Split LO <i>Indicates that a System Split LO condition exists</i>	Combination of (BO1, BO2, BO3, BO4, BO5, BO6, BO7, BO8, BO9, BO10, BO11, BO12, BO13, BO14, L1, L2, L3, L4, L5, L6, L7, L8, L9, L10, L11, L12, L13, L14, L15, L16, L17, L18, L19, L20, V1, V2, V3, V4, V5, V6, V7, V8, V9, V10, V11, V12, V13, V14, V15, V16)	----- ----- -----	
Hot Line Working <i>Indicates that Hot LineWorking functionality has been selected</i>	Combination of (BO1, BO2, BO3, BO4, BO5, BO6, BO7, BO8, BO9, BO10, BO11, BO12, BO13, BO14, L1, L2, L3, L4, L5, L6, L7, L8, L9, L10, L11, L12, L13, L14, L15, L16, L17, L18, L19, L20, V1, V2, V3, V4, V5, V6, V7, V8, V9, V10, V11, V12, V13, V14, V15, V16)	----- ----- -----	

Description	Range	Default	Setting
<p>Inst Prot'n Out <i>Indicates that the protection elements selected to be Instantaneous elements are switched out</i></p>	<p>Combination of (BO1, BO2, BO3, BO4, BO5, BO6, BO7, BO8, BO9, BO10, BO11, BO12, BO13, BO14, L1, L2, L3, L4, L5, L6, L7, L8, L9, L10, L11, L12, L13, L14, L15, L16, L17, L18, L19, L20, V1, V2, V3, V4, V5, V6, V7, V8, V9, V10, V11, V12, V13, V14, V15, V16)</p>	<p>----- ----- -----</p>	
<p>E/F Out <i>Indicates that the instantaneous protection elements are switched out.</i></p>	<p>Combination of (BO1, BO2, BO3, BO4, BO5, BO6, BO7, BO8, BO9, BO10, BO11, BO12, BO13, BO14, L1, L2, L3, L4, L5, L6, L7, L8, L9, L10, L11, L12, L13, L14, L15, L16, L17, L18, L19, L20, V1, V2, V3, V4, V5, V6, V7, V8, V9, V10, V11, V12, V13, V14, V15, V16)</p>	<p>----- ----- -----</p>	
<p>SEF Out <i>Indicates that the SEF protection elements are switched out</i></p>	<p>Combination of (BO1, BO2, BO3, BO4, BO5, BO6, BO7, BO8, BO9, BO10, BO11, BO12, BO13, BO14, L1, L2, L3, L4, L5, L6, L7, L8, L9, L10, L11, L12, L13, L14, L15, L16, L17, L18, L19, L20, V1, V2, V3, V4, V5, V6, V7, V8, V9, V10, V11, V12, V13, V14, V15, V16)</p>	<p>----- ----- -----</p>	
<p>New Wave Stored <i>The waveform recorder has stored new information Note: this is a pulsed output</i></p>	<p>Combination of (BO1, BO2, BO3, BO4, BO5, BO6, BO7, BO8, BO9, BO10, BO11, BO12, BO13, BO14, L1, L2, L3, L4, L5, L6, L7, L8, L9, L10, L11, L12, L13, L14, L15, L16, L17, L18, L19, L20, V1, V2, V3, V4, V5, V6, V7, V8, V9, V10, V11, V12, V13, V14, V15, V16)</p>	<p>----- ----- -----</p>	
<p>New Fault Stored <i>The fault recorder has stored new information Note: this is a pulsed output</i></p>	<p>Combination of (BO1, BO2, BO3, BO4, BO5, BO6, BO7, BO8, BO9, BO10, BO11, BO12, BO13, BO14, L1, L2, L3, L4, L5, L6, L7, L8, L9, L10, L11, L12, L13, L14, L15, L16, L17, L18, L19, L20, V1, V2, V3, V4, V5, V6, V7, V8, V9, V10, V11, V12, V13, V14, V15, V16)</p>	<p>----- ----- -----</p>	
<p>Man Override Sync <i>Selects which inputs will bypass the Synchronisation check of the Manual Close</i></p>	<p>Combination of (BO1, BO2, BO3, BO4, BO5, BO6, BO7, BO8, BO9, BO10, BO11, BO12, BO13, BO14, L1, L2, L3, L4, L5, L6, L7, L8, L9, L10, L11, L12, L13, L14, L15, L16, L17, L18, L19, L20, V1, V2, V3, V4, V5, V6, V7, V8, V9, V10, V11, V12, V13, V14, V15, V16)</p>	<p>----- ----- -----</p>	

Description	Range	Default	Setting
79 Override Sync <i>Selects which inputs will bypass the Synchronisation check of the Auto-recloser</i>	Combination of (BO1, BO2, BO3, BO4, BO5, BO6, BO7, BO8, BO9, BO10, BO11, BO12, BO13, BO14, L1, L2, L3, L4, L5, L6, L7, L8, L9, L10, L11, L12, L13, L14, L15, L16, L17, L18, L19, L20, V1, V2, V3, V4, V5, V6, V7, V8, V9, V10, V11, V12, V13, V14, V15, V16)	----- ----- -----	
Active Exp Pulse	Combination of (BO1, BO2, BO3, BO4, BO5, BO6, BO7, BO8, BO9, BO10, BO11, BO12, BO13, BO14, L1, L2, L3, L4, L5, L6, L7, L8, L9, L10, L11, L12, L13, L14, L15, L16, L17, L18, L19, L20, V1, V2, V3, V4, V5, V6, V7, V8, V9, V10, V11, V12, V13, V14, V15, V16)	----- ----- -----	
Active Imp Pulse	Combination of (BO1, BO2, BO3, BO4, BO5, BO6, BO7, BO8, BO9, BO10, BO11, BO12, BO13, BO14, L1, L2, L3, L4, L5, L6, L7, L8, L9, L10, L11, L12, L13, L14, L15, L16, L17, L18, L19, L20, V1, V2, V3, V4, V5, V6, V7, V8, V9, V10, V11, V12, V13, V14, V15, V16)	----- ----- -----	
Reactive Exp Pulse	Combination of (BO1, BO2, BO3, BO4, BO5, BO6, BO7, BO8, BO9, BO10, BO11, BO12, BO13, BO14, L1, L2, L3, L4, L5, L6, L7, L8, L9, L10, L11, L12, L13, L14, L15, L16, L17, L18, L19, L20, V1, V2, V3, V4, V5, V6, V7, V8, V9, V10, V11, V12, V13, V14, V15, V16)	----- ----- -----	
Reactive Imp Pulse	Combination of (BO1, BO2, BO3, BO4, BO5, BO6, BO7, BO8, BO9, BO10, BO11, BO12, BO13, BO14, L1, L2, L3, L4, L5, L6, L7, L8, L9, L10, L11, L12, L13, L14, L15, L16, L17, L18, L19, L20, V1, V2, V3, V4, V5, V6, V7, V8, V9, V10, V11, V12, V13, V14, V15, V16)	----- ----- -----	
Out Of Service Mode <i>Indicates the relay is in Out Of Service Mode</i>	Combination of (BO1, BO2, BO3, BO4, BO5, BO6, BO7, BO8, BO9, BO10, BO11, BO12, BO13, BO14, L1, L2, L3, L4, L5, L6, L7, L8, L9, L10, L11, L12, L13, L14, L15, L16, L17, L18, L19, L20, V1, V2, V3, V4, V5, V6, V7, V8, V9, V10, V11, V12, V13, V14, V15, V16)	----- ----- -----	

Description	Range	Default	Setting
Local Mode <i>Indicates the relay is in Local Mode</i>	Combination of (BO1, BO2, BO3, BO4, BO5, BO6, BO7, BO8, BO9, BO10, BO11, BO12, BO13, BO14, L1, L2, L3, L4, L5, L6, L7, L8, L9, L10, L11, L12, L13, L14, L15, L16, L17, L18, L19, L20, V1, V2, V3, V4, V5, V6, V7, V8, V9, V10, V11, V12, V13, V14, V15, V16)	----- ----- -----	
Remote Mode <i>Indicates the relay is in Remote Mode</i>	Combination of (BO1, BO2, BO3, BO4, BO5, BO6, BO7, BO8, BO9, BO10, BO11, BO12, BO13, BO14, L1, L2, L3, L4, L5, L6, L7, L8, L9, L10, L11, L12, L13, L14, L15, L16, L17, L18, L19, L20, V1, V2, V3, V4, V5, V6, V7, V8, V9, V10, V11, V12, V13, V14, V15, V16)	----- ----- -----	
BI 1 Operated <i>DC Binary Input 1 has operated</i>	Combination of (BO1, BO2, BO3, BO4, BO5, BO6, BO7, BO8, BO9, BO10, BO11, BO12, BO13, BO14, L1, L2, L3, L4, L5, L6, L7, L8, L9, L10, L11, L12, L13, L14, L15, L16, L17, L18, L19, L20, V1, V2, V3, V4, V5, V6, V7, V8, V9, V10, V11, V12, V13, V14, V15, V16)	----- ----- -----	
BI 2 Operated <i>DC Binary Input 2 has operated</i>	Combination of (BO1, BO2, BO3, BO4, BO5, BO6, BO7, BO8, BO9, BO10, BO11, BO12, BO13, BO14, L1, L2, L3, L4, L5, L6, L7, L8, L9, L10, L11, L12, L13, L14, L15, L16, L17, L18, L19, L20, V1, V2, V3, V4, V5, V6, V7, V8, V9, V10, V11, V12, V13, V14, V15, V16)	----- ----- -----	
BI 3 Operated <i>DC Binary Input 3 has operated</i>	Combination of (BO1, BO2, BO3, BO4, BO5, BO6, BO7, BO8, BO9, BO10, BO11, BO12, BO13, BO14, L1, L2, L3, L4, L5, L6, L7, L8, L9, L10, L11, L12, L13, L14, L15, L16, L17, L18, L19, L20, V1, V2, V3, V4, V5, V6, V7, V8, V9, V10, V11, V12, V13, V14, V15, V16)	----- ----- -----	
BI 4 Operated <i>DC Binary Input 4 has operated</i>	Combination of (BO1, BO2, BO3, BO4, BO5, BO6, BO7, BO8, BO9, BO10, BO11, BO12, BO13, BO14, L1, L2, L3, L4, L5, L6, L7, L8, L9, L10, L11, L12, L13, L14, L15, L16, L17, L18, L19, L20, V1, V2, V3, V4, V5, V6, V7, V8, V9, V10, V11, V12, V13, V14, V15, V16)	----- ----- -----	

Description	Range	Default	Setting
BI 5 Operated <i>DC Binary Input 5 has operated</i>	Combination of (BO1, BO2, BO3, BO4, BO5, BO6, BO7, BO8, BO9, BO10, BO11, BO12, BO13, BO14, L1, L2, L3, L4, L5, L6, L7, L8, L9, L10, L11, L12, L13, L14, L15, L16, L17, L18, L19, L20, V1, V2, V3, V4, V5, V6, V7, V8, V9, V10, V11, V12, V13, V14, V15, V16)	----- ----- -----	
BI 6 Operated <i>DC Binary Input 6 has operated</i>	Combination of (BO1, BO2, BO3, BO4, BO5, BO6, BO7, BO8, BO9, BO10, BO11, BO12, BO13, BO14, L1, L2, L3, L4, L5, L6, L7, L8, L9, L10, L11, L12, L13, L14, L15, L16, L17, L18, L19, L20, V1, V2, V3, V4, V5, V6, V7, V8, V9, V10, V11, V12, V13, V14, V15, V16)	----- ----- -----	
BI 7 Operated <i>DC Binary Input 7 has operated</i>	Combination of (BO1, BO2, BO3, BO4, BO5, BO6, BO7, BO8, BO9, BO10, BO11, BO12, BO13, BO14, L1, L2, L3, L4, L5, L6, L7, L8, L9, L10, L11, L12, L13, L14, L15, L16, L17, L18, L19, L20, V1, V2, V3, V4, V5, V6, V7, V8, V9, V10, V11, V12, V13, V14, V15, V16)	----- ----- -----	
BI 8 Operated <i>DC Binary Input 8 has operated</i>	Combination of (BO1, BO2, BO3, BO4, BO5, BO6, BO7, BO8, BO9, BO10, BO11, BO12, BO13, BO14, L1, L2, L3, L4, L5, L6, L7, L8, L9, L10, L11, L12, L13, L14, L15, L16, L17, L18, L19, L20, V1, V2, V3, V4, V5, V6, V7, V8, V9, V10, V11, V12, V13, V14, V15, V16)	----- ----- -----	
BI 9 Operated <i>DC Binary Input 9 has operated</i>	Combination of (BO1, BO2, BO3, BO4, BO5, BO6, BO7, BO8, BO9, BO10, BO11, BO12, BO13, BO14, L1, L2, L3, L4, L5, L6, L7, L8, L9, L10, L11, L12, L13, L14, L15, L16, L17, L18, L19, L20, V1, V2, V3, V4, V5, V6, V7, V8, V9, V10, V11, V12, V13, V14, V15, V16)	----- ----- -----	
BI 10 Operated <i>DC Binary Input 10 has operated</i>	Combination of (BO1, BO2, BO3, BO4, BO5, BO6, BO7, BO8, BO9, BO10, BO11, BO12, BO13, BO14, L1, L2, L3, L4, L5, L6, L7, L8, L9, L10, L11, L12, L13, L14, L15, L16, L17, L18, L19, L20, V1, V2, V3, V4, V5, V6, V7, V8, V9, V10, V11, V12, V13, V14, V15, V16)	----- ----- -----	

Description	Range	Default	Setting
BI 11 Operated <i>DC Binary Input 11 has operated</i>	Combination of (BO1, BO2, BO3, BO4, BO5, BO6, BO7, BO8, BO9, BO10, BO11, BO12, BO13, BO14, L1, L2, L3, L4, L5, L6, L7, L8, L9, L10, L11, L12, L13, L14, L15, L16, L17, L18, L19, L20, V1, V2, V3, V4, V5, V6, V7, V8, V9, V10, V11, V12, V13, V14, V15, V16)	----- ----- -----	
BI 12 Operated <i>DC Binary Input 12 has operated</i>	Combination of (BO1, BO2, BO3, BO4, BO5, BO6, BO7, BO8, BO9, BO10, BO11, BO12, BO13, BO14, L1, L2, L3, L4, L5, L6, L7, L8, L9, L10, L11, L12, L13, L14, L15, L16, L17, L18, L19, L20, V1, V2, V3, V4, V5, V6, V7, V8, V9, V10, V11, V12, V13, V14, V15, V16)	----- ----- -----	
BI 13 Operated <i>DC Binary Input 13 has operated</i>	Combination of (BO1, BO2, BO3, BO4, BO5, BO6, BO7, BO8, BO9, BO10, BO11, BO12, BO13, BO14, L1, L2, L3, L4, L5, L6, L7, L8, L9, L10, L11, L12, L13, L14, L15, L16, L17, L18, L19, L20, V1, V2, V3, V4, V5, V6, V7, V8, V9, V10, V11, V12, V13, V14, V15, V16)	----- ----- -----	
BI 14 Operated <i>DC Binary Input 14 has operated</i>	Combination of (BO1, BO2, BO3, BO4, BO5, BO6, BO7, BO8, BO9, BO10, BO11, BO12, BO13, BO14, L1, L2, L3, L4, L5, L6, L7, L8, L9, L10, L11, L12, L13, L14, L15, L16, L17, L18, L19, L20, V1, V2, V3, V4, V5, V6, V7, V8, V9, V10, V11, V12, V13, V14, V15, V16)	----- ----- -----	
BI 15 Operated <i>DC Binary Input 15 has operated</i>	Combination of (BO1, BO2, BO3, BO4, BO5, BO6, BO7, BO8, BO9, BO10, BO11, BO12, BO13, BO14, L1, L2, L3, L4, L5, L6, L7, L8, L9, L10, L11, L12, L13, L14, L15, L16, L17, L18, L19, L20, V1, V2, V3, V4, V5, V6, V7, V8, V9, V10, V11, V12, V13, V14, V15, V16)	----- ----- -----	
BI 16 Operated <i>DC Binary Input 16 has operated</i>	Combination of (BO1, BO2, BO3, BO4, BO5, BO6, BO7, BO8, BO9, BO10, BO11, BO12, BO13, BO14, L1, L2, L3, L4, L5, L6, L7, L8, L9, L10, L11, L12, L13, L14, L15, L16, L17, L18, L19, L20, V1, V2, V3, V4, V5, V6, V7, V8, V9, V10, V11, V12, V13, V14, V15, V16)	----- ----- -----	

Description	Range	Default	Setting
BI 17 Operated <i>DC Binary Input 17 has operated</i>	Combination of (BO1, BO2, BO3, BO4, BO5, BO6, BO7, BO8, BO9, BO10, BO11, BO12, BO13, BO14, L1, L2, L3, L4, L5, L6, L7, L8, L9, L10, L11, L12, L13, L14, L15, L16, L17, L18, L19, L20, V1, V2, V3, V4, V5, V6, V7, V8, V9, V10, V11, V12, V13, V14, V15, V16)	----- ----- -----	
BI 18 Operated <i>DC Binary Input 18 has operated</i>	Combination of (BO1, BO2, BO3, BO4, BO5, BO6, BO7, BO8, BO9, BO10, BO11, BO12, BO13, BO14, L1, L2, L3, L4, L5, L6, L7, L8, L9, L10, L11, L12, L13, L14, L15, L16, L17, L18, L19, L20, V1, V2, V3, V4, V5, V6, V7, V8, V9, V10, V11, V12, V13, V14, V15, V16)	----- ----- -----	
BI 19 Operated <i>DC Binary Input 19 has operated</i>	Combination of (BO1, BO2, BO3, BO4, BO5, BO6, BO7, BO8, BO9, BO10, BO11, BO12, BO13, BO14, L1, L2, L3, L4, L5, L6, L7, L8, L9, L10, L11, L12, L13, L14, L15, L16, L17, L18, L19, L20, V1, V2, V3, V4, V5, V6, V7, V8, V9, V10, V11, V12, V13, V14, V15, V16)	----- ----- -----	
BI 20 Operated <i>DC Binary Input 20 has operated</i>	Combination of (BO1, BO2, BO3, BO4, BO5, BO6, BO7, BO8, BO9, BO10, BO11, BO12, BO13, BO14, L1, L2, L3, L4, L5, L6, L7, L8, L9, L10, L11, L12, L13, L14, L15, L16, L17, L18, L19, L20, V1, V2, V3, V4, V5, V6, V7, V8, V9, V10, V11, V12, V13, V14, V15, V16)	----- ----- -----	
BI 21 Operated <i>DC Binary Input 21 has operated</i>	Combination of (BO1, BO2, BO3, BO4, BO5, BO6, BO7, BO8, BO9, BO10, BO11, BO12, BO13, BO14, L1, L2, L3, L4, L5, L6, L7, L8, L9, L10, L11, L12, L13, L14, L15, L16, L17, L18, L19, L20, V1, V2, V3, V4, V5, V6, V7, V8, V9, V10, V11, V12, V13, V14, V15, V16)	----- ----- -----	
BI 22 Operated <i>DC Binary Input 22 has operated</i>	Combination of (BO1, BO2, BO3, BO4, BO5, BO6, BO7, BO8, BO9, BO10, BO11, BO12, BO13, BO14, L1, L2, L3, L4, L5, L6, L7, L8, L9, L10, L11, L12, L13, L14, L15, L16, L17, L18, L19, L20, V1, V2, V3, V4, V5, V6, V7, V8, V9, V10, V11, V12, V13, V14, V15, V16)	----- ----- -----	

Description	Range	Default	Setting
BI 23 Operated <i>DC Binary Input 23 has operated</i>	Combination of (BO1, BO2, BO3, BO4, BO5, BO6, BO7, BO8, BO9, BO10, BO11, BO12, BO13, BO14, L1, L2, L3, L4, L5, L6, L7, L8, L9, L10, L11, L12, L13, L14, L15, L16, L17, L18, L19, L20, V1, V2, V3, V4, V5, V6, V7, V8, V9, V10, V11, V12, V13, V14, V15, V16)	----- ----- -----	
BI 24 Operated <i>DC Binary Input 24 has operated</i>	Combination of (BO1, BO2, BO3, BO4, BO5, BO6, BO7, BO8, BO9, BO10, BO11, BO12, BO13, BO14, L1, L2, L3, L4, L5, L6, L7, L8, L9, L10, L11, L12, L13, L14, L15, L16, L17, L18, L19, L20, V1, V2, V3, V4, V5, V6, V7, V8, V9, V10, V11, V12, V13, V14, V15, V16)	----- ----- -----	
BI 25 Operated <i>DC Binary Input 25 has operated</i>	Combination of (BO1, BO2, BO3, BO4, BO5, BO6, BO7, BO8, BO9, BO10, BO11, BO12, BO13, BO14, L1, L2, L3, L4, L5, L6, L7, L8, L9, L10, L11, L12, L13, L14, L15, L16, L17, L18, L19, L20, V1, V2, V3, V4, V5, V6, V7, V8, V9, V10, V11, V12, V13, V14, V15, V16)	----- ----- -----	
BI 26 Operated <i>DC Binary Input 26 has operated</i>	Combination of (BO1, BO2, BO3, BO4, BO5, BO6, BO7, BO8, BO9, BO10, BO11, BO12, BO13, BO14, L1, L2, L3, L4, L5, L6, L7, L8, L9, L10, L11, L12, L13, L14, L15, L16, L17, L18, L19, L20, V1, V2, V3, V4, V5, V6, V7, V8, V9, V10, V11, V12, V13, V14, V15, V16)	----- ----- -----	
BI 27 Operated <i>DC Binary Input 27 has operated</i>	Combination of (BO1, BO2, BO3, BO4, BO5, BO6, BO7, BO8, BO9, BO10, BO11, BO12, BO13, BO14, L1, L2, L3, L4, L5, L6, L7, L8, L9, L10, L11, L12, L13, L14, L15, L16, L17, L18, L19, L20, V1, V2, V3, V4, V5, V6, V7, V8, V9, V10, V11, V12, V13, V14, V15, V16)	----- ----- -----	
BI 28 Operated <i>DC Binary Input 28 has operated</i>	Combination of (BO1, BO2, BO3, BO4, BO5, BO6, BO7, BO8, BO9, BO10, BO11, BO12, BO13, BO14, L1, L2, L3, L4, L5, L6, L7, L8, L9, L10, L11, L12, L13, L14, L15, L16, L17, L18, L19, L20, V1, V2, V3, V4, V5, V6, V7, V8, V9, V10, V11, V12, V13, V14, V15, V16)	----- ----- -----	

Description	Range	Default	Setting
BI 29 Operated <i>DC Binary Input 29 has operated</i>	Combination of (BO1, BO2, BO3, BO4, BO5, BO6, BO7, BO8, BO9, BO10, BO11, BO12, BO13, BO14, L1, L2, L3, L4, L5, L6, L7, L8, L9, L10, L11, L12, L13, L14, L15, L16, L17, L18, L19, L20, V1, V2, V3, V4, V5, V6, V7, V8, V9, V10, V11, V12, V13, V14, V15, V16)	----- ----- -----	
BI 30 Operated <i>DC Binary Input 30 has operated</i>	Combination of (BO1, BO2, BO3, BO4, BO5, BO6, BO7, BO8, BO9, BO10, BO11, BO12, BO13, BO14, L1, L2, L3, L4, L5, L6, L7, L8, L9, L10, L11, L12, L13, L14, L15, L16, L17, L18, L19, L20, V1, V2, V3, V4, V5, V6, V7, V8, V9, V10, V11, V12, V13, V14, V15, V16)	----- ----- -----	
BI 31 Operated <i>DC Binary Input 31 has operated</i>	Combination of (BO1, BO2, BO3, BO4, BO5, BO6, BO7, BO8, BO9, BO10, BO11, BO12, BO13, BO14, L1, L2, L3, L4, L5, L6, L7, L8, L9, L10, L11, L12, L13, L14, L15, L16, L17, L18, L19, L20, V1, V2, V3, V4, V5, V6, V7, V8, V9, V10, V11, V12, V13, V14, V15, V16)	----- ----- -----	
BI 32 Operated <i>DC Binary Input 32 has operated</i>	Combination of (BO1, BO2, BO3, BO4, BO5, BO6, BO7, BO8, BO9, BO10, BO11, BO12, BO13, BO14, L1, L2, L3, L4, L5, L6, L7, L8, L9, L10, L11, L12, L13, L14, L15, L16, L17, L18, L19, L20, V1, V2, V3, V4, V5, V6, V7, V8, V9, V10, V11, V12, V13, V14, V15, V16)	----- ----- -----	
BI 33 Operated <i>DC Binary Input 33 has operated</i>	Combination of (BO1, BO2, BO3, BO4, BO5, BO6, BO7, BO8, BO9, BO10, BO11, BO12, BO13, BO14, L1, L2, L3, L4, L5, L6, L7, L8, L9, L10, L11, L12, L13, L14, L15, L16, L17, L18, L19, L20, V1, V2, V3, V4, V5, V6, V7, V8, V9, V10, V11, V12, V13, V14, V15, V16)	----- ----- -----	
E1 <i>Quick Logic equation 1 operated</i>	Combination of (BO1, BO2, BO3, BO4, BO5, BO6, BO7, BO8, BO9, BO10, BO11, BO12, BO13, BO14, L1, L2, L3, L4, L5, L6, L7, L8, L9, L10, L11, L12, L13, L14, L15, L16, L17, L18, L19, L20, V1, V2, V3, V4, V5, V6, V7, V8, V9, V10, V11, V12, V13, V14, V15, V16)	----- ----- -----	

Description	Range	Default	Setting
E2 <i>Quick Logic equation 2 operated</i>	Combination of (BO1, BO2, BO3, BO4, BO5, BO6, BO7, BO8, BO9, BO10, BO11, BO12, BO13, BO14, L1, L2, L3, L4, L5, L6, L7, L8, L9, L10, L11, L12, L13, L14, L15, L16, L17, L18, L19, L20, V1, V2, V3, V4, V5, V6, V7, V8, V9, V10, V11, V12, V13, V14, V15, V16)	----- ----- -----	
E3 <i>Quick Logic equation 3 operated</i>	Combination of (BO1, BO2, BO3, BO4, BO5, BO6, BO7, BO8, BO9, BO10, BO11, BO12, BO13, BO14, L1, L2, L3, L4, L5, L6, L7, L8, L9, L10, L11, L12, L13, L14, L15, L16, L17, L18, L19, L20, V1, V2, V3, V4, V5, V6, V7, V8, V9, V10, V11, V12, V13, V14, V15, V16)	----- ----- -----	
E4 <i>Quick Logic equation 4 operated</i>	Combination of (BO1, BO2, BO3, BO4, BO5, BO6, BO7, BO8, BO9, BO10, BO11, BO12, BO13, BO14, L1, L2, L3, L4, L5, L6, L7, L8, L9, L10, L11, L12, L13, L14, L15, L16, L17, L18, L19, L20, V1, V2, V3, V4, V5, V6, V7, V8, V9, V10, V11, V12, V13, V14, V15, V16)	----- ----- -----	
E5 <i>Quick Logic equation 5 operated</i>	Combination of (BO1, BO2, BO3, BO4, BO5, BO6, BO7, BO8, BO9, BO10, BO11, BO12, BO13, BO14, L1, L2, L3, L4, L5, L6, L7, L8, L9, L10, L11, L12, L13, L14, L15, L16, L17, L18, L19, L20, V1, V2, V3, V4, V5, V6, V7, V8, V9, V10, V11, V12, V13, V14, V15, V16)	----- ----- -----	
E6 <i>Quick Logic equation 6 operated</i>	Combination of (BO1, BO2, BO3, BO4, BO5, BO6, BO7, BO8, BO9, BO10, BO11, BO12, BO13, BO14, L1, L2, L3, L4, L5, L6, L7, L8, L9, L10, L11, L12, L13, L14, L15, L16, L17, L18, L19, L20, V1, V2, V3, V4, V5, V6, V7, V8, V9, V10, V11, V12, V13, V14, V15, V16)	----- ----- -----	
E7 <i>Quick Logic equation 7 operated</i>	Combination of (BO1, BO2, BO3, BO4, BO5, BO6, BO7, BO8, BO9, BO10, BO11, BO12, BO13, BO14, L1, L2, L3, L4, L5, L6, L7, L8, L9, L10, L11, L12, L13, L14, L15, L16, L17, L18, L19, L20, V1, V2, V3, V4, V5, V6, V7, V8, V9, V10, V11, V12, V13, V14, V15, V16)	----- ----- -----	

Description	Range	Default	Setting
E8 <i>Quick Logic equation 8 operated</i>	Combination of (BO1, BO2, BO3, BO4, BO5, BO6, BO7, BO8, BO9, BO10, BO11, BO12, BO13, BO14, L1, L2, L3, L4, L5, L6, L7, L8, L9, L10, L11, L12, L13, L14, L15, L16, L17, L18, L19, L20, V1, V2, V3, V4, V5, V6, V7, V8, V9, V10, V11, V12, V13, V14, V15, V16)	----- ----- -----	
E9 <i>Quick Logic equation 9 operated</i>	Combination of (BO1, BO2, BO3, BO4, BO5, BO6, BO7, BO8, BO9, BO10, BO11, BO12, BO13, BO14, L1, L2, L3, L4, L5, L6, L7, L8, L9, L10, L11, L12, L13, L14, L15, L16, L17, L18, L19, L20, V1, V2, V3, V4, V5, V6, V7, V8, V9, V10, V11, V12, V13, V14, V15, V16)	----- ----- -----	
E10 <i>Quick Logic equation 10 operated</i>	Combination of (BO1, BO2, BO3, BO4, BO5, BO6, BO7, BO8, BO9, BO10, BO11, BO12, BO13, BO14, L1, L2, L3, L4, L5, L6, L7, L8, L9, L10, L11, L12, L13, L14, L15, L16, L17, L18, L19, L20, V1, V2, V3, V4, V5, V6, V7, V8, V9, V10, V11, V12, V13, V14, V15, V16)	----- ----- -----	
E11 <i>Quick Logic equation 11 operated</i>	Combination of (BO1, BO2, BO3, BO4, BO5, BO6, BO7, BO8, BO9, BO10, BO11, BO12, BO13, BO14, L1, L2, L3, L4, L5, L6, L7, L8, L9, L10, L11, L12, L13, L14, L15, L16, L17, L18, L19, L20, V1, V2, V3, V4, V5, V6, V7, V8, V9, V10, V11, V12, V13, V14, V15, V16)	----- ----- -----	
E12 <i>Quick Logic equation 12 operated</i>	Combination of (BO1, BO2, BO3, BO4, BO5, BO6, BO7, BO8, BO9, BO10, BO11, BO12, BO13, BO14, L1, L2, L3, L4, L5, L6, L7, L8, L9, L10, L11, L12, L13, L14, L15, L16, L17, L18, L19, L20, V1, V2, V3, V4, V5, V6, V7, V8, V9, V10, V11, V12, V13, V14, V15, V16)	----- ----- -----	
E13 <i>Quick Logic equation 13 operated</i>	Combination of (BO1, BO2, BO3, BO4, BO5, BO6, BO7, BO8, BO9, BO10, BO11, BO12, BO13, BO14, L1, L2, L3, L4, L5, L6, L7, L8, L9, L10, L11, L12, L13, L14, L15, L16, L17, L18, L19, L20, V1, V2, V3, V4, V5, V6, V7, V8, V9, V10, V11, V12, V13, V14, V15, V16)	----- ----- -----	

Description	Range	Default	Setting
E14 <i>Quick Logic equation 14 operated</i>	Combination of (BO1, BO2, BO3, BO4, BO5, BO6, BO7, BO8, BO9, BO10, BO11, BO12, BO13, BO14, L1, L2, L3, L4, L5, L6, L7, L8, L9, L10, L11, L12, L13, L14, L15, L16, L17, L18, L19, L20, V1, V2, V3, V4, V5, V6, V7, V8, V9, V10, V11, V12, V13, V14, V15, V16)	----- ----- -----	
E15 <i>Quick Logic equation 15 operated</i>	Combination of (BO1, BO2, BO3, BO4, BO5, BO6, BO7, BO8, BO9, BO10, BO11, BO12, BO13, BO14, L1, L2, L3, L4, L5, L6, L7, L8, L9, L10, L11, L12, L13, L14, L15, L16, L17, L18, L19, L20, V1, V2, V3, V4, V5, V6, V7, V8, V9, V10, V11, V12, V13, V14, V15, V16)	----- ----- -----	
E16 <i>Quick Logic equation 16 operated</i>	Combination of (BO1, BO2, BO3, BO4, BO5, BO6, BO7, BO8, BO9, BO10, BO11, BO12, BO13, BO14, L1, L2, L3, L4, L5, L6, L7, L8, L9, L10, L11, L12, L13, L14, L15, L16, L17, L18, L19, L20, V1, V2, V3, V4, V5, V6, V7, V8, V9, V10, V11, V12, V13, V14, V15, V16)	----- ----- -----	

3.9.2. Binary Output Config

Description	Range	Default	Setting
Trip Contacts <i>The Binary Outputs selected by this setting are classed as Trip contacts. (When any of these BOs operate the Trip LED is lit, CB Fail is started, if enabled, & a Fault Record is stored)</i>	Combination of (BO1, BO2, BO3, BO4, BO5, BO6, BO7, BO8, BO9, BO10, BO11, BO12, BO13, BO14)	-----	
Hand Reset Outputs <i>Relays selected, as Hand Reset will remain latched until manually reset from front panel or via communications link or by removing DC Supply. By default relays are Self Resetting and will reset when the driving signal is removed.</i>	Combination of (1, 2, 3, 4, 5, 6, 7, 8, 9, 10, 11, 12, 13, 14)	-----	
Min Operate Time 1 <i>Minimum operate time of output relay if set to self reset, if also set to be pulsed then this is the pulse width</i>	0, 0.01 ... 59, 60	0.1s	
Min Operate Time 2 <i>Minimum operate time of output relay 2 if set to self reset, if also set to be pulsed then this is the pulse width</i>	0, 0.01 ... 59, 60	0.1s	
Min Operate Time 3 <i>Minimum operate time of output relay 3 if set to self reset, if also set to be pulsed then this is the pulse width</i>	0, 0.01 ... 59, 60	0.1s	

Description	Range	Default	Setting
Min Operate Time 4 <i>Minimum operate time of output relay 4 if set to self reset, if also set to be pulsed then this is the pulse width</i>	0, 0.01 ... 59, 60	0.1s	
Min Operate Time 5 <i>Minimum operate time of output relay 5 if set to self reset, if also set to be pulsed then this is the pulse width</i>	0, 0.01 ... 59, 60	0.1s	
Min Operate Time 6 <i>Minimum operate time of output relay 6 if set to self reset, if also set to be pulsed then this is the pulse width</i>	0, 0.01 ... 59, 60	0.1s	
Min Operate Time 7 <i>Minimum operate time of output relay 7 if set to self reset, if also set to be pulsed then this is the pulse width</i>	0, 0.01 ... 59, 60	0.1s	
Min Operate Time 8 <i>Minimum operate time of output relay 8 if set to self reset, if also set to be pulsed then this is the pulse width</i>	0, 0.01 ... 59, 60	0.1s	
Min Operate Time 9 <i>Minimum operate time of output relay 9 if set to self reset, if also set to be pulsed then this is the pulse width</i>	0, 0.01 ... 59, 60	0.1s	
Min Operate Time 10 <i>Minimum operate time of output relay 10 if set to self reset, if also set to be pulsed then this is the pulse width</i>	0, 0.01 ... 59, 60	0.1s	
Min Operate Time 11 <i>Minimum operate time of output relay 11 if set to self reset, if also set to be pulsed then this is the pulse width</i>	0, 0.01 ... 59, 60	0.1s	
Min Operate Time 12 <i>Minimum operate time of output relay 12 if set to self reset, if also set to be pulsed then this is the pulse width</i>	0, 0.01 ... 59, 60	0.1s	
Min Operate Time 13 <i>Minimum operate time of output relay 13 if set to self reset, if also set to be pulsed then this is the pulse width</i>	0, 0.01 ... 59, 60	0.1s	
Min Operate Time 14 <i>Minimum operate time of output relay 14 if set to self reset, if also set to be pulsed then this is the pulse width</i>	0, 0.01 ... 59, 60	0.1s	
Pulsed Outputs <i>Selects which outputs are pulsed. The pulse width is set by the Min Operate Time setting for each output</i>	Combination of (1, 2, 3, 4, 5, 6, 7, 8, 9, 10, 11, 12, 13, 14)	-----	

3.9.3. LED Config

Description	Range	Default	Setting
--------------------	--------------	----------------	----------------

Description	Range	Default	Setting
Self Reset LEDs <i>LEDs selected, as Self Reset will automatically reset when the driving signal is removed. By default all LEDs are Hand Reset and must be manually reset either locally via the front fascia or remotely via communications.</i>	Combination of (1, 2, 3, 4, 5, 6, 7, 8, 9, 10, 11, 12, 13, 14, 15, 16, 17, 18, 19, 20)	9, 10, 11, 12, 13, 14, 15, 16, 17, 18, 19, 20	
Green LEDs <i>Selects which LEDs will be green when driven</i>	Combination of (1, 2, 3, 4, 5, 6, 7, 8, 9, 10, 11, 12, 13, 14, 15, 16, 17, 18, 19, 20)	----- --	
Red LEDs <i>Selects which LEDs will be red when driven</i>	Combination of (1, 2, 3, 4, 5, 6, 7, 8, 9, 10, 11, 12, 13, 14, 15, 16, 17, 18, 19, 20)	1, 2, 3, 4, 5, 6, 7, 8, 9, 10, 11, 12, 13, 14, 15, 16, 17, 18, 19, 20	

3.9.4. Pickup Config

Description	Range	Default	Setting
Gn P/F Pickups <i>When any of the selected pickups operate General Pickup is driven.</i>	Combination of (51-1, 51-2, 51-3, 51-4, 50-1, 50-2, 50-3, 50-4)	51-1, 51-2, 51-3, 51-4, 50-1, 50-2, 50-3, 50-4	
Gn E/F Pickups <i>As Above</i>	Combination of (51G-1, 51G-2, 51G-3, 51G-4, 50G-1, 50G-2, 50G-3, 50G-4)	51G-1, 51G-2, 51G-3, 51G-4, 50G-1, 50G-2, 50G-3, 50G-4	
Gn SEF/REF Pickups <i>As Above</i>	Combination of (51SEF-1, 51SEF-2, 51SEF-3, 51SEF-4, 50SEF-1, 50SEF-2, 50SEF-3, 50SEF-4, 64H)	51SEF-1, 51SEF-2, 51SEF-3, 51SEF-4, 50SEF-1, 50SEF-2, 50SEF-3, 50SEF-4, 64H	
Gn Voltage Pickups <i>As Above</i>	Combination of (27/59-1, 27/59-2, 27/59-3, 27/59-4, Vx 27/59, 47-1, 47-2, 59NIT, 59NDT)	27/59-1, 27/59-2, 27/59-3, 27/59-4, Vx 27/59, 47-1, 47-2, 59NIT, 59NDT	
Gn Freq Pickups <i>As Above</i>	Combination of (81-1, 81-2, 81-3, 81-4)	81-1, 81-2, 81-3, 81-4	
Gn Misc Pickups <i>As Above</i>	Combination of (46IT, 46DT, 37-1, 37-2)	46IT, 46DT, 37-1, 37-2	

3.10. Maintenance

3.10.1. CB Counters

Description	Range	Default	Setting
-------------	-------	---------	---------

Description	Range	Default	Setting
Gn CB Total Trip Count <i>Selects whether the CB Total Trip Count counter is enabled</i>	Disabled, Enabled	Disabled	
Gn CB Total Trip Count Target <i>Selects the number of CB trips allowed before CB Total Trip Count counter output operates</i>	0, 1 ... 9999, 10000	100	
Gn CB Total Trip Count Reset <i>Resets CB Total Trip Count counter</i>			
Gn CB Delta Trip Count <i>Selects whether the CB Delta Trip Count counter is enabled</i>	Disabled, Enabled	Disabled	
Gn CB Delta Trip Count Target <i>Selects the number of CB trips allowed before CB Delta Trip Count counter output operates</i>	0, 1 ... 9999, 10000	100	
Gn CB Delta Trip Count Reset <i>Resets CB Delta Trip Count counter</i>			
Gn CB Count To AR Block <i>Selects whether the CB Count To AR Block counter is enabled</i>	Disabled, Enabled	Disabled	
Gn CB Count To AR Block Target <i>Selects the number of CB trips allowed before CB Count To AR Block counter output operates. While count is above target the Autorecloser will only perform 1 x Delayed Shot and Lockout</i>	0, 1 ... 9999, 10000	100	
Gn CB Count To AR Block Reset <i>Resets CB Count To AR Block counter</i>			
Gn CB Freq Ops Count <i>Selects whether the CB Frequent Operations Counter is enabled</i>	Disabled, Enabled	Disabled	
Gn CB Freq Ops Count Target <i>Selects the number of CB trips allowed before CB Frequent Operations Counter output operates. While count is above target the Autorecloser will only perform 1 x Delayed Shot and Lockout</i>	0, 1 ... 9999, 10000	10	
Gn CB Freq Ops Count Reset <i>Resets CB Frequent Operations Counter</i>			
Gn CB LO Handle Ops <i>Selects whether the CB Lockout operations Counter is enabled</i>	Disabled, Enabled	Disabled	
Gn CB LO Handle Ops Target <i>Selects the number of CB Lockout handle operations allowed before CB LO Handle Ops Count counter output operates</i>	0, 1 ... 9999, 10000	100	
Gn CB LO Handle Ops Reset <i>Resets CB Lockout Handle Operations Counter.</i>			

3.10.2. I²T CB Wear

Description	Range	Default	Setting
-------------	-------	---------	---------

Description	Range	Default	Setting
Gn I ² t Counter <i>Selects whether the I²t CB Wear monitor is enabled</i>	Disabled, Enabled	Disabled	
Gn Alarm Limit <i>Sets limit before alarm is issued</i>	10, 11 ... 99000, 100000	10MA ² s	
Gn Separation Time <i>Sets the time for CB mechanism to start moving, time before contacts start to separate</i>	0, 0.001 ... 0.199, 0.2	0.02s	
Gn Clearance Time <i>Time for CB to clear fault</i>	0, 0.001 ... 0.199, 0.2	0.04s	
Reset I ² t Count <i>Reset the CB wear count</i>			

3.10.3. Output Matrix Test

3.11. Data Storage

3.11.1. Demand/Data Log

Description	Range	Default	Setting
Data Log Period <i>Selects period between stored samples</i>	5, 6, 7, 8, 9, 10, 15, 20, 25, 30, 35, 40, 45, 50, 55, 60	5min	
Clear Data Log <i>Clear the Data Log</i>			
Gn Demand Window <i>The time window over which the Min, Max and Mean values are calculated.</i>	1, 2 ... 23, 24	24hrs	
Gn Demand Window Type <i>Method used to calculate Demand values.</i>	Fixed, Peak, Rolling	Fixed	
Gn Demand Reset <i>Reset all Demand values</i>			

3.11.2. Waveform Storage

Description	Range	Default	Setting
Gn P/F Trig Storage <i>Select which elements trigger a waveform record</i>	Combination of (51-1, 51-2, 51-3, 51-4, 50-1, 50-2, 50-3, 50-4)	51-1, 51-2, 51-3, 51-4, 50-1, 50-2, 50-3, 50-4	
Gn E/F Trig Storage <i>As Above</i>	Combination of (51G-1, 51G-2, 51G-3, 51G-4, 50G-1, 50G-2, 50G-3, 50G-4)	51G-1, 51G-2, 51G-3, 51G-4, 50G-1, 50G-2, 50G-3, 50G-4	

Description	Range	Default	Setting
Gn SEF/REF Trig Storage <i>As Above</i>	Combination of (51SEF-1, 51SEF-2, 51SEF-3, 51SEF-4, 50SEF-1, 50SEF-2, 50SEF-3, 50SEF-4, 64H)	51SEF-1, 51SEF-2, 51SEF-3, 51SEF-4, 50SEF-1, 50SEF-2, 50SEF-3, 50SEF-4, 64H	
Gn Misc Current Storage <i>As Above</i>	Combination of (46IT, 46DT, 37-1, 37-2, 49 Trip, 49 Alarm)	-----	
Gn Voltage Trig Storage <i>As Above</i>	Combination of (27/59-1, 27/59-2, 27/59-3, 27/59-4, Vx 27/59, 47-1, 47-2, 59NIT, 59NDT)	-----	
Gn Freq Trig Storage <i>As Above</i>	Combination of (81-1, 81-2, 81-3, 81-4)	----	
Pre-trigger Storage <i>Select Percentage of waveform record stored before the fault is triggered</i>	10, 20, 30, 40, 50, 60, 70, 80, 90	20%	
Record Duration <i>Select waveform record duration</i>	10 Rec x 1 Sec, 5 Rec x 2 Sec, 2 Rec x 5 Sec, 1 Rec x 10 Sec	10 Rec x 1 Sec	
Trigger Waveform <i>Trigger waveform storage</i>			
Clear Waveforms <i>Clear all stored waveform records</i>			

3.11.3. Fault Storage

Description	Range	Default	Setting
Gn Max Fault Rec Time <i>Maximum time Fault record information will be stored and classed as same fault</i>	0, 1 ... 59900, 60000	2000ms	
Clear Faults <i>Clear all stored fault records</i>			

3.11.4. Event Storage

Description	Range	Default	Setting
Clear Events <i>Clear all stored event records</i>			

3.11.5. Energy Storage

Description	Range	Default	Setting
Gn Active Exp Energy Unit	1kWh, 10kWh, 100kWh, 1MWh, 10MWh, 100MWh	10kWh	
Gn Active Imp Energy Unit	1kWh, 10kWh, 100kWh, 1MWh, 10MWh, 100MWh	10kWh	
Gn Reactive Exp Energy Unit	1kVArh, 10kVArh, 100kVArh, 1MVArh, 10MVArh, 100MVArh	10kVArh	

Description	Range	Default	Setting
Gn Reactive Imp Energy Unit	1kVArh, 10kVArh, 100kVArh, 1MVAh, 10MVAh, 100MVAh	10kVArh	

3.12. Communications

Description	Range	Default	Setting
Station Address <i>IEC 60870-5-103 Station Address</i>	0, 1 ... 65533, 65534	0	
COM1-RS485 Protocol <i>Selects protocol to use for COM1-RS485</i>	OFF, IEC60870-5-103, MODBUS-RTU, DNP3, IEC60870-5-101	IEC60870-5-103	
COM1-RS485 Baud Rate <i>Sets the communications baud rate for COM1-RS485</i>	75, 110, 150, 300, 600, 1200, 2400, 4800, 9600, 19200, 38400	19200	
COM1-RS485 Parity <i>Selects whether parity information is used</i>	NONE, ODD, EVEN	EVEN	
COM1-RS485 Mode	Local, Remote, Local Or Remote	Remote	
COM3 Protocol <i>Selects protocol to use for COM3</i>	OFF, IEC60870-5-103, MODBUS-RTU, DNP3, IEC60870-5-101	IEC60870-5-103	
COM3 Baud Rate <i>Sets the communications baud rate for COM3</i>	75, 110, 150, 300, 600, 1200, 2400, 4800, 9600, 19200, 38400, 57600, 115200	19200	
COM3 Parity <i>Selects whether parity information is used</i>	NONE, ODD, EVEN	EVEN	
COM3 Line Idle <i>Selects the communications line idle sense</i>	LIGHT OFF, LIGHT ON	LIGHT OFF	
COM3 Data Echo <i>Enables echoing of data from RX port to TX port when operating relays in a Fibre Optic ring configuration</i>	OFF, ON	OFF	
COM3 Mode	Local, Remote, Local Or Remote	Remote	
COM4 Protocol <i>Selects protocol to use for COM4</i>	OFF, IEC60870-5-103, MODBUS-RTU, DNP3, IEC60870-5-101	OFF	
COM4 Baud Rate <i>Sets the communications baud rate for COM4</i>	75, 110, 150, 300, 600, 1200, 2400, 4800, 9600, 19200, 38400	19200	
COM4 Parity <i>Selects whether parity information is used</i>	NONE, ODD, EVEN	EVEN	
COM4 Line Idle <i>Selects the communications line idle sense</i>	LIGHT OFF, LIGHT ON	LIGHT OFF	
COM4 Data Echo <i>Enables echoing of data from RX port to TX port when operating relays in a Fibre Optic ring configuration</i>	OFF, ON	OFF	

Description	Range	Default	Setting
COM4 Mode	Local, Remote, Local Or Remote	Remote	
DNP3 Unsolicited Events <i>Allows unsolicited event support in the relay. When Enabled, unsolicited event transmission can be controlled by the Master. When Disabled, Master requests are ignored.</i>	Disabled, Enabled	Disabled	
DNP3 Destination Address <i>The address of the master to which unsolicited events will be sent.</i>	0, 1 ... 65533, 65534	0	
DNP3 Application Timeout	5, 6 ... 299, 300	10s	
I101 Link Mode	Balanced, Unbalanced	Unbalanced	
I101 Link Address	Not Present, 1 Octet , 2 Octets	1 Octet	
I101 Common Address of Asdu	1 Octet , 2 Octets	2 Octets	
I101 Cause of Trans. (COT)	1 Octet , 2 Octets	1 Octet	
I101 Info. Obj. Add. (IOA)	1 Octet , 2 Octets, 3 Octets	2 Octets	
I101 Asdu Address	0, 1 ... 65534, 65535	3	
I101 Cyclic Period	Off, 1 ... 3599, 3600	60s	
I101 Background Period	Off, 1 ... 1499, 1500	Off	

4. Relay Settings – Standard Plus LOV

4.1. System Config

Description	Range	Default	Setting
Language Setting <i>Selects the language in which the relay text will be displayed.</i>	English, USA-English	English	
Active Group <i>Selects which settings group is currently activated</i>			
System Frequency <i>Selects the Power System Frequency from 50 or 60 Hz</i>	50, 60	50Hz	
View/Edit Group <i>Selects which settings group is currently being displayed</i>			
Setting Dependencies <i>When enabled only active settings are displayed and all others hidden</i>	Disabled, Enabled	Enabled	
Favourite Meters Timer <i>Selects the time delay after which, if no key presses have been detected, the relay will begin to poll through any screens which have been selected as favourite instruments</i>	Off, 1, 2, 5, 10, 15, 30, 60	60min	
Backlight timer <i>Controls when the LCD backlight turns off</i>	Off, 1, 2, 5, 10, 15, 30, 60	5min	
Date <i>Sets the date, this setting can only be changed on the fascia or via Relay->Control->Set Time and Date</i>			
Time <i>Sets the time, this setting can only be changed on the fascia or via Relay->Control->Set Time and Date</i>			
Curr Set Display <i>Select whether the Pickup values are shown in terms of x Nominal, Primary or Secondary values on the Relay Fascia</i>	xNom, Primary, Secondary	xNom	
E/F Curr Set Display <i>As Above</i>	xNom, Primary, Secondary	xNom	
Export Power/Lag VAR <i>Selects the signs required for exporting power and lagging VARs</i>	+ve/+ve, +ve/-ve, -ve/+ve, -ve/-ve	+ve/+ve	
Select Grp Mode <i>Mode of operation of the group change from status input. Edge triggered ignores the status input once it has changed to the relevant group, where as with Level triggered the relay will only stay in the group it has changed to whilst the status input is being driven, after which it returns to the previous group.</i>	Edge triggered, Level triggered	Edge triggered	

Description	Range	Default	Setting
Clock Sync. From BI <i>Real time clock may be synchronised using a binary input (See Clock Sync. in Binary Input Menu)</i>	Disabled, Seconds, Minutes	Minutes	
Operating Mode <i>Selects the current operating mode of the relay. This can also be changed by a binary input mode selection.</i>	Out Of Service, Local, Remote, Local Or Remote	Local Or Remote	
Setting Password <i>Allows a 4 character alpha code to be entered as the password. Note that the display shows a password dependant encrypted code on the second line of the display</i>	(Password)	NONE	
Control Password <i>As Above</i>	(Password)	NONE	
Trip Alert <i>When Enabled the occurrence of a Trip will cause the relay to display the Trip Alert Screen, the only way to leave this screen is by acknowledging the trip through the TEST/RESET button on the relay fascia</i>	Disabled, Enabled	Enabled	
General Alarm Alert <i>When Enabled the occurrence of a General Alarm will cause the relay to display the General Alarm Screen, any relay fascia button being pressed will cancel this action and revert to the last screen being displayed prior to the alarm</i>	Disabled, Enabled	Enabled	
Relay Identifier <i>An alphanumeric string shown on the LCD normally used to identifier the circuit the relay is attached to or the relays purpose</i>	(16 Character String)	7SR224	
Circuit Identifier <i>An alphanumeric string shown on the LCD normally used to identify the circuit name or relay's purpose</i>	(16 Character String)		

4.2. CT/VT Config

Description	Range	Default	Setting
Phase Nom Voltage <i>Selects the nominal voltage setting Vn of the voltage input</i>	40, 40.1 ... 159.9, 160	63.5V	
Phase Voltage Trim Magnitude <i>Allows trimming of voltage magnitude, the setting value should be the voltage required to be added to get back to Phase Nom Voltage.</i>	0, 0.1 ... 19.9, 20	0V	
Phase Voltage Trim Angle <i>Allows trimming of voltage angle, the setting value is added to the current voltage angle</i>	-45, -44.9 ... 44.9, 45	0deg	
Phase Voltage Config <i>Required to allow for different types of physical VT connections.</i>	Van,Vbn,Vcn, Vab,Vbc,3V0, Va,Vb,Vc	Van,Vbn,Vcn	

Description	Range	Default	Setting
Phase VT Ratio Prim <i>VT ratio Primary value, used to scale primary voltage instruments</i>	(6 Character String)	132000	
Phase VT Ratio Sec <i>VT ratio Secondary value, used to scale primary voltage instruments</i>	40, 40.5 ... 159.5, 160	110	
Vx Nom Voltage <i>Selects the nominal voltage setting Vn of the voltage input</i>	40, 40.1 ... 159.9, 160	63.5V	
Vx Voltage Trim Magnitude <i>Allows trimming of voltage magnitude, the setting value should be the voltage required to be added to get back to Vx Nom Voltage.</i>	0, 0.1 ... 19.9, 20	0V	
Vx Voltage Trim Angle <i>Allows trimming of voltage angle, the setting value is added to the current voltage angle</i>	-45, -44.9 ... 44.9, 45	0deg	
Vx VT Ratio Prim <i>VT ratio Primary value, used to scale primary voltage instruments</i>	(6 Character String)	132000	
Vx VT Ratio Sec <i>VT ratio Secondary value, used to scale primary voltage instruments</i>	40, 40.5 ... 159.5, 160	110	
Phase Current Input <i>Selects whether 1 or 5 Amp terminals are being used for phase inputs</i>	1, 5	1A	
Phase CT Ratio <i>Phase CT ratio to scale primary current instruments</i>	1:0.2, 1:0.21 ... 5000:6.9, 5000:7	2000:1	
Earth Current Input <i>Selects whether 1 or 5 Amp terminals are being used for Measured Earth inputs</i>	1, 5	1A	
Earth CT Ratio <i>Measured Earth CT ratio to scale primary current instruments</i>	1:0.2, 1:0.21 ... 5000:6.9, 5000:7	2000:1	
I1, I2, I3 Connections <i>Allocates phase reference letters to the relay hardware current inputs</i>	ABC, ACB, BAC, BCA, CAB,CBA	ABC	
V1, V2, V3 Connections <i>Allocates phase reference letters to the relay hardware voltage inputs</i>	ABC, ACB, BAC, BCA, CAB,CBA	ABC	
Phase Rotation <i>Specifies the vectorial positive phase sequence order of the allocated phase references. This setting allows the relay to be applied on networks with abnormal phasor sequence.</i>	A,B,C A,C,B	A,B,C	

4.3. Function Config

Description	Range	Default	Setting
-------------	-------	---------	---------

Description	Range	Default	Setting
Gn Phase Overcurrent <i>When set to Disabled, no Phase Overcurrent elements will be functional and all associated settings will be hidden. (The Setting Dependencies setting being set to Disabled will make all settings visible but will not allow them to operate).</i>	Enabled, Disabled	Disabled	
Gn Voltage Cont O/C <i>When set to Disabled, no Voltage Cont O/C elements will be functional and all associated settings will be hidden. (The Setting Dependencies setting being set to Disabled will make all settings visible but will not allow them to operate).</i>	Enabled, Disabled	Disabled	
Gn Cold Load <i>When set to Disabled, no Cold Load elements will be functional and all associated settings will be hidden. (The Setting Dependencies setting being set to Disabled will make all settings visible but will not allow them to operate).</i>	Enabled, Disabled	Disabled	
Gn Measured E/F <i>When set to Disabled, no Measured E/F elements will be functional and all associated settings will be hidden. (The Setting Dependencies setting being set to Disabled will make all settings visible but will not allow them to operate).</i>	Enabled, Disabled	Disabled	
Gn Sensitive E/F <i>When set to Disabled, no Sensitive E/F elements will be functional and all associated settings will be hidden. (The Setting Dependencies setting being set to Disabled will make all settings visible but will not allow them to operate).</i>	Enabled, Disabled	Disabled	
Gn Restricted E/F <i>When set to Disabled, no Restricted E/F elements will be functional and all associated settings will be hidden. (The Setting Dependencies setting being set to Disabled will make all settings visible but will not allow them to operate).</i>	Enabled, Disabled	Disabled	
Gn NPS Overcurrent <i>When set to Disabled, no NPS Overcurrent elements will be functional and all associated settings will be hidden. (The Setting Dependencies setting being set to Disabled will make all settings visible but will not allow them to operate).</i>	Enabled, Disabled	Disabled	
Gn Under Current <i>When set to Disabled, no Under Current elements will be functional and all associated settings will be hidden. (The Setting Dependencies setting being set to Disabled will make all settings visible but will not allow them to operate).</i>	Enabled, Disabled	Disabled	

Description	Range	Default	Setting
Gn Thermal <i>When set to Disabled, no Thermal elements will be functional and all associated settings will be hidden. (The Setting Dependencies setting being set to Disabled will make all settings visible but will not allow them to operate).</i>	Enabled, Disabled	Disabled	
Gn Phase U/O Voltage <i>When set to Disabled, no Phase U/O Voltage elements will be functional and all associated settings will be hidden. (The Setting Dependencies setting being set to Disabled will make all settings visible but will not allow them to operate).</i>	Enabled, Disabled	Disabled	
Gn Vx U/O Voltage <i>When set to Disabled, no Vx U/O Voltage elements will be functional and all associated settings will be hidden. (The Setting Dependencies setting being set to Disabled will make all settings visible but will not allow them to operate).</i>	Enabled, Disabled	Disabled	
Gn NPS Overvoltage <i>When set to Disabled, no NPS Overvoltage elements will be functional and all associated settings will be hidden. (The Setting Dependencies setting being set to Disabled will make all settings visible but will not allow them to operate).</i>	Enabled, Disabled	Disabled	
Gn Neutral Overvoltage <i>When set to Disabled, no Neutral Overvoltage elements will be functional and all associated settings will be hidden. (The Setting Dependencies setting being set to Disabled will make all settings visible but will not allow them to operate).</i>	Enabled, Disabled	Disabled	
Gn U/O Frequency <i>When set to Disabled, no U/O Frequency elements will be functional and all associated settings will be hidden. (The Setting Dependencies setting being set to Disabled will make all settings visible but will not allow them to operate).</i>	Enabled, Disabled	Disabled	
Gn CB Fail <i>When set to Disabled, no CB Fail elements will be functional and all associated settings will be hidden. (The Setting Dependencies setting being set to Disabled will make all settings visible but will not allow them to operate).</i>	Enabled, Disabled	Disabled	
Gn VT Supervision <i>When set to Disabled, no VT Supervision elements will be functional and all associated settings will be hidden. (The Setting Dependencies setting being set to Disabled will make all settings visible but will not allow them to operate).</i>	Enabled, Disabled	Disabled	

Description	Range	Default	Setting
Gn CT Supervision <i>When set to Disabled, no CT Supervision elements will be functional and all associated settings will be hidden. (The Setting Dependencies setting being set to Disabled will make all settings visible but will not allow them to operate).</i>	Enabled, Disabled	Disabled	
Gn Broken Conductor <i>When set to Disabled, no Broken Conductor elements will be functional and all associated settings will be hidden. (The Setting Dependencies setting being set to Disabled will make all settings visible but will not allow them to operate).</i>	Enabled, Disabled	Disabled	
Gn Trip Cct Supervision <i>When set to Disabled, no Trip Cct Supervision elements will be functional and all associated settings will be hidden. (The Setting Dependencies setting being set to Disabled will make all settings visible but will not allow them to operate).</i>	Enabled, Disabled	Disabled	
Gn Inrush Detector <i>When set to Disabled, no Inrush Detector elements will be functional and all associated settings will be hidden. (The Setting Dependencies setting being set to Disabled will make all settings visible but will not allow them to operate).</i>	Enabled, Disabled	Disabled	
Gn CB Counters <i>When set to Disabled, no Gn CB Counter elements will be functional and all associated settings will be hidden. (The Setting Dependencies setting being set to Disabled will make all settings visible but will not allow them to operate).</i>	Enabled, Disabled	Disabled	
Gn I ² t CB Wear <i>When set to Disabled, no Gn I²t CB Wear elements will be functional and all associated settings will be hidden. (The Setting Dependencies setting being set to Disabled will make all settings visible but will not allow them to operate).</i>	Enabled, Disabled	Disabled	
Gn Battery Test <i>When set to Disabled, no Battery Test elements will be functional and all associated settings will be hidden. (The Setting Dependencies setting being set to Disabled will make all settings visible but will not allow them to operate).</i>	Enabled, Disabled	Disabled	
Gn Capacitor Test <i>When set to Disabled, no Capacitor Test elements will be functional and all associated settings will be hidden. (The Setting Dependencies setting being set to Disabled will make all settings visible but will not allow them to operate).</i>	Enabled, Disabled	Disabled	

Description	Range	Default	Setting
Gn LOV Automation <i>When set to Disabled, no LOV Automation elements will be functional and all associated settings will be hidden. (The Setting Dependencies setting being set to Disabled will make all settings visible but will not allow them to operate).</i>	Enabled, Disabled	Disabled	
Gn 27Sag & 59Swell <i>When set to Disabled, no 27Sag & 59Swell elements will be functional and all associated settings will be hidden. (The Setting Dependencies setting being set to Disabled will make all settings visible but will not allow them to operate).</i>	Enabled, Disabled	Disabled	

4.4. Current Prot'n

4.4.1. Phase Overcurrent

Description	Range	Default	Setting
Gn 67 Char Angle <i>Maximum torque angle for phase overcurrent elements</i>	-95, -94 ... 94, 95	45deg	
Gn 67 Minimum Voltage <i>Selects the directional elements minimum voltage, below which the element will be inhibited</i>	1, 1.5 ... 19.5, 20	1V	
Gn 67 2-out-of-3 Logic <i>Selects whether 2 out of 3 voting logic is enabled for phase overcurrent elements</i>	Enabled, Disabled	Disabled	
Gn 51/50 Measurement <i>Selects whether the RMS value used by the 51 & 50 elements is True RMS or only calculated at fundamental frequency</i>	RMS, Fundamental	RMS	

4.4.1.1. 51-1

Description	Range	Default	Setting
Gn 51-1 Element <i>Selects whether the 51-1 IDMTL Overcurrent element is enabled</i>	Disabled, Enabled	Disabled	
Gn 51-1 Dir. Control <i>Selects whether 51-1 element is non-directional, forward or reverse</i>	Non-Dir, Forward, Reverse	Non-Dir	
Gn 51-1 Setting <i>Pickup level</i>	0.05, 0.06 ... 2.49, 2.5	1xIn	
Gn 51-1 Char <i>Selects characteristic curve to be IEC or ANSI IDMTL or DTL</i>	DTL, IEC-NI ... 201, 202	IEC-NI	
Gn 51-1 Time Mult (IEC/ANSI) <i>Time multiplier (applicable to IEC and ANSI curves but not DTL selection)</i>	0.025, 0.05 ... 1.575, 1.6	1	

Description	Range	Default	Setting
Gn 51-1 Delay (DTL) <i>Delay (applicable only when DTL is selected for characteristic)</i>	0, 0.01 ... 19.99, 20	5s	
Gn 51-1 Min Operate Time <i>Minimum operate time of element.</i>	0, 0.01 ... 19.99, 20	0s	
Gn 51-1 Follower DTL <i>Additional definite time added after characteristic time</i>	0, 0.01 ... 19.99, 20	0s	
Gn 51-1 Reset <i>Selects between an ANSI decaying reset characteristic or a definite time reset</i>	(ANSI) Decaying, 0 ... 59, 60	0s	
Gn 51-1 VTS Action <i>Selects whether 51-1 element is blocked or made non-directional when VTS operates</i>	Off, Inhibit, Non-Dir	Off	
Gn 51-1 Inrush Action <i>Selects if the 51-1 element is blocked from operating when 2nd Harmonic Inrush Detector operates</i>	Off, Inhibit	Off	

4.4.1.2. 51-2

Description	Range	Default	Setting
Gn 51-2 Element <i>Selects whether the 51-2 IDMTL Overcurrent element is enabled</i>	Disabled, Enabled	Disabled	
Gn 51-2 Dir. Control <i>Selects whether 51-2 element is non-directional, forward or reverse</i>	Non-Dir, Forward, Reverse	Non-Dir	
Gn 51-2 Setting <i>Pickup level</i>	0.05, 0.06 ... 2.49, 2.5	1xIn	
Gn 51-2 Char <i>Selects characteristic curve to be IEC or ANSI IDMTL or DTL</i>	DTL, IEC-NI ... 201, 202	IEC-NI	
Gn 51-2 Time Mult (IEC/ANSI) <i>Time multiplier (applicable to IEC and ANSI curves but not DTL selection)</i>	0.025, 0.05 ... 1.575, 1.6	1	
Gn 51-2 Delay (DTL) <i>Delay (applicable only when DTL is selected for characteristic)</i>	0, 0.01 ... 19.99, 20	5s	
Gn 51-2 Min Operate Time <i>Minimum operate time of element.</i>	0, 0.01 ... 19.99, 20	0s	
Gn 51-2 Follower DTL <i>Additional definite time added after characteristic time</i>	0, 0.01 ... 19.99, 20	0s	
Gn 51-2 Reset <i>Selects between an ANSI decaying reset characteristic or a definite time reset</i>	(ANSI) Decaying, 0 ... 59, 60	0s	
Gn 51-2 VTS Action <i>Selects whether 51-2 element is blocked or made non-directional when VTS operates</i>	Off, Inhibit, Non-Dir	Off	
Gn 51-2 Inrush Action <i>Selects if the 51-2 element is blocked from operating when 2nd Harmonic Inrush Detector operates</i>	Off, Inhibit	Off	

4.4.1.3. 51-3

Description	Range	Default	Setting
Gn 51-3 Element <i>Selects whether the 51-3 IDMTL Overcurrent element is enabled</i>	Disabled, Enabled	Disabled	
Gn 51-3 Dir. Control <i>Selects whether 51-3 element is non-directional, forward or reverse</i>	Non-Dir, Forward, Reverse	Non-Dir	
Gn 51-3 Setting <i>Pickup level</i>	0.05, 0.06 ... 2.49, 2.5	1xIn	
Gn 51-3 Char <i>Selects characteristic curve to be IEC or ANSI IDMTL or DTL</i>	DTL, IEC-NI ... 201, 202	IEC-NI	
Gn 51-3 Time Mult (IEC/ANSI) <i>Time multiplier (applicable to IEC and ANSI curves but not DTL selection)</i>	0.025, 0.05 ... 1.575, 1.6	1	
Gn 51-3 Delay (DTL) <i>Delay (applicable only when DTL is selected for characteristic)</i>	0, 0.01 ... 19.99, 20	5s	
Gn 51-3 Min Operate Time <i>Minimum operate time of element.</i>	0, 0.01 ... 19.99, 20	0s	
Gn 51-3 Follower DTL <i>Additional definite time added after characteristic time</i>	0, 0.01 ... 19.99, 20	0s	
Gn 51-3 Reset <i>Selects between an ANSI decaying reset characteristic or a definite time reset</i>	(ANSI) Decaying, 0 ... 59, 60	0s	
Gn 51-3 VTS Action <i>Selects whether 51-3 element is blocked or made non-directional when VTS operates</i>	Off, Inhibit, Non-Dir	Off	
Gn 51-3 Inrush Action <i>Selects if the 51-3 element is blocked from operating when 2nd Harmonic Inrush Detector operates</i>	Off, Inhibit	Off	

4.4.1.4. 51-4

Description	Range	Default	Setting
Gn 51-4 Element <i>Selects whether the 51-4 IDMTL Overcurrent element is enabled</i>	Disabled, Enabled	Disabled	
Gn 51-4 Dir. Control <i>Selects whether 51-4 element is non-directional, forward or reverse</i>	Non-Dir, Forward, Reverse	Non-Dir	
Gn 51-4 Setting <i>Pickup level</i>	0.05, 0.06 ... 2.49, 2.5	1xIn	
Gn 51-4 Char <i>Selects characteristic curve to be IEC or ANSI IDMTL or DTL</i>	DTL, IEC-NI ... 201, 202	IEC-NI	
Gn 51-4 Time Mult (IEC/ANSI) <i>Time multiplier (applicable to IEC and ANSI curves but not DTL selection)</i>	0.025, 0.05 ... 1.575, 1.6	1	
Gn 51-4 Delay (DTL) <i>Delay (applicable only when DTL is selected for characteristic)</i>	0, 0.01 ... 19.99, 20	5s	
Gn 51-4 Min Operate Time <i>Minimum operate time of element.</i>	0, 0.01 ... 19.99, 20	0s	
Gn 51-4 Follower DTL <i>Additional definite time added after characteristic time</i>	0, 0.01 ... 19.99, 20	0s	
Gn 51-4 Reset <i>Selects between an ANSI decaying reset characteristic or a definite time reset</i>	(ANSI) Decaying, 0 ... 59, 60	0s	
Gn 51-4 VTS Action <i>Selects whether 51-4 element is blocked or made non-directional when VTS operates</i>	Off, Inhibit, Non-Dir	Off	
Gn 51-4 Inrush Action <i>Selects if the 51-4 element is blocked from operating when 2nd Harmonic Inrush Detector operates</i>	Off, Inhibit	Off	

4.4.1.5. 50-1

Description	Range	Default	Setting
Gn 50-1 Element <i>Selects whether the INST/ DTL Overcurrent element is enabled</i>	Disabled, Enabled	Disabled	
Gn 50-1 Dir. Control <i>Selects whether 50-1 element is non-directional, forward or reverse</i>	Non-Dir, Forward, Reverse	Non-Dir	
Gn 50-1 Setting <i>Pickup level</i>	0.05, 0.06 ... 49.5, 50	1xIn	
Gn 50-1 Delay <i>Sets operate delay time</i>	0, 0.01 ... 14300, 14400	0s	
Gn 50-1 VTS Action <i>Selects whether 50-1 element is blocked or made non-directional when VTS operates</i>	Off, Inhibit, Non-Dir	Off	
Gn 50-1 Inrush Action <i>Selects if the 50-1 element is blocked from operating when 2nd Harmonic Inrush Detector operates</i>	Off, Inhibit	Off	

4.4.1.6. 50-2

Description	Range	Default	Setting
Gn 50-2 Element <i>Selects whether the INST/ DTL Overcurrent element is enabled</i>	Disabled, Enabled	Disabled	
Gn 50-2 Dir. Control <i>Selects whether 50-2 element is non-directional, forward or reverse</i>	Non-Dir, Forward, Reverse	Non-Dir	
Gn 50-2 Setting <i>Pickup level</i>	0.05, 0.06 ... 49.5, 50	1xIn	
Gn 50-2 Delay <i>Sets operate delay time</i>	0, 0.01 ... 14300, 14400	0s	
Gn 50-2 VTS Action <i>Selects whether 50-2 element is blocked or made non-directional when VTS operates</i>	Off, Inhibit, Non-Dir	Off	
Gn 50-2 Inrush Action <i>Selects if the 50-2 element is blocked from operating when 2nd Harmonic Inrush Detector operates</i>	Off, Inhibit	Off	

4.4.1.7. 50-3

Description	Range	Default	Setting
Gn 50-3 Element <i>Selects whether the INST/ DTL Overcurrent element is enabled</i>	Disabled, Enabled	Disabled	
Gn 50-3 Dir. Control <i>Selects whether 50-3 element is non-directional, forward or reverse</i>	Non-Dir, Forward, Reverse	Non-Dir	
Gn 50-3 Setting <i>Pickup level</i>	0.05, 0.06 ... 49.5, 50	1xIn	
Gn 50-3 Delay <i>Sets operate delay time</i>	0, 0.01 ... 14300, 14400	0s	

Description	Range	Default	Setting
Gn 50-3 VTS Action <i>Selects whether 50-3 element is blocked or made non-directional when VTS operates</i>	Off, Inhibit, Non-Dir	Off	
Gn 50-3 Inrush Action <i>Selects if the 50-3 element is blocked from operating when 2nd Harmonic Inrush Detector operates</i>	Off, Inhibit	Off	

4.4.1.8. 50-4

Description	Range	Default	Setting
Gn 50-4 Element <i>Selects whether the INST/ DTL Overcurrent element is enabled</i>	Disabled, Enabled	Disabled	
Gn 50-4 Dir. Control <i>Selects whether 50-4 element is non-directional, forward or reverse</i>	Non-Dir, Forward, Reverse	Non-Dir	
Gn 50-4 Setting <i>Pickup level</i>	0.05, 0.06 ... 49.5, 50	1xIn	
Gn 50-4 Delay <i>Sets operate delay time</i>	0, 0.01 ... 14300, 14400	0s	
Gn 50-4 VTS Action <i>Selects whether 50-4 element is blocked or made non-directional when VTS operates</i>	Off, Inhibit, Non-Dir	Off	
Gn 50-4 Inrush Action <i>Selects if the 50-4 element is blocked from operating when 2nd Harmonic Inrush Detector operates</i>	Off, Inhibit	Off	

4.4.2. Voltage Cont O/C

Description	Range	Default	Setting
Gn 51V Element <i>Selects whether the Voltage Controlled Overcurrent element is enabled</i>	Disabled, Enabled	Disabled	
Gn 51V Setting <i>The voltage below which 51V operates</i>	5, 5.5 ... 199.5, 200	30V	
Gn 51V VTS Action <i>Selects whether or not the 51V element is blocked when VTS operates</i>	Off, Inhibit	Off	
Gn 51-1 Multiplier <i>Multiplier applied to the 51-1 element when VCO element has operated</i>	0.25, 0.3, 0.35, 0.4, 0.45, 0.5, 0.55, 0.6, 0.65, 0.7, 0.75, 0.8, 0.85, 0.9, 0.95, 1	0.5	
Gn 51-2 Multiplier <i>Multiplier applied to the 51-2 element when VCO element has operated</i>	0.25, 0.3, 0.35, 0.4, 0.45, 0.5, 0.55, 0.6, 0.65, 0.7, 0.75, 0.8, 0.85, 0.9, 0.95, 1	0.5	
Gn 51-3 Multiplier <i>Multiplier applied to the 51-3 element when VCO element has operated</i>	0.25, 0.3, 0.35, 0.4, 0.45, 0.5, 0.55, 0.6, 0.65, 0.7, 0.75, 0.8, 0.85, 0.9, 0.95, 1	0.5	
Gn 51-4 Multiplier <i>Multiplier applied to the 51-4 element when VCO element has operated</i>	0.25, 0.3, 0.35, 0.4, 0.45, 0.5, 0.55, 0.6, 0.65, 0.7, 0.75, 0.8, 0.85, 0.9, 0.95, 1	0.5	

4.4.3. Cold Load

Description	Range	Default	Setting
Cold Load <i>Selects whether the Cold Load element is enabled</i>	Disabled, Enabled	Disabled	
Pick-up Time <i>Cold Load operate time delay</i>	1, 1.1 ... 14100, 14400	600s	
Drop-off Time <i>Cold Load reset time delay</i>	1, 1.1 ... 14100, 14400	600s	
Reduced Current <i>Selects whether reduced current functionality is to be used</i>	Disabled, Enabled	Disabled	
Reduced Current Level <i>Selects current level below which Reduced Current Time is used for Cold Load reset delay</i>	0.05, 0.1 ... 2.45, 2.5	0.25xIn	
Reduced Current Time <i>Cold Load reset time delay used when reduced current active</i>	1, 1.1 ... 14100, 14400	600s	
Gn 51c-1 Setting <i>51-1 element parameter used when Cold Load operates</i>	0.05, 0.06 ... 2.49, 2.5	1xIn	
Gn 51c-1 Char <i>As Above</i>	DTL, IEC-NI ... 201, 202	IEC-NI	
Gn 51c-1 Time Mult (IEC/ANSI) <i>As Above</i>	0.025, 0.05 ... 1.575, 1.6	1	
Gn 51c-1 Delay (DTL) <i>As Above</i>	0, 0.01 ... 19.99, 20	5s	
Gn 51c-1 Min Operate Time <i>As Above</i>	0, 0.01 ... 19.99, 20	0s	
Gn 51c-1 Follower DTL <i>As Above</i>	0, 0.01 ... 19.99, 20	0s	
Gn 51c-1 Reset <i>As Above</i>	(ANSI) Decaying, 0 ... 59, 60	0s	
Gn 51c-2 Setting <i>51-2 element parameter used when Cold Load operates</i>	0.05, 0.06 ... 2.49, 2.5	1xIn	
Gn 51c-2 Char <i>As Above</i>	DTL, IEC-NI ... 201, 202	IEC-NI	
Gn 51c-2 Time Mult (IEC/ANSI) <i>As Above</i>	0.025, 0.05 ... 1.575, 1.6	1	
Gn 51c-2 Delay (DTL) <i>As Above</i>	0, 0.01 ... 19.99, 20	5s	
Gn 51c-2 Min Operate Time <i>As Above</i>	0, 0.01 ... 19.99, 20	0s	
Gn 51c-2 Follower DTL <i>As Above</i>	0, 0.01 ... 19.99, 20	0s	
Gn 51c-2 Reset <i>As Above</i>	(ANSI) Decaying, 0 ... 59, 60	0s	

Description	Range	Default	Setting
Gn 51c-3 Setting <i>51-3 element parameter used when Cold Load operates</i>	0.05, 0.06 ... 2.49, 2.5	1xln	
Gn 51c-3 Char <i>As Above</i>	DTL, IEC-NI ... 201, 202	IEC-NI	
Gn 51c-3 Time Mult (IEC/ANSI) <i>As Above</i>	0.025, 0.05 ... 1.575, 1.6	1	
Gn 51c-3 Delay (DTL) <i>As Above</i>	0, 0.01 ... 19.99, 20	5s	
Gn 51c-3 Min Operate Time <i>As Above</i>	0, 0.01 ... 19.99, 20	0s	
Gn 51c-3 Follower DTL <i>As Above</i>	0, 0.01 ... 19.99, 20	0s	
Gn 51c-3 Reset <i>As Above</i>	(ANSI) Decaying, 0 ... 59, 60	0s	
Gn 51c-4 Setting <i>51-4 element parameter used when Cold Load operates</i>	0.05, 0.06 ... 2.49, 2.5	1xln	
Gn 51c-4 Char <i>As Above</i>	DTL, IEC-NI ... 201, 202	IEC-NI	
Gn 51c-4 Time Mult (IEC/ANSI) <i>As Above</i>	0.025, 0.05 ... 1.575, 1.6	1	
Gn 51c-4 Delay (DTL) <i>As Above</i>	0, 0.01 ... 19.99, 20	5s	
Gn 51c-4 Min Operate Time <i>As Above</i>	0, 0.01 ... 19.99, 20	0s	
Gn 51c-4 Follower DTL <i>As Above</i>	0, 0.01 ... 19.99, 20	0s	
Gn 51c-4 Reset <i>As Above</i>	(ANSI) Decaying, 0 ... 59, 60	0s	

4.4.4. Measured E/F

Description	Range	Default	Setting
Gn 67G Char Angle <i>Maximum torque angle for measured earth fault elements</i>	-95, -94 ... 94, 95	-15deg	
Gn 67G Minimum Voltage <i>Selects the directional elements minimum voltage, below which the element will be inhibited</i>	0.33, 0.5, 1, 1.5, 2, 2.5, 3	0.33V	
Gn 51G/50G Measurement <i>Selects whether the RMS value used by the 51G & 50G elements is True RMS or only calculated at fundamental frequency. Calculated setting switches the current source from measured at I_4 to derived from sum of I_1-I_3</i>	RMS, Fundamental, Calculated	RMS	

4.4.4.1. 51G-1

Description	Range	Default	Setting
Gn 51G-1 Element <i>Selects whether the 51G-1 IDMTL measured Earth Fault element is enabled</i>	Disabled, Enabled	Disabled	
Gn 51G-1 Dir. Control <i>Selects whether 51G-1 element is non-directional, forward or reverse</i>	Non-Dir, Forward, Reverse	Non-Dir	
Gn 51G-1 Setting <i>Pickup level</i>	0.005, 0.006 ... 0.995, 1	0.5xIn	
Gn 51G-1 Char <i>Selects characteristic curve to be IEC or ANSI IDMTL or DTL</i>	DTL, IEC-NI ... 201, 202	IEC-NI	
Gn 51G-1 Time Mult (IEC/ANSI) <i>Time multiplier (applicable to IEC and ANSI curves but not DTL selection)</i>	0.025, 0.05 ... 1.575, 1.6	1	
Gn 51G-1 Delay (DTL) <i>Delay (applicable only when DTL is selected for characteristic)</i>	0, 0.01 ... 19.99, 20	5s	
Gn 51G-1 Min Operate Time <i>Minimum operate time of element.</i>	0, 0.01 ... 19.99, 20	0s	
Gn 51G-1 Follower DTL <i>Additional definite time added after characteristic time</i>	0, 0.01 ... 19.99, 20	0s	
Gn 51G-1 Reset <i>Selects between an ANSI decaying reset characteristic or DTL reset</i>	(ANSI) Decaying, 0 ... 59, 60	0s	
Gn 51G-1 VTS Action <i>Selects whether 51G-1 element is blocked or made non-directional when VTS operates</i>	Off, Inhibit, Non-Dir	Off	
Gn 51G-1 Inrush Action <i>Selects if the 51G-1 element is blocked from operating when 2nd Harmonic Inrush Detector operates</i>	Off, Inhibit	Off	

4.4.4.2. 51G-2

Description	Range	Default	Setting
Gn 51G-2 Element <i>Selects whether the 51G-2 IDMTL measured Earth Fault element is enabled</i>	Disabled, Enabled	Disabled	
Gn 51G-2 Dir. Control <i>Selects whether 51G-2 element is non-directional, forward or reverse</i>	Non-Dir, Forward, Reverse	Non-Dir	
Gn 51G-2 Setting <i>Pickup level</i>	0.005, 0.006 ... 0.995, 1	0.5xIn	
Gn 51G-2 Char <i>Selects characteristic curve to be IEC or ANSI IDMTL or DTL</i>	DTL, IEC-NI ... 201, 202	IEC-NI	
Gn 51G-2 Time Mult (IEC/ANSI) <i>Time multiplier (applicable to IEC and ANSI curves but not DTL selection)</i>	0.025, 0.05 ... 1.575, 1.6	1	

Description	Range	Default	Setting
Gn 51G-2 Delay (DTL) <i>Delay (applicable only when DTL is selected for characteristic)</i>	0, 0.01 ... 19.99, 20	5s	
Gn 51G-2 Min Operate Time <i>Minimum operate time of element.</i>	0, 0.01 ... 19.99, 20	0s	
Gn 51G-2 Follower DTL <i>Additional definite time added after characteristic time</i>	0, 0.01 ... 19.99, 20	0s	
Gn 51G-2 Reset <i>Selects between an ANSI decaying reset characteristic or DTL reset</i>	(ANSI) Decaying, 0 ... 59, 60	0s	
Gn 51G-2 VTS Action <i>Selects whether 51G-2 element is blocked or made non-directional when VTS operates</i>	Off, Inhibit, Non-Dir	Off	
Gn 51G-2 Inrush Action <i>Selects if the 51G-2 element is blocked from operating when 2nd Harmonic Inrush Detector operates</i>	Off, Inhibit	Off	

4.4.4.3. 51G-3

Description	Range	Default	Setting
Gn 51G-3 Element <i>Selects whether the 51G-3 IDMTL measured Earth Fault element is enabled</i>	Disabled, Enabled	Disabled	
Gn 51G-3 Dir. Control <i>Selects whether 51G-3 element is non-directional, forward or reverse</i>	Non-Dir, Forward, Reverse	Non-Dir	
Gn 51G-3 Setting <i>Pickup level</i>	0.005, 0.006 ... 0.995, 1	0.5xIn	
Gn 51G-3 Char <i>Selects characteristic curve to be IEC or ANSI IDMTL or DTL</i>	DTL, IEC-NI ... 201, 202	IEC-NI	
Gn 51G-3 Time Mult (IEC/ANSI) <i>Time multiplier (applicable to IEC and ANSI curves but not DTL selection)</i>	0.025, 0.05 ... 1.575, 1.6	1	
Gn 51G-3 Delay (DTL) <i>Delay (applicable only when DTL is selected for characteristic)</i>	0, 0.01 ... 19.99, 20	5s	
Gn 51G-3 Min Operate Time <i>Minimum operate time of element.</i>	0, 0.01 ... 19.99, 20	0s	
Gn 51G-3 Follower DTL <i>Additional definite time added after characteristic time</i>	0, 0.01 ... 19.99, 20	0s	
Gn 51G-3 Reset <i>Selects between an ANSI decaying reset characteristic or DTL reset</i>	(ANSI) Decaying, 0 ... 59, 60	0s	
Gn 51G-3 VTS Action <i>Selects whether 51G-3 element is blocked or made non-directional when VTS operates</i>	Off, Inhibit, Non-Dir	Off	
Gn 51G-3 Inrush Action <i>Selects if the 51G-3 element is blocked from operating when 2nd Harmonic Inrush Detector operates</i>	Off, Inhibit	Off	

4.4.4.4. 51G-4

Description	Range	Default	Setting
Gn 51G-4 Element <i>Selects whether the 51G-4 IDMTL measured Earth Fault element is enabled</i>	Disabled, Enabled	Disabled	
Gn 51G-4 Dir. Control <i>Selects whether 51G-4 element is non-directional, forward or reverse</i>	Non-Dir, Forward, Reverse	Non-Dir	
Gn 51G-4 Setting <i>Pickup level</i>	0.005, 0.006 ... 0.995, 1	0.5xIn	
Gn 51G-4 Char <i>Selects characteristic curve to be IEC or ANSI IDMTL or DTL</i>	DTL, IEC-NI ... 201, 202	IEC-NI	
Gn 51G-4 Time Mult (IEC/ANSI) <i>Time multiplier (applicable to IEC and ANSI curves but not DTL selection)</i>	0.025, 0.05 ... 1.575, 1.6	1	
Gn 51G-4 Delay (DTL) <i>Delay (applicable only when DTL is selected for characteristic)</i>	0, 0.01 ... 19.99, 20	5s	
Gn 51G-4 Min Operate Time <i>Minimum operate time of element.</i>	0, 0.01 ... 19.99, 20	0s	
Gn 51G-4 Follower DTL <i>Additional definite time added after characteristic time</i>	0, 0.01 ... 19.99, 20	0s	
Gn 51G-4 Reset <i>Selects between an ANSI decaying reset characteristic or DTL reset</i>	(ANSI) Decaying, 0 ... 59, 60	0s	
Gn 51G-4 VTS Action <i>Selects whether 51G-4 element is blocked or made non-directional when VTS operates</i>	Off, Inhibit, Non-Dir	Off	
Gn 51G-4 Inrush Action <i>Selects if the 51G-4 element is blocked from operating when 2nd Harmonic Inrush Detector operates</i>	Off, Inhibit	Off	

4.4.4.5. 50G-1

Description	Range	Default	Setting
Gn 50G-1 Element <i>Selects whether the DTL measured Earth fault element is enabled</i>	Disabled, Enabled	Disabled	
Gn 50G-1 Dir. Control <i>Selects whether 50G-1 element is non-directional, forward or reverse</i>	Non-Dir, Forward, Reverse	Non-Dir	
Gn 50G-1 Setting <i>Pickup level</i>	0.005, 0.006 ... 24.95, 25	0.5xIn	
Gn 50G-1 Delay <i>Sets operate delay time</i>	0, 0.01 ... 14300, 14400	0s	
Gn 50G-1 VTS Action <i>Selects whether 50G-1 element is blocked or made non-directional when VTS operates</i>	Off, Inhibit, Non-Dir	Off	
Gn 50G-1 Inrush Action <i>Selects if the 50G-1 element is blocked from operating when 2nd Harmonic Inrush Detector operates</i>	Off, Inhibit	Off	

4.4.4.6. 50G-2

Description	Range	Default	Setting
Gn 50G-2 Element <i>Selects whether the DTL measured Earth fault element is enabled</i>	Disabled, Enabled	Disabled	
Gn 50G-2 Dir. Control <i>Selects whether 50G-2 element is non-directional, forward or reverse</i>	Non-Dir, Forward, Reverse	Non-Dir	
Gn 50G-2 Setting <i>Pickup level</i>	0.005, 0.006 ... 24.95, 25	0.5xIn	
Gn 50G-2 Delay <i>Sets operate delay time</i>	0, 0.01 ... 14300, 14400	0s	
Gn 50G-2 VTS Action <i>Selects whether 50G-2 element is blocked or made non-directional when VTS operates</i>	Off, Inhibit, Non-Dir	Off	
Gn 50G-2 Inrush Action <i>Selects if the 50G-2 element is blocked from operating when 2nd Harmonic Inrush Detector operates</i>	Off, Inhibit	Off	

4.4.4.7. 50G-3

Description	Range	Default	Setting
Gn 50G-3 Element <i>Selects whether the DTL measured Earth fault element is enabled</i>	Disabled, Enabled	Disabled	
Gn 50G-3 Dir. Control <i>Selects whether 50G-3 element is non-directional, forward or reverse</i>	Non-Dir, Forward, Reverse	Non-Dir	
Gn 50G-3 Setting <i>Pickup level</i>	0.005, 0.006 ... 24.95, 25	0.5xIn	
Gn 50G-3 Delay <i>Sets operate delay time</i>	0, 0.01 ... 14300, 14400	0s	

Description	Range	Default	Setting
Gn 50G-3 VTS Action <i>Selects whether 50G-3 element is blocked or made non-directional when VTS operates</i>	Off, Inhibit, Non-Dir	Off	
Gn 50G-3 Inrush Action <i>Selects if the 50G-3 element is blocked from operating when 2nd Harmonic Inrush Detector operates</i>	Off, Inhibit	Off	

4.4.4.8. 50G-4

Description	Range	Default	Setting
Gn 50G-4 Element <i>Selects whether the DTL measured Earth fault element is enabled</i>	Disabled, Enabled	Disabled	
Gn 50G-4 Dir. Control <i>Selects whether 50G-4 element is non-directional, forward or reverse</i>	Non-Dir, Forward, Reverse	Non-Dir	
Gn 50G-4 Setting <i>Pickup level</i>	0.005, 0.006 ... 24.95, 25	0.5xIn	
Gn 50G-4 Delay <i>Sets operate delay time</i>	0, 0.01 ... 14300, 14400	0s	
Gn 50G-4 VTS Action <i>Selects whether 50G-4 element is blocked or made non-directional when VTS operates</i>	Off, Inhibit, Non-Dir	Off	
Gn 50G-4 Inrush Action <i>Selects if the 50G-4 element is blocked from operating when 2nd Harmonic Inrush Detector operates</i>	Off, Inhibit	Off	

4.4.5. Sensitive E/F

Description	Range	Default	Setting
Gn 67SEF Char Angle <i>Maximum torque angle for sensitive earth fault elements</i>	-95, -94 ... 94, 95	-15deg	
Gn 67SEF Minimum Voltage <i>Selects the directional elements minimum voltage, below which the element will be inhibited</i>	0.33, 0.5 ... 66.5, 67	0.33V	
Gn 67SEF Compensated Network <i>When Enabled the directional elements boundaries are widened to +- 87.5 Degs</i>	Disabled, Enabled	Disabled	

4.4.5.1. 51SEF-1

Description	Range	Default	Setting
Gn 51SEF-1 Element <i>Selects whether the 51SEF-1 IDMTL Sensitive Earth Fault element is enabled</i>	Disabled, Enabled	Disabled	
Gn 51SEF-1 Dir. Control <i>Selects whether 51SEF-1 element is non-directional, forward or reverse</i>	Non-Dir, Forward, Reverse	Non-Dir	
Gn 51SEF-1 Setting <i>Pickup level</i>	0.005, 0.006 ... 0.995, 1	0.2xIn	

Description	Range	Default	Setting
Gn 51SEF-1 Char <i>Selects characteristic curve to be IEC or ANSI IDMTL or DTL</i>	DTL, IEC-NI ... 201, 202	IEC-NI	
Gn 51SEF-1 Time Mult (IEC/ANSI) <i>Time multiplier (applicable to IEC and ANSI curves but not DTL selection)</i>	0.025, 0.05 ... 1.575, 1.6	1	
Gn 51SEF-1 Delay (DTL) <i>Delay (applicable only when DTL is selected for characteristic)</i>	0, 0.01 ... 19.99, 20	5s	
Gn 51SEF-1 Min Operate Time <i>Minimum operate time of element.</i>	0, 0.01 ... 19.99, 20	0s	
Gn 51SEF-1 Follower DTL <i>Additional definite time added after characteristic time</i>	0, 0.01 ... 19.99, 20	0s	
Gn 51SEF-1 Reset <i>Selects between an ANSI decaying reset characteristic or DTL reset</i>	(ANSI) Decaying, 0 ... 59, 60	0s	
Gn 51SEF-1 VTS Action <i>Selects whether 51SEF-1 element is blocked or made non-directional when VTS operates</i>	Off, Inhibit, Non-Dir	Off	

4.4.5.2. 51SEF-2

Description	Range	Default	Setting
Gn 51SEF-2 Element <i>Selects whether the 51SEF-2 IDMTL derived Earth Fault element is enabled</i>	Disabled, Enabled	Disabled	
Gn 51SEF-2 Dir. Control <i>Selects whether 51SEF-2 element is non-directional, forward or reverse</i>	Non-Dir, Forward, Reverse	Non-Dir	
Gn 51SEF-2 Setting <i>Pickup level</i>	0.005, 0.006 ... 0.995, 1	0.2xIn	
Gn 51SEF-2 Char <i>Selects characteristic curve to be IEC or ANSI IDMTL or DTL</i>	DTL, IEC-NI ... 201, 202	IEC-NI	
Gn 51SEF-2 Time Mult (IEC/ANSI) <i>Time multiplier (applicable to IEC and ANSI curves but not DTL selection)</i>	0.025, 0.05 ... 1.575, 1.6	1	
Gn 51SEF-2 Delay (DTL) <i>Delay (applicable only when DTL is selected for characteristic)</i>	0, 0.01 ... 19.99, 20	5s	
Gn 51SEF-2 Min Operate Time <i>Minimum operate time of element.</i>	0, 0.01 ... 19.99, 20	0s	
Gn 51SEF-2 Follower DTL <i>Additional definite time added after characteristic time</i>	0, 0.01 ... 19.99, 20	0s	
Gn 51SEF-2 Reset <i>Selects between an ANSI decaying reset characteristic or DTL reset</i>	(ANSI) Decaying, 0 ... 59, 60	0s	
Gn 51SEF-2 VTS Action <i>Selects whether 51SEF-2 element is blocked or made non-directional when VTS operates</i>	Off, Inhibit, Non-Dir	Off	

4.4.5.3. 51SEF-3

Description	Range	Default	Setting
Gn 51SEF-3 Element <i>Selects whether the 51SEF-3 IDMTL derived Earth Fault element is enabled</i>	Disabled, Enabled	Disabled	
Gn 51SEF-3 Dir. Control <i>Selects whether 51SEF-3 element is non-directional, forward or reverse</i>	Non-Dir, Forward, Reverse	Non-Dir	
Gn 51SEF-3 Setting <i>Pickup level</i>	0.005, 0.006 ... 0.995, 1	0.2xIn	
Gn 51SEF-3 Char <i>Selects characteristic curve to be IEC or ANSI IDMTL or DTL</i>	DTL, IEC-NI ... 201, 202	IEC-NI	
Gn 51SEF-3 Time Mult (IEC/ANSI) <i>Time multiplier (applicable to IEC and ANSI curves but not DTL selection)</i>	0.025, 0.05 ... 1.575, 1.6	1	
Gn 51SEF-3 Delay (DTL) <i>Delay (applicable only when DTL is selected for characteristic)</i>	0, 0.01 ... 19.99, 20	5s	
Gn 51SEF-3 Min Operate Time <i>Minimum operate time of element.</i>	0, 0.01 ... 19.99, 20	0s	
Gn 51SEF-3 Follower DTL <i>Additional definite time added after characteristic time</i>	0, 0.01 ... 19.99, 20	0s	
Gn 51SEF-3 Reset <i>Selects between an ANSI decaying reset characteristic or a definite time reset</i>	(ANSI) Decaying, 0 ... 59, 60	0s	
Gn 51SEF-3 VTS Action <i>Selects whether 51SEF-3 element is blocked or made non-directional when VTS operates</i>	Off, Inhibit, Non-Dir	Off	

4.4.5.4. 51SEF-4

Description	Range	Default	Setting
Gn 51SEF-4 Element <i>Selects whether the 51SEF-4 IDMTL derived Earth Fault element is enabled</i>	Disabled, Enabled	Disabled	
Gn 51SEF-4 Dir. Control <i>Selects whether 51SEF-4 element is non-directional, forward or reverse</i>	Non-Dir, Forward, Reverse	Non-Dir	
Gn 51SEF-4 Setting <i>Pickup level</i>	0.005, 0.006 ... 0.995, 1	0.2xIn	
Gn 51SEF-4 Char <i>Selects characteristic curve to be IEC or ANSI IDMTL or DTL</i>	DTL, IEC-NI ... 201, 202	IEC-NI	
Gn 51SEF-4 Time Mult (IEC/ANSI) <i>Time multiplier (applicable to IEC and ANSI curves but not DTL selection)</i>	0.025, 0.05 ... 1.575, 1.6	1	
Gn 51SEF-4 Delay (DTL) <i>Delay (applicable only when DTL is selected for characteristic)</i>	0, 0.01 ... 19.99, 20	5s	
Gn 51SEF-4 Min Operate Time <i>Minimum operate time of element.</i>	0, 0.01 ... 19.99, 20	0s	

Description	Range	Default	Setting
Gn 51SEF-4 Follower DTL <i>Additional definite time added after characteristic time</i>	0, 0.01 ... 19.99, 20	0s	
Gn 51SEF-4 Reset <i>Selects between an ANSI decaying reset characteristic or a definite time reset</i>	(ANSI) Decaying, 0 ... 59, 60	0s	
Gn 51SEF-4 VTS Action <i>Selects whether 51SEF-4 element is blocked or made non-directional when VTS operates</i>	Off, Inhibit, Non-Dir	Off	

4.4.5.5. 50SEF-1

Description	Range	Default	Setting
Gn 50SEF-1 Element <i>Selects whether the DTL measured Earth fault element is enabled</i>	Disabled, Enabled	Disabled	
Gn 50SEF-1 Dir. Control <i>Selects whether 50SEF-1 element is non-directional, forward or reverse</i>	Non-Dir, Forward, Reverse	Non-Dir	
Gn 50SEF-1 Setting <i>Pickup level</i>	0.005, 0.006 ... 4.995, 5	0.2xIn	
Gn 50SEF-1 Delay <i>Sets operate delay time</i>	0, 0.01 ... 14300, 14400	0s	
Gn 50SEF-1 VTS Action <i>Selects whether 50SEF-1 element is blocked or made non-directional when VTS operates</i>	Off, Inhibit, Non-Dir	Off	

4.4.5.6. 50SEF-2

Description	Range	Default	Setting
Gn 50SEF-2 Element <i>Selects whether the DTL measured Earth fault element is enabled</i>	Disabled, Enabled	Disabled	
Gn 50SEF-2 Dir. Control <i>Selects whether 50SEF-2 element is non-directional, forward or reverse</i>	Non-Dir, Forward, Reverse	Non-Dir	
Gn 50SEF-2 Setting <i>Pickup level</i>	0.005, 0.006 ... 4.995, 5	0.2xIn	
Gn 50SEF-2 Delay <i>Sets operate delay time</i>	0, 0.01 ... 14300, 14400	0s	
Gn 50SEF-2 VTS Action <i>Selects whether 50SEF-2 element is blocked or made non-directional when VTS operates</i>	Off, Inhibit, Non-Dir	Off	

4.4.5.7. 50SEF-3

Description	Range	Default	Setting
Gn 50SEF-3 Element <i>Selects whether the DTL measured Earth fault element is enabled</i>	Disabled, Enabled	Disabled	
Gn 50SEF-3 Dir. Control <i>Selects whether 50SEF-3 element is non-directional, forward or reverse</i>	Non-Dir, Forward, Reverse	Non-Dir	
Gn 50SEF-3 Setting <i>Pickup level</i>	0.005, 0.006 ... 4.995, 5	0.2xIn	

Description	Range	Default	Setting
Gn 50SEF-3 Delay <i>Sets operate delay time</i>	0, 0.01 ... 14300, 14400	0s	
Gn 50SEF-3 VTS Action <i>Selects whether 50SEF-3 element is blocked or made non-directional when VTS operates</i>	Off, Inhibit, Non-Dir	Off	

4.4.5.8. 50SEF-4

Description	Range	Default	Setting
Gn 50SEF-4 Element <i>Selects whether the DTL measured Earth fault element is enabled</i>	Disabled, Enabled	Disabled	
Gn 50SEF-4 Dir. Control <i>Selects whether 50SEF-4 element is non-directional, forward or reverse</i>	Non-Dir, Forward, Reverse	Non-Dir	
Gn 50SEF-4 Setting <i>Pickup level</i>	0.005, 0.006 ... 4.995, 5	0.2xIn	
Gn 50SEF-4 Delay <i>Sets operate delay time</i>	0, 0.01 ... 14300, 14400	0s	
Gn 50SEF-4 VTS Action <i>Selects whether 50SEF-4 element is blocked or made non-directional when VTS operates</i>	Off, Inhibit, Non-Dir	Off	

4.4.6. Restricted E/F

Description	Range	Default	Setting
Gn 64H Element <i>High impedance restricted earth fault current element</i>	Disabled, Enabled	Disabled	
Gn 64H Setting <i>Pickup level</i>	0.005, 0.006 ... 0.945, 0.95	0.2xIn	
Gn 64H Delay <i>Sets operate delay time</i>	0, 0.01 ... 14300, 14400	0s	

4.4.7. NPS Overcurrent

4.4.7.1. 46IT

Description	Range	Default	Setting
Gn 46IT Element <i>Selects whether the 46IT IDMTL/DTL negative phase sequence current element is enabled</i>	Disabled, Enabled	Disabled	
Gn 46IT Setting <i>Pickup level</i>	0.05, 0.06 ... 2.49, 2.5	0.25xIn	
Gn 46IT Char <i>Selects characteristic curve to be IEC or ANSI IDMTL or DTL</i>	DTL, IEC-NI, IEC-VI, IEC-EI, IEC-LTI, ANSI-MI, ANSI-VI, ANSI-EI	IEC-NI	
Gn 46IT Time Mult (IEC/ANSI) <i>Time multiplier (applicable to IEC and ANSI curves but not DTL selection)</i>	0.025, 0.05 ... 1.575, 1.6	1	
Gn 46IT Delay (DTL) <i>Delay (applicable only when DTL is selected for characteristic)</i>	0, 0.01 ... 19.99, 20	5s	
Gn 46IT Reset <i>Selects between an ANSI decaying reset characteristic or a definite time reset</i>	(ANSI) Decaying, 0 ... 59, 60	0s	

4.4.7.2. 46DT

Description	Range	Default	Setting
Gn 46DT Element <i>Selects whether the 46DT INST/DTL negative sequence current element is enabled</i>	Disabled, Enabled	Disabled	
Gn 46DT Setting <i>Pickup level</i>	0.05, 0.06 ... 3.99, 4	0.1xIn	
Gn 46DT Delay <i>Sets operate delay time</i>	0, 0.01 ... 14300, 14400	0.02s	

4.4.8. Under Current

4.4.8.1. 37-1

Description	Range	Default	Setting
Gn 37-1 Element <i>Phase under current element 37-1</i>	Disabled, Enabled	Disabled	
Gn 37-1 Setting <i>Pickup level</i>	0.05, 0.1 ... 4.95, 5	0.25xIn	
Gn 37-1 Delay <i>Sets operate delay time</i>	0, 0.01 ... 14300, 14400	0s	

4.4.8.2. 37-2

Description	Range	Default	Setting
Gn 37-2 Element <i>Phase under current element 37-2</i>	Disabled, Enabled	Disabled	
Gn 37-2 Setting <i>Pickup level</i>	0.05, 0.1 ... 4.95, 5	0.25xIn	

Description	Range	Default	Setting
Gn 37-2 Delay <i>Sets operate delay time</i>	0, 0.01 ... 14300, 14400	0s	

4.4.9. Thermal

Description	Range	Default	Setting
Gn 49 Thermal Overload <i>Selects whether the thermal overload protection element is enabled</i>	Disabled, Enabled	Disabled	
Gn 49 Overload Setting <i>Pickup level</i>	0.1, 0.11 ... 2.99, 3	1.05xIn	
Gn 49 Time Constant <i>Thermal time constant</i>	1, 1.5 ... 999.5, 1000	10m	
Gn 49 Capacity Alarm <i>Selects whether thermal capacity alarm enabled</i>	Disabled, 50 ... 99, 100	Disabled	
49 Reset Therm State <i>Control that allows thermal state to be manually reset</i>			

4.5. Voltage Prot'n

4.5.1. Phase U/O Voltage

Description	Range	Default	Setting
Gn Voltage Input Mode <i>Selects Ph-Ph or Ph-N voltages for U/V guard element & 27/59 elements operation.</i>	Ph-N, Ph-Ph	Ph-N	
Gn 27/59 U/V Guard Setting <i>Selects voltage level below which the guard element is applied.</i>	1, 1.5 ... 199.5, 200	5V	

4.5.1.1. 27/59-1

Description	Range	Default	Setting
Gn 27/59-1 Element <i>Selects whether the Under/Over voltage element stage 1 is enabled</i>	Disabled, Enabled	Disabled	
Gn 27/59-1 Operation <i>Selects between Undervoltage and Overvoltage pickup for this element</i>	Under, Over	Over	
Gn 27/59-1 Setting <i>Under or over voltage pickup level</i>	5, 5.5 ... 199.5, 200	80V	
Gn 27/59-1 Hysteresis <i>Sets the pickup to dropoff thresholds e.g. 3% on Overlevel picks up above pickup setting and drops off below 97% of setting, 3% on Underlevel picks up below setting and drops off above 103% of setting</i>	0, 0.1 ... 79.9, 80	3%	
Gn 27/59-1 Delay <i>Sets operate delay time</i>	0, 0.01 ... 14300, 14400	0.1s	

Description	Range	Default	Setting
Gn 27/59-1 U/V Guarded <i>Selects whether U/V Guard element can block the operation of this element</i>	No, Yes	No	
Gn 27/59-1 VTS Inhibit <i>Selects whether element is blocked or not when VTS operates</i>	No, Yes	No	
Gn 27/59-1 O/P Phases <i>Selects whether element operates for any phase picked up or only when all phases are picked up</i>	Any, All	Any	

4.5.1.2. 27/59-2

Description	Range	Default	Setting
Gn 27/59-2 Element <i>Selects whether the Under/Over voltage element stage 2 is enabled</i>	Disabled, Enabled	Disabled	
Gn 27/59-2 Operation <i>Selects between Undervoltage and Overvoltage pickup for this element</i>	Under, Over	Over	
Gn 27/59-2 Setting <i>Under or over voltage pickup level</i>	5, 5.5 ... 199.5, 200	80V	
Gn 27/59-2 Hysteresis <i>Sets the pickup to dropoff thresholds e.g. 3% on Overlevel picks up above pickup setting and drops off below 97% of setting, 3% on Underlevel picks up below setting and drops off above 103% of setting</i>	0, 0.1 ... 79.9, 80	3%	
Gn 27/59-2 Delay <i>Sets operate delay time</i>	0, 0.01 ... 14300, 14400	0.1s	
Gn 27/59-2 U/V Guarded <i>Selects whether U/V Guard element can block the operation of this element</i>	No, Yes	No	
Gn 27/59-2 VTS Inhibit <i>Selects whether element is blocked or not when VTS operates</i>	No, Yes	No	
Gn 27/59-2 O/P Phases <i>Selects whether element operates for any phase picked up or only when all phases are picked up</i>	Any, All	Any	

4.5.1.3. 27/59-3

Description	Range	Default	Setting
Gn 27/59-3 Element <i>Selects whether the Under/Over voltage element stage 3 is enabled</i>	Disabled, Enabled	Disabled	
Gn 27/59-3 Operation <i>Selects between Undervoltage and Overvoltage pickup for this element</i>	Under, Over	Under	
Gn 27/59-3 Setting <i>Under or over voltage pickup level</i>	5, 5.5 ... 199.5, 200	50V	

Description	Range	Default	Setting
Gn 27/59-3 Hysteresis <i>Sets the pickup to dropoff thresholds e.g. 3% on Overlevel picks up above pickup setting and drops off below 97% of setting, 3% on Underlevel picks up below setting and drops off above 103% of setting</i>	0, 0.1 ... 79.9, 80	3%	
Gn 27/59-3 Delay <i>Sets operate delay time</i>	0, 0.01 ... 14300, 14400	0.1s	
Gn 27/59-3 U/V Guarded <i>Selects whether U/V Guard element can block the operation of this element</i>	No, Yes	Yes	
Gn 27/59-3 VTS Inhibit <i>Selects whether element is blocked or not when VTS operates</i>	No, Yes	No	
Gn 27/59-3 O/P Phases <i>Selects whether element operates for any phase picked up or only when all phases are picked up</i>	Any, All	Any	

4.5.1.4. 27/59-4

Description	Range	Default	Setting
Gn 27/59-4 Element <i>Selects whether the Under/Over voltage element stage 4 is enabled</i>	Disabled, Enabled	Disabled	
Gn 27/59-4 Operation <i>Selects between Undervoltage and Overvoltage pickup for this element</i>	Under, Over	Under	
Gn 27/59-4 Setting <i>Under or over voltage pickup level</i>	5, 5.5 ... 199.5, 200	50V	
Gn 27/59-4 Hysteresis <i>Sets the pickup to dropoff thresholds e.g. 3% on Overlevel picks up above pickup setting and drops off below 97% of setting, 3% on Underlevel picks up below setting and drops off above 103% of setting</i>	0, 0.1 ... 79.9, 80	3%	
Gn 27/59-4 Delay <i>Sets operate delay time</i>	0, 0.01 ... 14300, 14400	0.1s	
Gn 27/59-4 U/V Guarded <i>Selects whether U/V Guard element can block the operation of this element</i>	No, Yes	Yes	
Gn 27/59-4 VTS Inhibit <i>Selects whether element is blocked or not when VTS operates</i>	No, Yes	No	
Gn 27/59-4 O/P Phases <i>Selects whether element operates for any phase picked up or only when all phases are picked up</i>	Any, All	Any	

4.5.2. Vx U/O Voltage

Description	Range	Default	Setting
Gn Vx 27/59 Element <i>Selects whether the Under/Over voltage element for Vx is enabled</i>	Disabled, Enabled	Disabled	

Description	Range	Default	Setting
Gn Vx 27/59 Operation <i>Selects between Undervoltage and Overvoltage pickup for this element</i>	Under, Over	Over	
Gn Vx 27/59 Setting <i>Under or over voltage pickup level</i>	5, 5.5 ... 199.5, 200	80V	
Gn Vx 27/59 Hysteresis <i>Sets the pickup to dropoff thresholds e.g. 3% on Overlevel picks up above pickup setting and drops off below 97% of setting, 3% on Underlevel picks up below setting and drops off above 103% of setting</i>	0, 0.1 ... 79.9, 80	3%	
Gn Vx 27/59 Delay <i>Sets operate delay time</i>	0, 0.01 ... 14300, 14400	0.1s	

4.5.3. NPS Overvoltage

4.5.3.1. 47-1

Description	Range	Default	Setting
Gn 47-1 Element <i>Selects whether the definite time NPS overvoltage element is enabled</i>	Disabled, Enabled	Disabled	
Gn 47-1 Setting <i>Pickup level</i>	1, 1.5 ... 89.5, 90	20V	
Gn 47-1 Hysteresis <i>Sets the pickup to drop-off thresholds e.g. 3% picks up at setting and drops off below 97% of setting</i>	0, 0.1 ... 79.9, 80	3%	
Gn 47-1 Delay <i>Sets operate delay time</i>	0, 0.01 ... 14300, 14400	1s	

4.5.3.2. 47-2

Description	Range	Default	Setting
Gn 47-2 Element <i>Selects whether the definite time NPS overvoltage element is enabled</i>	Disabled, Enabled	Disabled	
Gn 47-2 Setting <i>Pickup level</i>	1, 1.5 ... 89.5, 90	20V	
Gn 47-2 Hysteresis <i>Sets the pickup to drop-off thresholds e.g. 3% picks up at setting and drops off below 97% of setting</i>	0, 0.1 ... 79.9, 80	3%	
Gn 47-2 Delay <i>Sets operate delay time</i>	0, 0.01 ... 14300, 14400	0.5s	

4.5.4. Neutral Overvoltage

Description	Range	Default	Setting
Gn 59N Voltage Source <i>Selects voltage source between calculated 3V0 (Vn) or measured 3V0 through Vx input</i>	Vn, Vx	Vn	

4.5.4.1. 59NIT

Description	Range	Default	Setting
Gn 59NIT Element <i>Selects whether the inverse time neutral over voltage element is enabled</i>	Disabled, Enabled	Disabled	
Gn 59NIT Setting <i>Pickup level</i>	1, 1.5 ... 99.5, 100	5V	
Gn 59NIT Char <i>Selects characteristic curve to be IDMTL or DTL</i>	DTL, IDMTL	IDMTL	
Gn 59NIT Time Mult (IDMTL) <i>Time multiplier (applicable to IDMTL curve but not DTL selection)</i>	0.1, 0.2 ... 139.5, 140	1	
Gn 59NIT Delay (DTL) <i>Delay (applicable only when DTL is selected for characteristic)</i>	0, 0.01 ... 19.99, 20	5s	
Gn 59NIT Reset <i>Selects between an instantaneous reset characteristic or a definite time reset</i>	(ANSI) Decaying, 0 ... 59, 60	0s	

4.5.4.2. 59NDT

Description	Range	Default	Setting
Gn 59NDT Element <i>Selects whether the definite time neutral over voltage element is enabled</i>	Disabled, Enabled	Disabled	
Gn 59NDT Setting <i>Pickup level</i>	1, 1.5 ... 99.5, 100	5V	
Gn 59NDT Delay <i>Sets operate delay time</i>	0, 0.01 ... 14300, 14400	0.01s	

4.5.5. U/O Frequency

Description	Range	Default	Setting
Gn 81 U/V Guard Setting <i>Selects voltage level below which the guard element is applied.</i>	5, 5.5 ... 199.5, 200	5V	

4.5.5.1. 81-1

Description	Range	Default	Setting
Gn 81-1 Element <i>Selects whether the Under/Over frequency element stage 1 is enabled</i>	Disabled, Enabled	Disabled	
Gn 81-1 Operation <i>Selects between Underfrequency and Overfrequency pickup for this element</i>	Under, Over	Under	
Gn 81-1 Setting <i>Under or over frequency pickup level</i>	40, 40.01 ... 69.98, 69.99	49.5Hz	
Gn 81-1 Hysteresis <i>Sets the pickup to dropoff thresholds e.g. 3% on Overlevel picks up above pickup setting and drops off below 97% of setting, 3% on Underlevel picks up below setting and drops off above 103% of setting</i>	0, 0.1 ... 79.9, 80	0.1%	

Description	Range	Default	Setting
Gn 81-1 Delay <i>Sets operate delay time</i>	0, 0.01 ... 14300, 14400	1s	
Gn 81-1 U/V Guarded <i>Selects whether U/V Guard element can block the operation of this element</i>	No, Yes	Yes	

4.5.5.2. 81-2

Description	Range	Default	Setting
Gn 81-2 Element <i>Selects whether the Under/Over frequency element stage 2 is enabled</i>	Disabled, Enabled	Disabled	
Gn 81-2 Operation <i>Selects between Underfrequency and Overfrequency pickup for this element</i>	Under, Over	Under	
Gn 81-2 Setting <i>Under or over frequency pickup level</i>	40, 40.01 ... 69.98, 69.99	49Hz	
Gn 81-2 Hysteresis <i>Sets the pickup to dropoff thresholds e.g. 3% on Overlevel picks up above pickup setting and drops off below 97% of setting, 3% on Underlevel picks up below setting and drops off above 103% of setting</i>	0, 0.1 ... 79.9, 80	0.1%	
Gn 81-2 Delay <i>Sets operate delay time</i>	0, 0.01 ... 14300, 14400	0.8s	
Gn 81-2 U/V Guarded <i>Selects whether U/V Guard element can block the operation of this element</i>	No, Yes	Yes	

4.5.5.3. 81-3

Description	Range	Default	Setting
Gn 81-3 Element <i>Selects whether the Under/Over frequency element stage 3 is enabled</i>	Disabled, Enabled	Disabled	
Gn 81-3 Operation <i>Selects between Underfrequency and Overfrequency pickup for this element</i>	Under, Over	Under	
Gn 81-3 Setting <i>Under or over frequency pickup level</i>	40, 40.01 ... 69.98, 69.99	48Hz	
Gn 81-3 Hysteresis <i>Sets the pickup to dropoff thresholds e.g. 3% on Overlevel picks up above pickup setting and drops off below 97% of setting, 3% on Underlevel picks up below setting and drops off above 103% of setting</i>	0, 0.1 ... 79.9, 80	0.1%	
Gn 81-3 Delay <i>Sets operate delay time</i>	0, 0.01 ... 14300, 14400	0.6s	
Gn 81-3 U/V Guarded <i>Selects whether U/V Guard element can block the operation of this element</i>	No, Yes	Yes	

4.5.5.4. 81-4

Description	Range	Default	Setting
Gn 81-4 Element <i>Selects whether the Under/Over frequency element stage 4 is enabled</i>	Disabled, Enabled	Disabled	
Gn 81-4 Operation <i>Selects between Underfrequency and Overfrequency pickup for this element</i>	Under, Over	Under	
Gn 81-4 Setting <i>Under or over frequency pickup level</i>	40, 40.01 ... 69.98, 69.99	47.5Hz	
Gn 81-4 Hysteresis <i>Sets the pickup to dropoff thresholds e.g. 3% on Overlevel picks up above pickup setting and drops off below 97% of setting, 3% on Underlevel picks up below setting and drops off above 103% of setting</i>	0, 0.1 ... 79.9, 80	0.1%	
Gn 81-4 Delay <i>Sets operate delay time</i>	0, 0.01 ... 14300, 14400	0.4s	
Gn 81-4 U/V Guarded <i>Selects whether U/V Guard element can block the operation of this element</i>	No, Yes	Yes	

4.6. Supervision

4.6.1. CB Fail

Description	Range	Default	Setting
Gn 50BF Element <i>Selects whether the Circuit Breaker Fail element is enabled</i>	Disabled, Enabled	Disabled	
Gn 50BF Setting <i>Breaker Fail Current Pickup level. If the current falls below this level then the CB is deemed to have opened and the element is reset.</i>	0.05, 0.055 ... 1.995, 2	0.2xIn	
Gn 50BF-I4 Setting	0.005, 0.01 ... 1.995, 2	0.05xIn	
Gn 50BF-1 Delay <i>Delay before Circuit Breaker Fail stage 1 operates</i>	20, 25 ... 59995, 60000	60ms	
Gn 50BF-2 Delay <i>Delay before Circuit Breaker Fail stage 2 operates</i>	20, 25 ... 59995, 60000	120ms	

4.6.2. VT Supervision

Description	Range	Default	Setting
Gn 60VTS Element <i>Selects whether the VT supervision element is enabled</i>	Disabled, Enabled	Disabled	

Description	Range	Default	Setting
Gn 60VTS Component <i>Selects whether NPS or ZPS quantities are used by the VT supervision element</i>	NPS, ZPS	NPS	
Gn 60VTS V <i>Level above which there is a possible 1 or 2 phase VT fuse failure</i>	7, 8 ... 109, 110	7V	
Gn 60VTS I <i>Level above which a 1 or 2 phase fault condition is assumed so VTS inhibited</i>	0.05, 0.1, 0.15, 0.2, 0.25, 0.3, 0.35, 0.4, 0.45, 0.5, 0.55, 0.6, 0.65, 0.7, 0.75, 0.8, 0.85, 0.9, 0.95, 1	0.1xIn	
Gn 60VTS Vpps <i>Level below which there is a possible 3 phase VT fuse failure</i>	1, 2 ... 109, 110	15V	
Gn 60VTS Ipps Load <i>Level current must be above before 3 phase VTS will be issued</i>	0.05, 0.1, 0.15, 0.2, 0.25, 0.3, 0.35, 0.4, 0.45, 0.5, 0.55, 0.6, 0.65, 0.7, 0.75, 0.8, 0.85, 0.9, 0.95, 1	0.1xIn	
Gn 60VTS Ipps Fault <i>Level above which 3 phase fault is assumed so VTS inhibited</i>	0.05, 0.1 ... 19.95, 20	10xIn	
Gn 60VTS Delay <i>Sets operate delay time</i>	0.03, 0.04 ... 14300, 14400	10s	
Gn 60VTS-X Element <i>Selects whether the VT supervision element is enabled</i>	Disabled, Enabled	Disabled	
Gn 60VTS-X Component <i>Selects whether NPS or ZPS quantities are used by the VT supervision element</i>	NPS, ZPS	NPS	
Gn 60VTS-X V <i>Level above which there is a possible 1 or 2 phase VT fuse failure</i>	7, 8 ... 109, 110	7V	
Gn 60VTS-X I <i>Level above which a 1 or 2 phase fault condition is assumed so VTS inhibited</i>	0.05, 0.1, 0.15, 0.2, 0.25, 0.3, 0.35, 0.4, 0.45, 0.5, 0.55, 0.6, 0.65, 0.7, 0.75, 0.8, 0.85, 0.9, 0.95, 1	0.1xIn	
Gn 60VTS-X Vpps <i>Level below which there is a possible 3 phase VT fuse failure</i>	1, 2 ... 109, 110	15V	
Gn 60VTS-X Ipps Load <i>Level current must be above before 3 phase VTS will be issued</i>	0.05, 0.1, 0.15, 0.2, 0.25, 0.3, 0.35, 0.4, 0.45, 0.5, 0.55, 0.6, 0.65, 0.7, 0.75, 0.8, 0.85, 0.9, 0.95, 1	0.1xIn	
Gn 60VTS-X Ipps Fault <i>Level above which 3 phase fault is assumed so VTS inhibited</i>	0.05, 0.1 ... 19.95, 20	10xIn	
Gn 60VTS-X Delay <i>Sets operate delay time</i>	0.03, 0.04 ... 14300, 14400	10s	

4.6.3.

4.6.4. CT Supervision

Description	Range	Default	Setting
Gn 60CTS Element <i>Selects whether the CT supervision element is enabled (NPS current in the absence of NPS voltage)</i>	Disabled, Enabled	Disabled	
Gn 60CTS Inps <i>Arm if NPS Current (Inps) is above this level</i>	0.05, 0.1, 0.15, 0.2, 0.25, 0.3, 0.35, 0.4, 0.45, 0.5, 0.55, 0.6, 0.65, 0.7, 0.75, 0.8, 0.85, 0.9, 0.95, 1	0.1xIn	
Gn 60CTS Vnps <i>Inhibit if NPS Voltage (Vnps) is above this level</i>	7, 8 ... 109, 110	10V	
Gn 60CTS Delay <i>CTS Operate delay</i>	0.03, 0.04 ... 14300, 14400	10s	

4.6.5. Broken Conductor

Description	Range	Default	Setting
Gn 46BC Element <i>Selects whether the definite time broken conductor element is enabled</i>	Disabled, Enabled	Disabled	
Gn 46BC Setting <i>NPS Current to PPS Current ratio</i>	20, 21 ... 99, 100	20%	
Gn 46BC Delay <i>Sets operate delay time</i>	0.03, 0.04 ... 14300, 14400	20s	

4.6.6. Trip CCT Supervision

Description	Range	Default	Setting
Gn 74TCS-1 <i>Selects whether the trip circuit supervision element 74TCS-1 is enabled</i>	Disabled, Enabled	Disabled	
Gn 74TCS-1 Delay <i>Time delay before trip circuit supervision operates</i>	0, 0.02 ... 59.98, 60	0.4s	
Gn 74TCS-2 <i>Selects whether the trip circuit supervision element 74TCS-2 is enabled</i>	Disabled, Enabled	Disabled	
Gn 74TCS-2 Delay <i>Time delay before trip circuit supervision operates</i>	0, 0.02 ... 59.98, 60	0.4s	
Gn 74TCS-3 <i>Selects whether the trip circuit supervision element 74TCS-3 is enabled</i>	Disabled, Enabled	Disabled	
Gn 74TCS-3 Delay <i>Time delay before trip circuit supervision operates</i>	0, 0.02 ... 59.98, 60	0.4s	

4.6.7. Inrush Detector

Description	Range	Default	Setting
Gn 81HBL2 Element <i>Selects whether the phase inrush detector 81HBL2 is enabled</i>	Disabled, Enabled	Disabled	
Gn 81HBL2 Bias <i>Selects the bias method used for magnetising inrush. Phase – Segregated, each phase blocks itself. Cross – Blocked, each phase can block the operation of other phases. Sum - Of Squares, each phase blocks itself using the square root of the sum of squares of the 2nd harmonic.</i>	Phase, Cross, Sum	Cross	
Gn 81HBL2 Setting <i>The magnetising inrush detector operates when the 2nd harmonic current exceeds a set percentage of the fundamental current</i>	0.1, 0.11 ... 0.49, 0.5	0.2xl	

4.6.8. Battery Test

Description	Range	Default	Setting
Battery Element <i>Selects whether the Battery Element is enabled</i>	Disabled, Enabled	Disabled	
Battery Nominal Voltage <i>Selects battery nominal voltage</i>	24, 30, 48, 110, 220	48V	
Battery Test Rate <i>Frequency of battery tests</i>	Every 12 Hours, Every Day ... Every Nov 1st, Every Dec 1st	Every Month 1st	
Battery Test Time <i>Hour of the day at which test will take place</i>	0, 1 ... 22, 23	12	
Battery Test Load <i>Load resistance applied during test</i>	2.5, 2.6 ... 99.9, 100	6.8ohms	
Battery Volts Drop <i>Max step change in voltage allowed when test load is applied</i>	0.5, 0.75, 1, 1.25, 1.5, 1.75, 2, 2.25, 2.5, 2.75, 3, 3.25, 3.5	2.5V	

4.6.9. Capacitor Test

Description	Range	Default	Setting
Cap Element <i>Selects whether the Capacitor Element is enabled</i>	Disabled, Enabled	Disabled	
Cap Holdup Time <i>If capacitor test load applied for this time & capacitor is still above test threshold the load test will be classed as a pass</i>	0, 0.02 ... 9.9, 10	5s	

4.6.10. Power Quality

Description	Range	Default	Setting
Gn Voltage Input Mode <i>Selects Ph-Ph or Ph-N voltages for U/V guard element & 27/59 elements operation.</i>	Ph-N, Ph-Ph	Ph-N	

4.6.11. 27SAG

Description	Range	Default	Setting
Gn 27Sag Element <i>Selects whether the 27Sag Element is enabled</i>	Disabled, Enabled	Disabled	
Gn 27Sag SARFI Threshold <i>Percentage of nominal voltage below which 27Sag SARFI is raised</i>	10, 20, 30, 40, 50, 60, 70, 80, 90	70%	
Gn 27Sag VTS Block <i>Selects whether element is blocked or not when VTS operates</i>	Disabled, Enabled	Disabled	
Gn 27Sag SIARFI Delay <i>Time below which the SIARFI count is incremented</i>	0, 0.01 ... 55, 60	0.5s	
Gn 27Sag SMARFI Delay <i>Time below which the SMARFI count is incremented, if greater than SIARFI Delay.</i>	0, 0.01 ... 55, 60	5s	
Gn 27Sag STARFI Delay <i>Time below which the STARFI count is incremented, if greater than SMARFI Delay. If voltage dip longer than this time it is classed as an interruption.</i>	0, 0.01 ... 55, 60	60s	

4.6.12. 59SWELL

Description	Range	Default	Setting
Gn 59Swell Element <i>Selects whether the 59Swell Element is enabled</i>	Disabled, Enabled	Disabled	
Gn 59Swell SARFI Threshold <i>Percentage of nominal voltage above which 59 SARFI is raised.</i>	110, 120, 130, 140	120%	
Gn 59Swell SIARFI Delay <i>Time below which the SIARFI count is incremented.</i>	0, 0.01 ... 55, 60	0.5s	
Gn 59Swell SMARFI Delay <i>Time below which the SMARFI count is incremented, if greater than SIARFI Delay</i>	0, 0.01 ... 55, 60	5s	
Gn 59Swell STARFI Delay <i>Time below which the STARFI count is incremented, if greater than SMARFI Delay.</i>	0, 0.01 ... 55, 60	60s	

4.7. Control & Logic

4.7.1. Autoreclose Prot'n

Description	Range	Default	Setting
Gn 79 P/F Inst Trips <i>Selects which phase fault protection elements are classed as Instantaneous elements and start an autoreclose sequence. These will be blocked from operating during Delayed autoreclose sequences. See autoreclose section of manual for detail of what elements can cause only Delayed protection to be used.</i>	Combination of (51-1, 51-2, 51-3, 51-4, 50-1, 50-2, 50-3, 50-4)	-----	
Gn 79 E/F Inst Trips <i>Selects which earth fault protection elements are classed as Instantaneous elements and start an autoreclose sequence. These will be blocked from operating during Delayed autoreclose sequences. See autoreclose section of manual for detail of what elements can cause only Delayed protection to be used.</i>	Combination of (51G-1, 51G-2, 51G-3, 51G-4, 50G-1, 50G-2, 50G-3, 50G-4)	-----	
Gn 79 SEF Inst Trips <i>Selects which sensitive earth fault protection elements are classed as Instantaneous elements and start an autoreclose sequence. These will be blocked from operating during Delayed autoreclose sequences. See autoreclose section of manual for detail of what elements can cause only Delayed protection to be used.</i>	Combination of (51SEF-1, 51SEF-2, 51SEF-3, 51SEF-4, 50SEF-1, 50SEF-2, 50SEF-3, 50SEF-4)	-----	
Gn 79 P/F Delayed Trips <i>Selects which phase fault protection are classed as Delayed elements, any selected elements operating will start an autoreclose sequence.</i>	Combination of (51-1, 51-2, 51-3, 51-4, 50-1, 50-2, 50-3, 50-4)	51-1, 51-2, 51-3, 51-4, 50-1, 50-2, 50-3, 50-4	
Gn 79 E/F Delayed Trips <i>Selects which earth fault protection are classed as Delayed elements, any selected elements operating will start an autoreclose sequence.</i>	Combination of (51G-1, 51G-2, 51G-3, 51G-4, 50G-1, 50G-2, 50G-3, 50G-4)	51G-1, 51G-2, 51G-3, 51G-4, 50G-1, 50G-2, 50G-3, 50G-4	
Gn 79 SEF Delayed Trips <i>Selects which sensitive earth fault elements are classed as Delayed elements, any selected elements operating will start an autoreclose sequence.</i>	Combination of (51SEF-1, 51SEF-2, 51SEF-3, 51SEF-4, 50SEF-1, 50SEF-2, 50SEF-3, 50SEF-4)	51SEF-1, 51SEF-2, 51SEF-3, 51SEF-4, 50SEF-1, 50SEF-2, 50SEF-3, 50SEF-4	
Gn 79 P/F HS Trips <i>Selects which phase fault elements are classed as High Set elements, any selected elements operating will start an autoreclose sequence.</i>	Combination of (50-1, 50-2, 50-3, 50-4)	----	

Description	Range	Default	Setting
Gn 79 E/F HS Trips <i>Selects which earth fault elements are classed as High Set elements, any selected elements operating will start an autoreclose sequence.</i>	Combination of (50G-1, 50G-2, 50G-3, 50G-4)	----	

4.7.2. Autoreclose Config

Description	Range	Default	Setting
Gn 79 Autoreclose <i>If disabled then all attempts to control the AR IN/OUT status will fail and the AR will be permanently Out Of Service. When enabled the AR IN/OUT state may be controlled via the CONTROL MODE menu option, via Binary Input or via local or remote communications.</i>	Disabled, Enabled	Disabled	
Gn 79 Num Shots <i>Selects the number of auto-reclose attempts before the Autorecloser locks out</i>	1, 2, 3, 4	1	
Gn 79 Retry Enable <i>Selects whether the Retry close functionality is enabled</i>	Disabled, Enabled	Disabled	
Gn 79 Retry Attempts <i>Selects the number of retries allowed per shot</i>	0, 1, 2, 3, 4, 5, 6, 7, 8, 9, 10	1	
Gn 79 Retry Interval <i>Time delay between retries</i>	0, 1 ... 599, 600	60s	
Gn 79 Reclose Blocked Delay <i>Specifies the maximum time that the Autorecloser can be blocked before proceeding to the lockout state. (NOTE: The block delay timer only starts after the Deadtime.)</i>	0, 1 ... 599, 600	60s	
Gn 79 Sequence Fail Timer <i>Time before lockout occurs on an incomplete reclose sequence. (i.e Trip & starter conditions have not been cleared after Sequence Fail Time.)</i>	0, 1 ... 599, 600	60s	
Gn 79 Minimum LO Delay <i>The time after entering lockout before any further external close commands are allowed.</i>	0, 1 ... 599, 600	2s	
Gn 79 Reset LO By Timer <i>Select whether Lockout is automatically reset after a time delay.</i>	Disabled, Enabled	Enabled	
Gn 79 Sequence Co-ord <i>Selects whether Sequence co-ordination functionality is used or not.</i>	Disabled, Enabled	Enabled	
Gn 79 Cold Load Action <i>Selects whether whist Cold Load is active the relay will perform only Delayed Trips or not.</i>	Off, Delayed	Off	

4.7.2.1. P/F Shots

Description	Range	Default	Setting
Gn 79 P/F Prot'n Trip 1 <i>Selects whether the first phase fault trip is Instantaneous (Fast) or Delayed. When set to Delayed all P/F Inst Trips will be Inhibited for this shot.</i>	Inst, Delayed	Inst	
Gn 79 P/F Deadtime 1 <i>Time period between the fault being cleared and the close pulse being issued</i>	0.08, 0.1 ... 14300, 14400	5s	
Gn 79 P/F Prot'n Trip 2 <i>Selects whether the second phase fault trip is Instantaneous (Fast) or Delayed. When set to Delayed all P/F Inst Trips will be Inhibited for this shot.</i>	Inst, Delayed	Inst	
Gn 79 P/F Deadtime 2 <i>Time period between the fault being cleared and the close pulse being issued</i>	2, 2.1 ... 14300, 14400	5s	
Gn 79 P/F Prot'n Trip 3 <i>Selects whether the third phase fault trip is Instantaneous (Fast) or Delayed. When set to Delayed all P/F Inst Trips will be Inhibited for this shot.</i>	Inst, Delayed	Delayed	
Gn 79 P/F Deadtime 3 <i>Time period between the fault being cleared and the close pulse being issued</i>	2, 2.1 ... 14300, 14400	5s	
Gn 79 P/F Prot'n Trip 4 <i>Selects whether the fourth phase fault trip is Instantaneous (Fast) or Delayed. When set to Delayed all P/F Inst Trips will be Inhibited for this shot.</i>	Inst, Delayed	Delayed	
Gn 79 P/F Deadtime 4 <i>Time period between the fault being cleared and the close pulse being issued</i>	30, 30.1 ... 14300, 14400	30s	
Gn 79 P/F Prot'n Trip 5 <i>Selects whether the fifth phase fault trip is Instantaneous (Fast) or Delayed. When set to Delayed all P/F Inst Trips will be Inhibited for this shot.</i>	Inst, Delayed	Delayed	
Gn 79 P/F HS Trips To Lockout <i>Selects how many High Set trips are allowed before going to Lockout</i>	1, 2, 3, 4, 5	5	
Gn 79 P/F Delayed Trips To Lockout <i>Selects how many Delayed trips are allowed before going to Lockout</i>	1, 2, 3, 4, 5	5	

4.7.2.2. E/F Shots

Description	Range	Default	Setting
Gn 79 E/F Prot'n Trip 1 <i>Selects whether the first earth fault trip is Instantaneous (Fast) or Delayed. When set to Delayed all E/F Inst Trips will be Inhibited for this shot.</i>	Inst, Delayed	Inst	

Description	Range	Default	Setting
Gn 79 E/F Deadtime 1 <i>Time period between the fault being cleared and the close pulse being issued</i>	0.08, 0.1 ... 14300, 14400	5s	
Gn 79 E/F Prot'n Trip 2 <i>Selects whether the second earth fault trip is Instantaneous (Fast) or Delayed. When set to Delayed all E/F Inst Trips will be Inhibited for this shot.</i>	Inst, Delayed	Inst	
Gn 79 E/F Deadtime 2 <i>Time period between the fault being cleared and the close pulse being issued</i>	2, 2.1 ... 14300, 14400	5s	
Gn 79 E/F Prot'n Trip 3 <i>Selects whether the third earth fault trip is Instantaneous (Fast) or Delayed. When set to Delayed all E/F Inst Trips will be Inhibited for this shot.</i>	Inst, Delayed	Delayed	
Gn 79 E/F Deadtime 3 <i>Time period between the fault being cleared and the close pulse being issued</i>	2, 2.1 ... 14300, 14400	5s	
Gn 79 E/F Prot'n Trip 4 <i>Selects whether the fourth earth fault trip is Instantaneous (Fast) or Delayed. When set to Delayed all E/F Inst Trips will be Inhibited for this shot.</i>	Inst, Delayed	Delayed	
Gn 79 E/F Deadtime 4 <i>Time period between the fault being cleared and the close pulse being issued</i>	30, 30.1 ... 14300, 14400	30s	
Gn 79 E/F Prot'n Trip 5 <i>Selects whether the fifth earth fault trip is Instantaneous (Fast) or Delayed. When set to Delayed all E/F Inst Trips will be Inhibited for this shot.</i>	Inst, Delayed	Delayed	
Gn 79 E/F HS Trips To Lockout <i>Selects how many High Set trips are allowed before going to Lockout</i>	1, 2, 3, 4, 5	5	
Gn 79 E/F Delayed Trips To Lockout <i>Selects how many Delayed trips are allowed before going to Lockout</i>	1, 2, 3, 4, 5	5	

4.7.2.3. SEF Shots

Description	Range	Default	Setting
Gn 79 SEF Prot'n Trip 1 <i>Selects whether the first sensitive earth fault trip is Instantaneous or Delayed. When set to Delayed all SEF Inst Trips will be Inhibited for this shot.</i>	Inst, Delayed	Inst	
Gn 79 SEF Deadtime 1 <i>Time period between the fault being cleared and the close pulse being issued</i>	0.08, 0.1 ... 14300, 14400	5s	
Gn 79 SEF Prot'n Trip 2 <i>Selects whether the second sensitive earth fault trip is Instantaneous or Delayed. When set to Delayed all SEF Inst Trips will be Inhibited for this shot.</i>	Inst, Delayed	Inst	

Description	Range	Default	Setting
Gn 79 SEF Deadtime 2 <i>Time period between the fault being cleared and the close pulse being issued</i>	2, 2.1 ... 14300, 14400	5s	
Gn 79 SEF Prot'n Trip 3 <i>Selects whether the third sensitive earth fault trip is Instantaneous or Delayed. When set to Delayed all SEF Inst Trips will be Inhibited for this shot.</i>	Inst, Delayed	Delayed	
Gn 79 SEF Deadtime 3 <i>Time period between the fault being cleared and the close pulse being issued</i>	2, 2.1 ... 14300, 14400	5s	
Gn 79 SEF Prot'n Trip 4 <i>Selects whether the fourth sensitive earth fault trip is Instantaneous or Delayed. When set to Delayed all SEF Inst Trips will be Inhibited for this shot.</i>	Inst, Delayed	Delayed	
Gn 79 SEF Deadtime 4 <i>Time period between the fault being cleared and the close pulse being issued</i>	30, 30.1 ... 14300, 14400	30s	
Gn 79 SEF Prot'n Trip 5 <i>Selects whether the fifth sensitive earth fault trip is Instantaneous or Delayed. When set to Delayed all SEF Inst Trips will be Inhibited for this shot.</i>	Inst, Delayed	Delayed	
Gn 79 SEF Delayed Trips To Lockout <i>Selects how many Delayed trips are allowed before going to Lockout</i>	1, 2, 3, 4, 5	5	

4.7.2.4. Extern Shots

Description	Range	Default	Setting
Gn 79 Extern Prot'n Trip 1 <i>Selects whether the first external trip is Instantaneous or Delayed</i>	Not Blocked, Blocked	Not Blocked	
Gn 79 Extern Deadtime 1 <i>Time period between the fault being cleared and the close pulse being issued</i>	0.08, 0.1 ... 14300, 14400	5s	
Gn 79 Extern Prot'n Trip 2 <i>Selects whether the second external trip is Instantaneous or Delayed</i>	Not Blocked, Blocked	Not Blocked	
Gn 79 Extern Deadtime 2 <i>Time period between the fault being cleared and the close pulse being issued</i>	2, 2.1 ... 14300, 14400	5s	
Gn 79 Extern Prot'n Trip 3 <i>Selects whether the third external trip is Instantaneous or Delayed</i>	Not Blocked, Blocked	Not Blocked	
Gn 79 Extern Deadtime 3 <i>Time period between the fault being cleared and the close pulse being issued</i>	2, 2.1 ... 14300, 14400	5s	
Gn 79 Extern Prot'n Trip 4 <i>Selects whether the fourth external trip is Instantaneous or Delayed</i>	Not Blocked, Blocked	Not Blocked	
Gn 79 Extern Deadtime 4 <i>Time period between the fault being cleared and the close pulse being issued</i>	30, 30.1 ... 14300, 14400	30s	

Description	Range	Default	Setting
Gn 79 Extern Prot'n Trip 5 <i>Selects whether the fifth external trip is Instantaneous or Delayed</i>	Not Blocked, Blocked	Not Blocked	
Gn 79 Extern Trips To Lockout <i>Selects how many external trips are allowed before going to Lockout</i>	1, 2, 3, 4, 5	5	

4.7.3. Manual Close

Description	Range	Default	Setting
Gn Line Check Trip <i>Selects whether line check trip is enabled, if enabled no AR sequence initiated</i>	Disabled, Enabled	Enabled	
Gn P/F Line Check Trip <i>Selects whether a phase fault line check trip is Instantaneous (Fast) or Delayed. When set to Delayed all P/F Inst Trips will be Inhibited for this shot.</i>	Inst, Delayed	Inst	
Gn E/F Line Check Trip <i>Selects whether an earth fault line check trip is Instantaneous or Delayed. When set to Delayed all E/F Inst Trips will be Inhibited for this shot.</i>	Inst, Delayed	Inst	
Gn SEF Line Check Trip <i>Selects whether a sensitive earth fault line check trip is Instantaneous or Delayed. When set to Delayed all SEF Inst Trips will be Inhibited for this shot.</i>	Inst, Delayed	Inst	
Gn Extern Line Check Trip <i>Selects whether an external line check trip is Instantaneous (Fast) or Delayed</i>	Not Blocked, Blocked	Not Blocked	

4.7.4. Circuit Breaker

Description	Range	Default	Setting
Gn Close CB Delay <i>Delay between a Close CB control being received and the Close CB contacts being operated to allow operator walk away.</i>	0, 1 ... 59900, 60000	10000ms	
Gn Close CB Pulse <i>Specifies the duration of the circuit breaker close pulse</i>	0.1, 0.2 ... 59.9, 60	2s	
Gn Reclaim Timer <i>The period of time after a CB has closed and remained closed before the reclosure is deemed to be successful and the AR is re-initialised. If the CB remains open at the end of the reclaim time then the AR goes to lockout.</i>	0, 1 ... 599, 600	2s	
Gn Blocked Close Delay <i>Selects the maximum time that the manual Close CB may be blocked by interlocking before the command or control is cancelled. The relay will signal "Blocked by Interlocking".</i>	0, 1 ... 599, 600	5s	

Description	Range	Default	Setting
Gn Open CB Delay <i>Delay between an Open CB control being received and the Open CB contacts being operated.</i>	0, 1 ... 59900, 60000	10000ms	
Gn Open CB Pulse <i>Selects the maximum time of the Open CB pulse. If the CB is not closed when this timer expires then an alarm will be raised to signify failure to close.</i>	0.1, 0.2, 0.3, 0.4, 0.5, 0.6, 0.7, 0.8, 0.9, 1, 1.1, 1.2, 1.3, 1.4, 1.5, 1.6, 1.7, 1.8, 1.9, 2	1s	
Gn CB Travel Alarm <i>Selects the maximum time that the CB should take to either Open or Close before a failure is recorded.</i>	0.01, 0.02 ... 1.99, 2	1s	
Gn CB Controls Latched <i>Selects whether Binary Input triggers of Close CB and Open CB are latched.</i>	Disabled, Enabled	Enabled	

4.7.5. LOV Automation

Description	Range	Default	Setting
Gn LOV-A Live <i>Voltage above which the A Side is classed as Live.</i>	5, 5.5 ... 79.5, 80	50V	
Gn LOV-A Dead <i>Voltage below which the A Side is classed as Dead.</i>	5, 5.5 ... 79.5, 80	10V	
Gn LOV-X Live <i>Voltage above which the X Side is classed as Live.</i>	5, 5.5 ... 79.5, 80	50V	
Gn LOV-X Dead <i>Voltage below which the X Side is classed as Dead.</i>	5, 5.5 ... 79.5, 80	10V	
Gn LOV Automation <i>When set to Disabled, no LOV Automation elements will be functional and all associated settings will be hidden. (The Setting Dependencies setting being set to Disabled will make all settings visible but will not allow them to operate).</i>	Disabled, Enabled	Disabled	
Gn LOV Plant Device Type <i>Selects the appropriate functionality for the type of device.</i>	NOP(TIE), Feeder, Recloser	Recloser	
Gn LOV Start Option <i>The required voltage loss can be single phase or all phases.</i>	All Dead, Any Dead	All Dead	
Gn LOV Primed Interlock <i>When set to Enabled, the correct voltage & CB position must be seen before the LOV element will Prime, when Disabled only correct CB position is required.</i>	Disabled, Enabled	Enabled	
Gn LOV Primed Time <i>Time that the primed condition has to be present for before the LOV Automation is classed as primed.</i>	0, 1 ... 599, 600	5s	

Description	Range	Default	Setting
Gn LOV Recloser Opening <i>Select if a Recloser Type should open after LOV and reclose once voltage is restored or stay closed whilst waiting for voltage to be restored.</i>	Disabled, Enabled	Disabled	
Gn LOV Action Delay <i>After Loss of Voltage for this length of time the LOV action starts. (Recloser & Feeder)</i>	0, 1 ... 599, 600	60s	
Gn LOV-A Action <i>Select whether the NOP is to operate for Loss of voltage on the A Side.</i>	Disabled, Enabled	Enabled	
Gn LOV-A Action Delay <i>After the Loss of Voltage on the A Side for this length of time the LOV action starts. (NOP)</i>	0, 1 ... 599, 600	60s	
Gn LOV-X Action <i>Select whether the NOP is to operate for Loss of voltage on the X Side.</i>	Disabled, Enabled	Enabled	
Gn LOV-X Action Delay <i>After the Loss of Voltage on the X Side for this length of time the LOV action starts. (NOP)</i>	0, 1 ... 599, 600	60s	
Gn LOV Sequence Time <i>Time allowed after LOV Action Delay for a NOP to close and Voltage to reappear.</i>	0, 1 ... 599, 600	60s	
Gn LOV Reclose Delay <i>When "Gn LOV Recloser Opening" is Enabled, the voltage must be re-established for this length of time before the Recloser will close.</i>	0, 1 ... 599, 600	5s	
Gn LOV SOTF Time <i>For this length of time after a recloser has been closed, due to an LOV Automation operation, all Instantaneous protections will be allowed to operate.</i>	0, 1 ... 599, 600	5s	
Gn LOV Reclaim Time <i>For this length of time after the "Gn LOV SOTF Time" all Instantaneous protections will be inhibited.</i>	0, 1 ... 599, 600	60s	
Gn LOV Memory Time <i>Length of time that NOP will remain primed for after losing voltage on both sides.</i>	0, 1 ... 599, 600	60s	
Gn LOV Operation <i>LOV sequences can be single shot or repeated.</i>	Multi, Single	Multi	

4.7.6. Quick Logic

Description	Range	Default	Setting
Quick Logic <i>Enable or Disable all logic equations</i>	Disabled, Enabled	Disabled	
E1 Equation <i>Enable or Disable logic equation E1</i>	Disabled, Enabled	Disabled	

Description	Range	Default	Setting
<p>E1</p> <p>Specify logic equations of the form $E_n = \langle \text{Operand} \rangle \langle \text{Operator} \rangle \langle \text{Operand} \rangle$ using the following: 0123456789=Digit() = Parenthesis! = NOT operation. = AND operation ^ = EXCLUSIVE OR operation E (followed by a digit) = Equation number F (Followed by a digit) = Function Key number I (Followed by a digit) = Binary Input number L (Followed by a digit) = LED number O (Followed by a digit) = output relay number V (Followed by a digit) = Virtual Input/Output number. Examples Make a function key LED toggle when function key is pressed (requires E1 to drive L11 in output matrix) $E1 = F3 \wedge L11$</p>	(20 Character String)		
<p>E1 Pickup Delay</p> <p>Time before equation output operates, after equation satisfied</p>	0, 0.01 ... 14300, 14400	0s	
<p>E1 Dropoff Delay</p> <p>Time before equation output resets, after equation no longer satisfied</p>	0, 0.01 ... 14300, 14400	0s	
<p>E1 Counter Target</p> <p>Select number of times equation must be satisfied before equation output operates</p>	1, 2 ... 998, 999	1	
<p>E1 Counter Reset Mode</p> <p>Select type of counter reset mode</p>	Off, Multi-shot, Single-shot	Off	
<p>E1 Counter Reset Time</p> <p>Select counter reset time</p>	0, 0.01 ... 14300, 14400	0s	
<p>E2 Equation</p> <p>Enable or Disable logic equation E2</p>	Disabled, Enabled	Disabled	
<p>E2</p> <p>Specify logic equations of the form $E_n = \langle \text{Operand} \rangle \langle \text{Operator} \rangle \langle \text{Operand} \rangle$ using the following: 0123456789=Digit() = Parenthesis! = NOT operation. = AND operation ^ = EXCLUSIVE OR operation E (followed by a digit) = Equation number F (Followed by a digit) = Function Key number I (Followed by a digit) = Binary Input number L (Followed by a digit) = LED number O (Followed by a digit) = output relay number V (Followed by a digit) = Virtual Input/Output number. Examples Make a function key LED toggle when function key is pressed (requires E1 to drive L11 in output matrix) $E1 = F3 \wedge L11$</p>	(20 Character String)		
<p>E2 Pickup Delay</p> <p>Time before equation output operates, after equation satisfied</p>	0, 0.01 ... 14300, 14400	0s	
<p>E2 Dropoff Delay</p> <p>Time before equation output resets, after equation no longer satisfied</p>	0, 0.01 ... 14300, 14400	0s	
<p>E2 Counter Target</p> <p>Select number of times equation must be satisfied before equation output operates</p>	1, 2 ... 998, 999	1	
<p>E2 Counter Reset Mode</p> <p>Select type of counter reset mode</p>	Off, Multi-shot, Single-shot	Off	

Description	Range	Default	Setting
E2 Counter Reset Time <i>Select counter reset time</i>	0, 0.01 ... 14300, 14400	0s	
E3 Equation <i>Enable or Disable logic equation E3</i>	Disabled, Enabled	Disabled	
E3 <i>Specify logic equations of the form En = <Operand><Operator><Operand>using the following:0123456789=Digit() = Parenthesis! = NOT operation. = AND operation^ = EXCLUSIVE OR operationE(followed by a digit) = Equation numberF (Followed by a digit) = Function Key numberI(Followed by a digit) = Binary Input numberL(Followed by a digit) = LED numberO(Followed by a digit) = output relay numberV(Followed by a digit) =Virtual Input/Output number.ExamplesMake a function key LED toggle when function key is pressed (requires E1 to drive L11 in output matrix)E1 = F3^L11</i>	(20 Character String)		
E3 Pickup Delay <i>Time before equation output operates, after equation satisfied</i>	0, 0.01 ... 14300, 14400	0s	
E3 Dropoff Delay <i>Time before equation output resets, after equation no longer satisfied</i>	0, 0.01 ... 14300, 14400	0s	
E3 Counter Target <i>Select number of times equation must be satisfied before equation output operates</i>	1, 2 ... 998, 999	1	
E3 Counter Reset Mode <i>Select type of counter reset mode</i>	Off, Multi-shot, Single-shot	Off	
E3 Counter Reset Time <i>Select counter reset time</i>	0, 0.01 ... 14300, 14400	0s	
E4 Equation <i>Enable or Disable logic equation E4</i>	Disabled, Enabled	Disabled	
E4 <i>Specify logic equations of the form En = <Operand><Operator><Operand>using the following:0123456789=Digit() = Parenthesis! = NOT operation. = AND operation^ = EXCLUSIVE OR operationE(followed by a digit) = Equation numberF (Followed by a digit) = Function Key numberI(Followed by a digit) = Binary Input numberL(Followed by a digit) = LED numberO(Followed by a digit) = output relay numberV(Followed by a digit) =Virtual Input/Output number.ExamplesMake a function key LED toggle when function key is pressed (requires E1 to drive L11 in output matrix)E1 = F3^L11</i>	(20 Character String)		
E4 Pickup Delay <i>Time before equation output operates, after equation satisfied</i>	0, 0.01 ... 14300, 14400	0s	
E4 Dropoff Delay <i>Time before equation output resets, after equation no longer satisfied</i>	0, 0.01 ... 14300, 14400	0s	

Description	Range	Default	Setting
E4 Counter Target <i>Select number of times equation must be satisfied before equation output operates</i>	1, 2 ... 998, 999	1	
E4 Counter Reset Mode <i>Select type of counter reset mode</i>	Off, Multi-shot, Single-shot	Off	
E4 Counter Reset Time <i>Select counter reset time</i>	0, 0.01 ... 14300, 14400	0s	
E5 Equation <i>Enable or Disable logic equation E5</i>	Disabled, Enabled	Disabled	
E5 <i>Specify logic equations of the form En = <Operand><Operator><Operand>using the following:0123456789=Digit() = Parenthesis! = NOT operation. = AND operation^ = EXCLUSIVE OR operationE(followed by a digit) = Equation numberF (Followed by a digit) = Function Key numberI(Followed by a digit) = Binary Input numberL(Followed by a digit) = LED numberO(Followed by a digit) = output relay numberV(Followed by a digit) =Virtual Input/Output number.ExamplesMake a function key LED toggle when function key is pressed (requires E1 to drive L11 in output matrix)E1 = F3^L11</i>	(20 Character String)		
E5 Pickup Delay <i>Time before equation output operates, after equation satisfied</i>	0, 0.01 ... 14300, 14400	0s	
E5 Droptoff Delay <i>Time before equation output resets, after equation no longer satisfied</i>	0, 0.01 ... 14300, 14400	0s	
E5 Counter Target <i>Select number of times equation must be satisfied before equation output operates</i>	1, 2 ... 998, 999	1	
E5 Counter Reset Mode <i>Select type of counter reset mode</i>	Off, Multi-shot, Single-shot	Off	
E5 Counter Reset Time <i>Select counter reset time</i>	0, 0.01 ... 14300, 14400	0s	
E6 Equation <i>Enable or Disable logic equation E6</i>	Disabled, Enabled	Disabled	
E6 <i>Specify logic equations of the form En = <Operand><Operator><Operand>using the following:0123456789=Digit() = Parenthesis! = NOT operation. = AND operation^ = EXCLUSIVE OR operationE(followed by a digit) = Equation numberF (Followed by a digit) = Function Key numberI(Followed by a digit) = Binary Input numberL(Followed by a digit) = LED numberO(Followed by a digit) = output relay numberV(Followed by a digit) =Virtual Input/Output number.ExamplesMake a function key LED toggle when function key is pressed (requires E1 to drive L11 in output matrix)E1 = F3^L11</i>	(20 Character String)		

Description	Range	Default	Setting
E6 Pickup Delay <i>Time before equation output operates, after equation satisfied</i>	0, 0.01 ... 14300, 14400	0s	
E6 Dropoff Delay <i>Time before equation output resets, after equation no longer satisfied</i>	0, 0.01 ... 14300, 14400	0s	
E6 Counter Target <i>Select number of times equation must be satisfied before equation output operates</i>	1, 2 ... 998, 999	1	
E6 Counter Reset Mode <i>Select type of counter reset mode</i>	Off, Multi-shot, Single-shot	Off	
E6 Counter Reset Time <i>Select counter reset time</i>	0, 0.01 ... 14300, 14400	0s	
E7 Equation <i>Enable or Disable logic equation E7</i>	Disabled, Enabled	Disabled	
E7 <i>Specify logic equations of the form En = <Operand><Operator><Operand> using the following: 0123456789=Digit() = Parenthesis! = NOT operation. = AND operation ^ = EXCLUSIVE OR operation E (followed by a digit) = Equation number F (Followed by a digit) = Function Key number L (Followed by a digit) = Binary Input number L (Followed by a digit) = LED number O (Followed by a digit) = output relay number V (Followed by a digit) = Virtual Input/Output number. Examples Make a function key LED toggle when function key is pressed (requires E1 to drive L11 in output matrix) E1 = F3^L11</i>	(20 Character String)		
E7 Pickup Delay <i>Time before equation output operates, after equation satisfied</i>	0, 0.01 ... 14300, 14400	0s	
E7 Dropoff Delay <i>Time before equation output resets, after equation no longer satisfied</i>	0, 0.01 ... 14300, 14400	0s	
E7 Counter Target <i>Select number of times equation must be satisfied before equation output operates</i>	1, 2 ... 998, 999	1	
E7 Counter Reset Mode <i>Select type of counter reset mode</i>	Off, Multi-shot, Single-shot	Off	
E7 Counter Reset Time <i>Select counter reset time</i>	0, 0.01 ... 14300, 14400	0s	
E8 Equation <i>Enable or Disable logic equation E8</i>	Disabled, Enabled	Disabled	

Description	Range	Default	Setting
E8 Specify logic equations of the form $E_n = \langle \text{Operand} \rangle \langle \text{Operator} \rangle \langle \text{Operand} \rangle$ using the following: 0123456789=Digit() = Parenthesis! = NOT operation. = AND operation ^ = EXCLUSIVE OR operation E (followed by a digit) = Equation number F (Followed by a digit) = Function Key number I (Followed by a digit) = Binary Input number L (Followed by a digit) = LED number O (Followed by a digit) = output relay number V (Followed by a digit) = Virtual Input/Output number. Examples Make a function key LED toggle when function key is pressed (requires E1 to drive L11 in output matrix) $E1 = F3 \wedge L11$	(20 Character String)		
E8 Pickup Delay Time before equation output operates, after equation satisfied	0, 0.01 ... 14300, 14400	0s	
E8 Dropoff Delay Time before equation output resets, after equation no longer satisfied	0, 0.01 ... 14300, 14400	0s	
E8 Counter Target Select number of times equation must be satisfied before equation output operates	1, 2 ... 998, 999	1	
E8 Counter Reset Mode Select type of counter reset mode	Off, Multi-shot, Single-shot	Off	
E8 Counter Reset Time Select counter reset time	0, 0.01 ... 14300, 14400	0s	
E9 Equation Enable or Disable logic equation E9	Disabled, Enabled	Disabled	
E9 Specify logic equations of the form $E_n = \langle \text{Operand} \rangle \langle \text{Operator} \rangle \langle \text{Operand} \rangle$ using the following: 0123456789=Digit() = Parenthesis! = NOT operation. = AND operation ^ = EXCLUSIVE OR operation E (followed by a digit) = Equation number F (Followed by a digit) = Function Key number I (Followed by a digit) = Binary Input number L (Followed by a digit) = LED number O (Followed by a digit) = output relay number V (Followed by a digit) = Virtual Input/Output number. Examples Make a function key LED toggle when function key is pressed (requires E1 to drive L11 in output matrix) $E1 = F3 \wedge L11$	(20 Character String)		
E9 Pickup Delay Time before equation output operates, after equation satisfied	0, 0.01 ... 14300, 14400	0s	
E9 Dropoff Delay Time before equation output resets, after equation no longer satisfied	0, 0.01 ... 14300, 14400	0s	
E9 Counter Target Select number of times equation must be satisfied before equation output operates	1, 2 ... 998, 999	1	
E9 Counter Reset Mode Select type of counter reset mode	Off, Multi-shot, Single-shot	Off	

Description	Range	Default	Setting
E9 Counter Reset Time <i>Select counter reset time</i>	0, 0.01 ... 14300, 14400	0s	
E10 Equation <i>Enable or Disable logic equation E10</i>	Disabled, Enabled	Disabled	
E10 <i>Specify logic equations of the form En = <Operand><Operator><Operand>using the following:0123456789=Digit() = Parenthesis! = NOT operation. = AND operation^ = EXCLUSIVE OR operationE(followed by a digit) = Equation numberF (Followed by a digit) = Function Key numberI(Followed by a digit) = Binary Input numberL(Followed by a digit) = LED numberO(Followed by a digit) = output relay numberV(Followed by a digit) =Virtual Input/Output number.ExamplesMake a function key LED toggle when function key is pressed (requires E1 to drive L11 in output matrix)E1 = F3^L11</i>	(20 Character String)		
E10 Pickup Delay <i>Time before equation output operates, after equation satisfied</i>	0, 0.01 ... 14300, 14400	0s	
E10 Dropoff Delay <i>Time before equation output resets, after equation no longer satisfied</i>	0, 0.01 ... 14300, 14400	0s	
E10 Counter Target <i>Select number of times equation must be satisfied before equation output operates</i>	1, 2 ... 998, 999	1	
E10 Counter Reset Mode <i>Select type of counter reset mode</i>	Off, Multi-shot, Single-shot	Off	
E10 Counter Reset Time <i>Select counter reset time</i>	0, 0.01 ... 14300, 14400	0s	
E11 Equation <i>Enable or Disable logic equation E11</i>	Disabled, Enabled	Disabled	
E11 <i>Specify logic equations of the form En = <Operand><Operator><Operand>using the following:0123456789=Digit() = Parenthesis! = NOT operation. = AND operation^ = EXCLUSIVE OR operationE(followed by a digit) = Equation numberF (Followed by a digit) = Function Key numberI(Followed by a digit) = Binary Input numberL(Followed by a digit) = LED numberO(Followed by a digit) = output relay numberV(Followed by a digit) =Virtual Input/Output number.ExamplesMake a function key LED toggle when function key is pressed (requires E1 to drive L11 in output matrix)E1 = F3^L11</i>	(20 Character String)		
E11 Pickup Delay <i>Time before equation output operates, after equation satisfied</i>	0, 0.01 ... 14300, 14400	0s	
E11 Dropoff Delay <i>Time before equation output resets, after equation no longer satisfied</i>	0, 0.01 ... 14300, 14400	0s	

Description	Range	Default	Setting
E11 Counter Target <i>Select number of times equation must be satisfied before equation output operates</i>	1, 2 ... 998, 999	1	
E11 Counter Reset Mode <i>Select type of counter reset mode</i>	Off, Multi-shot, Single-shot	Off	
E11 Counter Reset Time <i>Select counter reset time</i>	0, 0.01 ... 14300, 14400	0s	
E12 Equation <i>Enable or Disable logic equation E12</i>	Disabled, Enabled	Disabled	
E12 <i>Specify logic equations of the form En = <Operand><Operator><Operand>using the following:0123456789=Digit() = Parenthesis! = NOT operation. = AND operation^ = EXCLUSIVE OR operationE(followed by a digit) = Equation numberF (Followed by a digit) = Function Key numberI(Followed by a digit) = Binary Input numberL(Followed by a digit) = LED numberO(Followed by a digit) = output relay numberV(Followed by a digit) =Virtual Input/Output number.ExamplesMake a function key LED toggle when function key is pressed (requires E1 to drive L11 in output matrix)E1 = F3^L11</i>	(20 Character String)		
E12 Pickup Delay <i>Time before equation output operates, after equation satisfied</i>	0, 0.01 ... 14300, 14400	0s	
E12 Dropoff Delay <i>Time before equation output resets, after equation no longer satisfied</i>	0, 0.01 ... 14300, 14400	0s	
E12 Counter Target <i>Select number of times equation must be satisfied before equation output operates</i>	1, 2 ... 998, 999	1	
E12 Counter Reset Mode <i>Select type of counter reset mode</i>	Off, Multi-shot, Single-shot	Off	
E12 Counter Reset Time <i>Select counter reset time</i>	0, 0.01 ... 14300, 14400	0s	
E13 Equation <i>Enable or Disable logic equation E13</i>	Disabled, Enabled	Disabled	
E13 <i>Specify logic equations of the form En = <Operand><Operator><Operand>using the following:0123456789=Digit() = Parenthesis! = NOT operation. = AND operation^ = EXCLUSIVE OR operationE(followed by a digit) = Equation numberF (Followed by a digit) = Function Key numberI(Followed by a digit) = Binary Input numberL(Followed by a digit) = LED numberO(Followed by a digit) = output relay numberV(Followed by a digit) =Virtual Input/Output number.ExamplesMake a function key LED toggle when function key is pressed (requires E1 to drive L11 in output matrix)E1 = F3^L11</i>	(20 Character String)		

Description	Range	Default	Setting
E13 Pickup Delay <i>Time before equation output operates, after equation satisfied</i>	0, 0.01 ... 14300, 14400	0s	
E13 Dropoff Delay <i>Time before equation output resets, after equation no longer satisfied</i>	0, 0.01 ... 14300, 14400	0s	
E13 Counter Target <i>Select number of times equation must be satisfied before equation output operates</i>	1, 2 ... 998, 999	1	
E13 Counter Reset Mode <i>Select type of counter reset mode</i>	Off, Multi-shot, Single-shot	Off	
E13 Counter Reset Time <i>Select counter reset time</i>	0, 0.01 ... 14300, 14400	0s	
E14 Equation <i>Enable or Disable logic equation E14</i>	Disabled, Enabled	Disabled	
E14 <i>Specify logic equations of the form En = <Operand><Operator><Operand> using the following: 0123456789=Digit() = Parenthesis! = NOT operation. = AND operation ^ = EXCLUSIVE OR operation E (followed by a digit) = Equation number F (Followed by a digit) = Function Key number L (Followed by a digit) = Binary Input number L (Followed by a digit) = LED number O (Followed by a digit) = output relay number V (Followed by a digit) = Virtual Input/Output number. Examples Make a function key LED toggle when function key is pressed (requires E1 to drive L11 in output matrix) E1 = F3^L11</i>	(20 Character String)		
E14 Pickup Delay <i>Time before equation output operates, after equation satisfied</i>	0, 0.01 ... 14300, 14400	0s	
E14 Dropoff Delay <i>Time before equation output resets, after equation no longer satisfied</i>	0, 0.01 ... 14300, 14400	0s	
E14 Counter Target <i>Select number of times equation must be satisfied before equation output operates</i>	1, 2 ... 998, 999	1	
E14 Counter Reset Mode <i>Select type of counter reset mode</i>	Off, Multi-shot, Single-shot	Off	
E14 Counter Reset Time <i>Select counter reset time</i>	0, 0.01 ... 14300, 14400	0s	
E15 Equation <i>Enable or Disable logic equation E15</i>	Disabled, Enabled	Disabled	

Description	Range	Default	Setting
E15 Specify logic equations of the form $E_n = \langle \text{Operand} \rangle \langle \text{Operator} \rangle \langle \text{Operand} \rangle$ using the following: 0123456789=Digit() = Parenthesis! = NOT operation. = AND operation ^ = EXCLUSIVE OR operation E (followed by a digit) = Equation number F (Followed by a digit) = Function Key number I (Followed by a digit) = Binary Input number L (Followed by a digit) = LED number O (Followed by a digit) = output relay number V (Followed by a digit) = Virtual Input/Output number. Examples Make a function key LED toggle when function key is pressed (requires E1 to drive L11 in output matrix) $E1 = F3 \wedge L11$	(20 Character String)		
E15 Pickup Delay Time before equation output operates, after equation satisfied	0, 0.01 ... 14300, 14400	0s	
E15 Dropoff Delay Time before equation output resets, after equation no longer satisfied	0, 0.01 ... 14300, 14400	0s	
E15 Counter Target Select number of times equation must be satisfied before equation output operates	1, 2 ... 998, 999	1	
E15 Counter Reset Mode Select type of counter reset mode	Off, Multi-shot, Single-shot	Off	
E15 Counter Reset Time Select counter reset time	0, 0.01 ... 14300, 14400	0s	
E16 Equation Enable or Disable logic equation E16	Disabled, Enabled	Disabled	
E16 Specify logic equations of the form $E_n = \langle \text{Operand} \rangle \langle \text{Operator} \rangle \langle \text{Operand} \rangle$ using the following: 0123456789=Digit() = Parenthesis! = NOT operation. = AND operation ^ = EXCLUSIVE OR operation E (followed by a digit) = Equation number F (Followed by a digit) = Function Key number I (Followed by a digit) = Binary Input number L (Followed by a digit) = LED number O (Followed by a digit) = output relay number V (Followed by a digit) = Virtual Input/Output number. Examples Make a function key LED toggle when function key is pressed (requires E1 to drive L11 in output matrix) $E1 = F3 \wedge L11$	(20 Character String)		
E16 Pickup Delay Time before equation output operates, after equation satisfied	0, 0.01 ... 14300, 14400	0s	
E16 Dropoff Delay Time before equation output resets, after equation no longer satisfied	0, 0.01 ... 14300, 14400	0s	
E16 Counter Target Select number of times equation must be satisfied before equation output operates	1, 2 ... 998, 999	1	
E16 Counter Reset Mode Select type of counter reset mode	Off, Multi-shot, Single-shot	Off	

Description	Range	Default	Setting
E16 Counter Reset Time <i>Select counter reset time</i>	0, 0.01 ... 14300, 14400	0s	

4.8. Input Config

4.8.1. Input Matrix

Description	Range	Default	Setting
Inhibit 51-1 <i>Selects which inputs inhibit the 51-1 element</i>	Combination of (BI1, BI2, BI3, BI4, BI5, BI6, BI7, BI8, BI9, BI10, BI11, BI12, BI13, BI14, BI15, BI16, BI17, BI18, BI19, BI20, BI21, BI22, BI23, V1, V2, V3, V4, V5, V6, V7, V8, V9, V10, V11, V12, V13, V14, V15, V16)	----- ----- ---	
Inhibit 51-2 <i>Selects which inputs inhibit the 51-2 element</i>	Combination of (BI1, BI2, BI3, BI4, BI5, BI6, BI7, BI8, BI9, BI10, BI11, BI12, BI13, BI14, BI15, BI16, BI17, BI18, BI19, BI20, BI21, BI22, BI23, V1, V2, V3, V4, V5, V6, V7, V8, V9, V10, V11, V12, V13, V14, V15, V16)	----- ----- ---	
Inhibit 51-3 <i>Selects which inputs inhibit the 51-3 element</i>	Combination of (BI1, BI2, BI3, BI4, BI5, BI6, BI7, BI8, BI9, BI10, BI11, BI12, BI13, BI14, BI15, BI16, BI17, BI18, BI19, BI20, BI21, BI22, BI23, V1, V2, V3, V4, V5, V6, V7, V8, V9, V10, V11, V12, V13, V14, V15, V16)	----- ----- ---	
Inhibit 51-4 <i>Selects which inputs inhibit the 51-4 element</i>	Combination of (BI1, BI2, BI3, BI4, BI5, BI6, BI7, BI8, BI9, BI10, BI11, BI12, BI13, BI14, BI15, BI16, BI17, BI18, BI19, BI20, BI21, BI22, BI23, V1, V2, V3, V4, V5, V6, V7, V8, V9, V10, V11, V12, V13, V14, V15, V16)	----- ----- ---	
Inhibit 50-1 <i>Selects which inputs inhibit the 50-1 element</i>	Combination of (BI1, BI2, BI3, BI4, BI5, BI6, BI7, BI8, BI9, BI10, BI11, BI12, BI13, BI14, BI15, BI16, BI17, BI18, BI19, BI20, BI21, BI22, BI23, V1, V2, V3, V4, V5, V6, V7, V8, V9, V10, V11, V12, V13, V14, V15, V16)	----- ----- ---	
Inhibit 50-2 <i>Selects which inputs inhibit the 50-2 element</i>	Combination of (BI1, BI2, BI3, BI4, BI5, BI6, BI7, BI8, BI9, BI10, BI11, BI12, BI13, BI14, BI15, BI16, BI17, BI18, BI19, BI20, BI21, BI22, BI23, V1, V2, V3, V4, V5, V6, V7, V8, V9, V10, V11, V12, V13, V14, V15, V16)	----- ----- ---	

Description	Range	Default	Setting
Inhibit 50-3 <i>Selects which inputs inhibit the 50-3 element</i>	Combination of (BI1, BI2, BI3, BI4, BI5, BI6, BI7, BI8, BI9, BI10, BI11, BI12, BI13, BI14, BI15, BI16, BI17, BI18, BI19, BI20, BI21, BI22, BI23, V1, V2, V3, V4, V5, V6, V7, V8, V9, V10, V11, V12, V13, V14, V15, V16)	----- ----- ---	
Inhibit 50-4 <i>Selects which inputs inhibit the 50-4 element</i>	Combination of (BI1, BI2, BI3, BI4, BI5, BI6, BI7, BI8, BI9, BI10, BI11, BI12, BI13, BI14, BI15, BI16, BI17, BI18, BI19, BI20, BI21, BI22, BI23, V1, V2, V3, V4, V5, V6, V7, V8, V9, V10, V11, V12, V13, V14, V15, V16)	----- ----- ---	
Inhibit 51G-1 <i>Selects which inputs inhibit the 51G-1 element</i>	Combination of (BI1, BI2, BI3, BI4, BI5, BI6, BI7, BI8, BI9, BI10, BI11, BI12, BI13, BI14, BI15, BI16, BI17, BI18, BI19, BI20, BI21, BI22, BI23, V1, V2, V3, V4, V5, V6, V7, V8, V9, V10, V11, V12, V13, V14, V15, V16)	----- ----- ---	
Inhibit 51G-2 <i>Selects which inputs inhibit the 51G-2 element</i>	Combination of (BI1, BI2, BI3, BI4, BI5, BI6, BI7, BI8, BI9, BI10, BI11, BI12, BI13, BI14, BI15, BI16, BI17, BI18, BI19, BI20, BI21, BI22, BI23, V1, V2, V3, V4, V5, V6, V7, V8, V9, V10, V11, V12, V13, V14, V15, V16)	----- ----- ---	
Inhibit 51G-3 <i>Selects which inputs inhibit the 51G-3 element</i>	Combination of (BI1, BI2, BI3, BI4, BI5, BI6, BI7, BI8, BI9, BI10, BI11, BI12, BI13, BI14, BI15, BI16, BI17, BI18, BI19, BI20, BI21, BI22, BI23, V1, V2, V3, V4, V5, V6, V7, V8, V9, V10, V11, V12, V13, V14, V15, V16)	----- ----- ---	
Inhibit 51G-4 <i>Selects which inputs inhibit the 51G-4 element</i>	Combination of (BI1, BI2, BI3, BI4, BI5, BI6, BI7, BI8, BI9, BI10, BI11, BI12, BI13, BI14, BI15, BI16, BI17, BI18, BI19, BI20, BI21, BI22, BI23, V1, V2, V3, V4, V5, V6, V7, V8, V9, V10, V11, V12, V13, V14, V15, V16)	----- ----- ---	
Inhibit 50G-1 <i>Selects which inputs inhibit the 50G-1 element</i>	Combination of (BI1, BI2, BI3, BI4, BI5, BI6, BI7, BI8, BI9, BI10, BI11, BI12, BI13, BI14, BI15, BI16, BI17, BI18, BI19, BI20, BI21, BI22, BI23, V1, V2, V3, V4, V5, V6, V7, V8, V9, V10, V11, V12, V13, V14, V15, V16)	----- ----- ---	

Description	Range	Default	Setting
Inhibit 50G-2 <i>Selects which inputs inhibit the 50G-2 element</i>	Combination of (BI1, BI2, BI3, BI4, BI5, BI6, BI7, BI8, BI9, BI10, BI11, BI12, BI13, BI14, BI15, BI16, BI17, BI18, BI19, BI20, BI21, BI22, BI23, V1, V2, V3, V4, V5, V6, V7, V8, V9, V10, V11, V12, V13, V14, V15, V16)	----- ----- ---	
Inhibit 50G-3 <i>Selects which inputs inhibit the 50G-3 element</i>	Combination of (BI1, BI2, BI3, BI4, BI5, BI6, BI7, BI8, BI9, BI10, BI11, BI12, BI13, BI14, BI15, BI16, BI17, BI18, BI19, BI20, BI21, BI22, BI23, V1, V2, V3, V4, V5, V6, V7, V8, V9, V10, V11, V12, V13, V14, V15, V16)	----- ----- ---	
Inhibit 50G-4 <i>Selects which inputs inhibit the 50G-4 element</i>	Combination of (BI1, BI2, BI3, BI4, BI5, BI6, BI7, BI8, BI9, BI10, BI11, BI12, BI13, BI14, BI15, BI16, BI17, BI18, BI19, BI20, BI21, BI22, BI23, V1, V2, V3, V4, V5, V6, V7, V8, V9, V10, V11, V12, V13, V14, V15, V16)	----- ----- ---	
Inhibit 51SEF-1 <i>Selects which inputs inhibit the 51SEF-1 element</i>	Combination of (BI1, BI2, BI3, BI4, BI5, BI6, BI7, BI8, BI9, BI10, BI11, BI12, BI13, BI14, BI15, BI16, BI17, BI18, BI19, BI20, BI21, BI22, BI23, V1, V2, V3, V4, V5, V6, V7, V8, V9, V10, V11, V12, V13, V14, V15, V16)	----- ----- ---	
Inhibit 51SEF-2 <i>Selects which inputs inhibit the 51SEF-2 element</i>	Combination of (BI1, BI2, BI3, BI4, BI5, BI6, BI7, BI8, BI9, BI10, BI11, BI12, BI13, BI14, BI15, BI16, BI17, BI18, BI19, BI20, BI21, BI22, BI23, V1, V2, V3, V4, V5, V6, V7, V8, V9, V10, V11, V12, V13, V14, V15, V16)	----- ----- ---	
Inhibit 51SEF-3 <i>Selects which inputs inhibit the 51SEF-3 element</i>	Combination of (BI1, BI2, BI3, BI4, BI5, BI6, BI7, BI8, BI9, BI10, BI11, BI12, BI13, BI14, BI15, BI16, BI17, BI18, BI19, BI20, BI21, BI22, BI23, V1, V2, V3, V4, V5, V6, V7, V8, V9, V10, V11, V12, V13, V14, V15, V16)	----- ----- ---	
Inhibit 51SEF-4 <i>Selects which inputs inhibit the 51SEF-4 element</i>	Combination of (BI1, BI2, BI3, BI4, BI5, BI6, BI7, BI8, BI9, BI10, BI11, BI12, BI13, BI14, BI15, BI16, BI17, BI18, BI19, BI20, BI21, BI22, BI23, V1, V2, V3, V4, V5, V6, V7, V8, V9, V10, V11, V12, V13, V14, V15, V16)	----- ----- ---	

Description	Range	Default	Setting
Inhibit 50SEF-1 <i>Selects which inputs inhibit the 50SEF-1 element</i>	Combination of (BI1, BI2, BI3, BI4, BI5, BI6, BI7, BI8, BI9, BI10, BI11, BI12, BI13, BI14, BI15, BI16, BI17, BI18, BI19, BI20, BI21, BI22, BI23, V1, V2, V3, V4, V5, V6, V7, V8, V9, V10, V11, V12, V13, V14, V15, V16)	----- ----- ---	
Inhibit 50SEF-2 <i>Selects which inputs inhibit the 50SEF-2 element</i>	Combination of (BI1, BI2, BI3, BI4, BI5, BI6, BI7, BI8, BI9, BI10, BI11, BI12, BI13, BI14, BI15, BI16, BI17, BI18, BI19, BI20, BI21, BI22, BI23, V1, V2, V3, V4, V5, V6, V7, V8, V9, V10, V11, V12, V13, V14, V15, V16)	----- ----- ---	
Inhibit 50SEF-3 <i>Selects which inputs inhibit the 50SEF-3 element</i>	Combination of (BI1, BI2, BI3, BI4, BI5, BI6, BI7, BI8, BI9, BI10, BI11, BI12, BI13, BI14, BI15, BI16, BI17, BI18, BI19, BI20, BI21, BI22, BI23, V1, V2, V3, V4, V5, V6, V7, V8, V9, V10, V11, V12, V13, V14, V15, V16)	----- ----- ---	
Inhibit 50SEF-4 <i>Selects which inputs inhibit the 50SEF-4 element</i>	Combination of (BI1, BI2, BI3, BI4, BI5, BI6, BI7, BI8, BI9, BI10, BI11, BI12, BI13, BI14, BI15, BI16, BI17, BI18, BI19, BI20, BI21, BI22, BI23, V1, V2, V3, V4, V5, V6, V7, V8, V9, V10, V11, V12, V13, V14, V15, V16)	----- ----- ---	
Inhibit 64H <i>Selects which inputs inhibit the 64H element</i>	Combination of (BI1, BI2, BI3, BI4, BI5, BI6, BI7, BI8, BI9, BI10, BI11, BI12, BI13, BI14, BI15, BI16, BI17, BI18, BI19, BI20, BI21, BI22, BI23, V1, V2, V3, V4, V5, V6, V7, V8, V9, V10, V11, V12, V13, V14, V15, V16)	----- ----- ---	
Inhibit 46IT <i>Selects which inputs inhibit the 46IT element</i>	Combination of (BI1, BI2, BI3, BI4, BI5, BI6, BI7, BI8, BI9, BI10, BI11, BI12, BI13, BI14, BI15, BI16, BI17, BI18, BI19, BI20, BI21, BI22, BI23, V1, V2, V3, V4, V5, V6, V7, V8, V9, V10, V11, V12, V13, V14, V15, V16)	----- ----- ---	
Inhibit 46DT <i>Selects which inputs inhibit the 46DT element</i>	Combination of (BI1, BI2, BI3, BI4, BI5, BI6, BI7, BI8, BI9, BI10, BI11, BI12, BI13, BI14, BI15, BI16, BI17, BI18, BI19, BI20, BI21, BI22, BI23, V1, V2, V3, V4, V5, V6, V7, V8, V9, V10, V11, V12, V13, V14, V15, V16)	----- ----- ---	

Description	Range	Default	Setting
Inhibit 37-1 <i>Selects which inputs inhibit the 37-1 element</i>	Combination of (BI1, BI2, BI3, BI4, BI5, BI6, BI7, BI8, BI9, BI10, BI11, BI12, BI13, BI14, BI15, BI16, BI17, BI18, BI19, BI20, BI21, BI22, BI23, V1, V2, V3, V4, V5, V6, V7, V8, V9, V10, V11, V12, V13, V14, V15, V16)	----- ----- ---	
Inhibit 37-2 <i>Selects which inputs inhibit the 37-2 element</i>	Combination of (BI1, BI2, BI3, BI4, BI5, BI6, BI7, BI8, BI9, BI10, BI11, BI12, BI13, BI14, BI15, BI16, BI17, BI18, BI19, BI20, BI21, BI22, BI23, V1, V2, V3, V4, V5, V6, V7, V8, V9, V10, V11, V12, V13, V14, V15, V16)	----- ----- ---	
Inhibit 49 <i>Selects which inputs inhibit the 49 thermal element</i>	Combination of (BI1, BI2, BI3, BI4, BI5, BI6, BI7, BI8, BI9, BI10, BI11, BI12, BI13, BI14, BI15, BI16, BI17, BI18, BI19, BI20, BI21, BI22, BI23, V1, V2, V3, V4, V5, V6, V7, V8, V9, V10, V11, V12, V13, V14, V15, V16)	----- ----- ---	
Reset 49 <i>Selects which inputs resets the 49 thermal model element</i>	Combination of (BI1, BI2, BI3, BI4, BI5, BI6, BI7, BI8, BI9, BI10, BI11, BI12, BI13, BI14, BI15, BI16, BI17, BI18, BI19, BI20, BI21, BI22, BI23, V1, V2, V3, V4, V5, V6, V7, V8, V9, V10, V11, V12, V13, V14, V15, V16)	----- ----- ---	
Inhibit 27/59-1 <i>Selects which inputs inhibit the 27/59-1 element</i>	Combination of (BI1, BI2, BI3, BI4, BI5, BI6, BI7, BI8, BI9, BI10, BI11, BI12, BI13, BI14, BI15, BI16, BI17, BI18, BI19, BI20, BI21, BI22, BI23, V1, V2, V3, V4, V5, V6, V7, V8, V9, V10, V11, V12, V13, V14, V15, V16)	----- ----- ---	
Inhibit 27/59-2 <i>Selects which inputs inhibit the 27/59-2 element</i>	Combination of (BI1, BI2, BI3, BI4, BI5, BI6, BI7, BI8, BI9, BI10, BI11, BI12, BI13, BI14, BI15, BI16, BI17, BI18, BI19, BI20, BI21, BI22, BI23, V1, V2, V3, V4, V5, V6, V7, V8, V9, V10, V11, V12, V13, V14, V15, V16)	----- ----- ---	
Inhibit 27/59-3 <i>Selects which inputs inhibit the 27/59-3 element</i>	Combination of (BI1, BI2, BI3, BI4, BI5, BI6, BI7, BI8, BI9, BI10, BI11, BI12, BI13, BI14, BI15, BI16, BI17, BI18, BI19, BI20, BI21, BI22, BI23, V1, V2, V3, V4, V5, V6, V7, V8, V9, V10, V11, V12, V13, V14, V15, V16)	----- ----- ---	

Description	Range	Default	Setting
Inhibit 27/59-4 <i>Selects which inputs inhibit the 27/59-4 element</i>	Combination of (BI1, BI2, BI3, BI4, BI5, BI6, BI7, BI8, BI9, BI10, BI11, BI12, BI13, BI14, BI15, BI16, BI17, BI18, BI19, BI20, BI21, BI22, BI23, V1, V2, V3, V4, V5, V6, V7, V8, V9, V10, V11, V12, V13, V14, V15, V16)	----- ----- ---	
Inhibit Vx 27/59 <i>Selects which inputs inhibit the Vx 27/59 element</i>	Combination of (BI1, BI2, BI3, BI4, BI5, BI6, BI7, BI8, BI9, BI10, BI11, BI12, BI13, BI14, BI15, BI16, BI17, BI18, BI19, BI20, BI21, BI22, BI23, V1, V2, V3, V4, V5, V6, V7, V8, V9, V10, V11, V12, V13, V14, V15, V16)	----- ----- ---	
Inhibit 47-1 <i>Selects which inputs inhibit the 47-1 element</i>	Combination of (BI1, BI2, BI3, BI4, BI5, BI6, BI7, BI8, BI9, BI10, BI11, BI12, BI13, BI14, BI15, BI16, BI17, BI18, BI19, BI20, BI21, BI22, BI23, V1, V2, V3, V4, V5, V6, V7, V8, V9, V10, V11, V12, V13, V14, V15, V16)	----- ----- ---	
Inhibit 47-2 <i>Selects which inputs inhibit the 47-2 element</i>	Combination of (BI1, BI2, BI3, BI4, BI5, BI6, BI7, BI8, BI9, BI10, BI11, BI12, BI13, BI14, BI15, BI16, BI17, BI18, BI19, BI20, BI21, BI22, BI23, V1, V2, V3, V4, V5, V6, V7, V8, V9, V10, V11, V12, V13, V14, V15, V16)	----- ----- ---	
Inhibit 59NIT <i>Selects which inputs inhibit the 59N IDMTL/DTL element</i>	Combination of (BI1, BI2, BI3, BI4, BI5, BI6, BI7, BI8, BI9, BI10, BI11, BI12, BI13, BI14, BI15, BI16, BI17, BI18, BI19, BI20, BI21, BI22, BI23, V1, V2, V3, V4, V5, V6, V7, V8, V9, V10, V11, V12, V13, V14, V15, V16)	----- ----- ---	
Inhibit 59NDT <i>Selects which inputs inhibit the 59N INST/DTL element</i>	Combination of (BI1, BI2, BI3, BI4, BI5, BI6, BI7, BI8, BI9, BI10, BI11, BI12, BI13, BI14, BI15, BI16, BI17, BI18, BI19, BI20, BI21, BI22, BI23, V1, V2, V3, V4, V5, V6, V7, V8, V9, V10, V11, V12, V13, V14, V15, V16)	----- ----- ---	
Inhibit 81-1 <i>Selects which inputs inhibit the 81-1 element</i>	Combination of (BI1, BI2, BI3, BI4, BI5, BI6, BI7, BI8, BI9, BI10, BI11, BI12, BI13, BI14, BI15, BI16, BI17, BI18, BI19, BI20, BI21, BI22, BI23, V1, V2, V3, V4, V5, V6, V7, V8, V9, V10, V11, V12, V13, V14, V15, V16)	----- ----- ---	

Description	Range	Default	Setting
Inhibit 81-2 <i>Selects which inputs inhibit the 81-2 element</i>	Combination of (BI1, BI2, BI3, BI4, BI5, BI6, BI7, BI8, BI9, BI10, BI11, BI12, BI13, BI14, BI15, BI16, BI17, BI18, BI19, BI20, BI21, BI22, BI23, V1, V2, V3, V4, V5, V6, V7, V8, V9, V10, V11, V12, V13, V14, V15, V16)	----- ----- ---	
Inhibit 81-3 <i>Selects which inputs inhibit the 81-3 element</i>	Combination of (BI1, BI2, BI3, BI4, BI5, BI6, BI7, BI8, BI9, BI10, BI11, BI12, BI13, BI14, BI15, BI16, BI17, BI18, BI19, BI20, BI21, BI22, BI23, V1, V2, V3, V4, V5, V6, V7, V8, V9, V10, V11, V12, V13, V14, V15, V16)	----- ----- ---	
Inhibit 81-4 <i>Selects which inputs inhibit the 81-4 element</i>	Combination of (BI1, BI2, BI3, BI4, BI5, BI6, BI7, BI8, BI9, BI10, BI11, BI12, BI13, BI14, BI15, BI16, BI17, BI18, BI19, BI20, BI21, BI22, BI23, V1, V2, V3, V4, V5, V6, V7, V8, V9, V10, V11, V12, V13, V14, V15, V16)	----- ----- ---	
Inhibit 60CTS <i>Selects which inputs inhibit the CT Supervision element</i>	Combination of (BI1, BI2, BI3, BI4, BI5, BI6, BI7, BI8, BI9, BI10, BI11, BI12, BI13, BI14, BI15, BI16, BI17, BI18, BI19, BI20, BI21, BI22, BI23, V1, V2, V3, V4, V5, V6, V7, V8, V9, V10, V11, V12, V13, V14, V15, V16)	----- ----- ---	
Inhibit 46BC <i>Selects which inputs inhibit the 46 Broken Conductor element</i>	Combination of (BI1, BI2, BI3, BI4, BI5, BI6, BI7, BI8, BI9, BI10, BI11, BI12, BI13, BI14, BI15, BI16, BI17, BI18, BI19, BI20, BI21, BI22, BI23, V1, V2, V3, V4, V5, V6, V7, V8, V9, V10, V11, V12, V13, V14, V15, V16)	----- ----- ---	
74TCS-1 <i>Selects which inputs are monitoring trip circuits</i>	Combination of (BI1, BI2, BI3, BI4, BI5, BI6, BI7, BI8, BI9, BI10, BI11, BI12, BI13, BI14, BI15, BI16, BI17, BI18, BI19, BI20, BI21, BI22, BI23, V1, V2, V3, V4, V5, V6, V7, V8, V9, V10, V11, V12, V13, V14, V15, V16)	----- ----- ---	
74TCS-2 <i>As Above</i>	Combination of (BI1, BI2, BI3, BI4, BI5, BI6, BI7, BI8, BI9, BI10, BI11, BI12, BI13, BI14, BI15, BI16, BI17, BI18, BI19, BI20, BI21, BI22, BI23, V1, V2, V3, V4, V5, V6, V7, V8, V9, V10, V11, V12, V13, V14, V15, V16)	----- ----- ---	

Description	Range	Default	Setting
74TCS-3 <i>As Above</i>	Combination of (BI1, BI2, BI3, BI4, BI5, BI6, BI7, BI8, BI9, BI10, BI11, BI12, BI13, BI14, BI15, BI16, BI17, BI18, BI19, BI20, BI21, BI22, BI23, V1, V2, V3, V4, V5, V6, V7, V8, V9, V10, V11, V12, V13, V14, V15, V16)	----- ----- ---	
Inhibit LOV <i>Selects which inputs inhibit the Loss of Voltage element</i>	Combination of (BI1, BI2, BI3, BI4, BI5, BI6, BI7, BI8, BI9, BI10, BI11, BI12, BI13, BI14, BI15, BI16, BI17, BI18, BI19, BI20, BI21, BI22, BI23, V1, V2, V3, V4, V5, V6, V7, V8, V9, V10, V11, V12, V13, V14, V15, V16)	----- ----- ---	
Trig Trip Contacts <i>Selects which inputs will trigger the Trip contacts</i>	Combination of (BI1, BI2, BI3, BI4, BI5, BI6, BI7, BI8, BI9, BI10, BI11, BI12, BI13, BI14, BI15, BI16, BI17, BI18, BI19, BI20, BI21, BI22, BI23, V1, V2, V3, V4, V5, V6, V7, V8, V9, V10, V11, V12, V13, V14, V15, V16)	----- ----- ---	
Inhibit 50BF <i>Selects which inputs inhibit the 50BF element</i>	Combination of (BI1, BI2, BI3, BI4, BI5, BI6, BI7, BI8, BI9, BI10, BI11, BI12, BI13, BI14, BI15, BI16, BI17, BI18, BI19, BI20, BI21, BI22, BI23, V1, V2, V3, V4, V5, V6, V7, V8, V9, V10, V11, V12, V13, V14, V15, V16)	----- ----- ---	
50BF CB Faulty <i>Selects which input bypasses the 50BF timer due to a fault CB</i>	Combination of (BI1, BI2, BI3, BI4, BI5, BI6, BI7, BI8, BI9, BI10, BI11, BI12, BI13, BI14, BI15, BI16, BI17, BI18, BI19, BI20, BI21, BI22, BI23, V1, V2, V3, V4, V5, V6, V7, V8, V9, V10, V11, V12, V13, V14, V15, V16)	----- ----- ---	
50BF Mech Trip <i>Selects which input allows a mechanical trip to start the 50BF element</i>	Combination of (BI1, BI2, BI3, BI4, BI5, BI6, BI7, BI8, BI9, BI10, BI11, BI12, BI13, BI14, BI15, BI16, BI17, BI18, BI19, BI20, BI21, BI22, BI23, V1, V2, V3, V4, V5, V6, V7, V8, V9, V10, V11, V12, V13, V14, V15, V16)	----- ----- ---	
50BF Ext Trip <i>Selects which inputs can also start the 50BF element</i>	Combination of (BI1, BI2, BI3, BI4, BI5, BI6, BI7, BI8, BI9, BI10, BI11, BI12, BI13, BI14, BI15, BI16, BI17, BI18, BI19, BI20, BI21, BI22, BI23, V1, V2, V3, V4, V5, V6, V7, V8, V9, V10, V11, V12, V13, V14, V15, V16)	----- ----- ---	

Description	Range	Default	Setting
Inhibit 60VTS <i>Selects which inputs inhibit the VT Supervision element</i>	Combination of (BI1, BI2, BI3, BI4, BI5, BI6, BI7, BI8, BI9, BI10, BI11, BI12, BI13, BI14, BI15, BI16, BI17, BI18, BI19, BI20, BI21, BI22, BI23, V1, V2, V3, V4, V5, V6, V7, V8, V9, V10, V11, V12, V13, V14, V15, V16)	----- ----- ---	
Ext Trig 60VTS <i>Selects MCB inputs to VT Supervision element</i>	Combination of (BI1, BI2, BI3, BI4, BI5, BI6, BI7, BI8, BI9, BI10, BI11, BI12, BI13, BI14, BI15, BI16, BI17, BI18, BI19, BI20, BI21, BI22, BI23, V1, V2, V3, V4, V5, V6, V7, V8, V9, V10, V11, V12, V13, V14, V15, V16)	----- ----- ---	
Ext Reset 60VTS <i>Selects which inputs reset the VT Supervision element</i>	Combination of (BI1, BI2, BI3, BI4, BI5, BI6, BI7, BI8, BI9, BI10, BI11, BI12, BI13, BI14, BI15, BI16, BI17, BI18, BI19, BI20, BI21, BI22, BI23, V1, V2, V3, V4, V5, V6, V7, V8, V9, V10, V11, V12, V13, V14, V15, V16)	----- ----- ---	
Inhibit 60VTS-X <i>Selects which inputs inhibit the VT Supervision element on the xyz VTs</i>	Combination of (BI1, BI2, BI3, BI4, BI5, BI6, BI7, BI8, BI9, BI10, BI11, BI12, BI13, BI14, BI15, BI16, BI17, BI18, BI19, BI20, BI21, BI22, BI23, V1, V2, V3, V4, V5, V6, V7, V8, V9, V10, V11, V12, V13, V14, V15, V16)	----- ----- ---	
Ext Trig 60VTS-X <i>Selects MCB inputs to VT Supervision element on the xyz VTs</i>	Combination of (BI1, BI2, BI3, BI4, BI5, BI6, BI7, BI8, BI9, BI10, BI11, BI12, BI13, BI14, BI15, BI16, BI17, BI18, BI19, BI20, BI21, BI22, BI23, V1, V2, V3, V4, V5, V6, V7, V8, V9, V10, V11, V12, V13, V14, V15, V16)	----- ----- ---	
Ext Reset 60VTS-X <i>Selects which inputs reset the VT Supervision element on the xyz VTs</i>	Combination of (BI1, BI2, BI3, BI4, BI5, BI6, BI7, BI8, BI9, BI10, BI11, BI12, BI13, BI14, BI15, BI16, BI17, BI18, BI19, BI20, BI21, BI22, BI23, V1, V2, V3, V4, V5, V6, V7, V8, V9, V10, V11, V12, V13, V14, V15, V16)	----- ----- ---	
Reset CB Total Trip <i>Selects which inputs Reset the CB Total Trip count</i>	Combination of (BI1, BI2, BI3, BI4, BI5, BI6, BI7, BI8, BI9, BI10, BI11, BI12, BI13, BI14, BI15, BI16, BI17, BI18, BI19, BI20, BI21, BI22, BI23, V1, V2, V3, V4, V5, V6, V7, V8, V9, V10, V11, V12, V13, V14, V15, V16)	----- ----- ---	

Description	Range	Default	Setting
Reset CB Delta Trip <i>Selects which inputs Reset the CB Delta Trip count</i>	Combination of (BI1, BI2, BI3, BI4, BI5, BI6, BI7, BI8, BI9, BI10, BI11, BI12, BI13, BI14, BI15, BI16, BI17, BI18, BI19, BI20, BI21, BI22, BI23, V1, V2, V3, V4, V5, V6, V7, V8, V9, V10, V11, V12, V13, V14, V15, V16)	----- ----- ---	
Reset ARBlock Count <i>Selects which inputs Reset the AR Block count</i>	Combination of (BI1, BI2, BI3, BI4, BI5, BI6, BI7, BI8, BI9, BI10, BI11, BI12, BI13, BI14, BI15, BI16, BI17, BI18, BI19, BI20, BI21, BI22, BI23, V1, V2, V3, V4, V5, V6, V7, V8, V9, V10, V11, V12, V13, V14, V15, V16)	----- ----- ---	
Reset Freq Ops Count <i>Selects which inputs Reset the Frequent Ops count</i>	Combination of (BI1, BI2, BI3, BI4, BI5, BI6, BI7, BI8, BI9, BI10, BI11, BI12, BI13, BI14, BI15, BI16, BI17, BI18, BI19, BI20, BI21, BI22, BI23, V1, V2, V3, V4, V5, V6, V7, V8, V9, V10, V11, V12, V13, V14, V15, V16)	----- ----- ---	
Reset CB LO Count <i>Selects which inputs Reset the CB Lockout operations count</i>	Combination of (BI1, BI2, BI3, BI4, BI5, BI6, BI7, BI8, BI9, BI10, BI11, BI12, BI13, BI14, BI15, BI16, BI17, BI18, BI19, BI20, BI21, BI22, BI23, V1, V2, V3, V4, V5, V6, V7, V8, V9, V10, V11, V12, V13, V14, V15, V16)	----- ----- ---	
Reset I ^{2t} CB Wear <i>Selects which inputs Reset the I^{2t} CB Wear element</i>	Combination of (BI1, BI2, BI3, BI4, BI5, BI6, BI7, BI8, BI9, BI10, BI11, BI12, BI13, BI14, BI15, BI16, BI17, BI18, BI19, BI20, BI21, BI22, BI23, V1, V2, V3, V4, V5, V6, V7, V8, V9, V10, V11, V12, V13, V14, V15, V16)	----- ----- ---	
Trigger I ^{2t} CB Wear <i>Selects which inputs will cause an external trigger of the I^{2t} CB Wear element</i>	Combination of (BI1, BI2, BI3, BI4, BI5, BI6, BI7, BI8, BI9, BI10, BI11, BI12, BI13, BI14, BI15, BI16, BI17, BI18, BI19, BI20, BI21, BI22, BI23, V1, V2, V3, V4, V5, V6, V7, V8, V9, V10, V11, V12, V13, V14, V15, V16)	----- ----- ---	
General Alarm 1 <i>Selects which inputs will activate the General Alarm 1 text</i>	Combination of (BI1, BI2, BI3, BI4, BI5, BI6, BI7, BI8, BI9, BI10, BI11, BI12, BI13, BI14, BI15, BI16, BI17, BI18, BI19, BI20, BI21, BI22, BI23, V1, V2, V3, V4, V5, V6, V7, V8, V9, V10, V11, V12, V13, V14, V15, V16)	----- ----- ---	

Description	Range	Default	Setting
General Alarm 2 <i>Selects which inputs will activate the General Alarm 2 text</i>	Combination of (BI1, BI2, BI3, BI4, BI5, BI6, BI7, BI8, BI9, BI10, BI11, BI12, BI13, BI14, BI15, BI16, BI17, BI18, BI19, BI20, BI21, BI22, BI23, V1, V2, V3, V4, V5, V6, V7, V8, V9, V10, V11, V12, V13, V14, V15, V16)	----- ----- ---	
General Alarm 3 <i>Selects which inputs will activate the General Alarm 3 text</i>	Combination of (BI1, BI2, BI3, BI4, BI5, BI6, BI7, BI8, BI9, BI10, BI11, BI12, BI13, BI14, BI15, BI16, BI17, BI18, BI19, BI20, BI21, BI22, BI23, V1, V2, V3, V4, V5, V6, V7, V8, V9, V10, V11, V12, V13, V14, V15, V16)	----- ----- ---	
General Alarm 4 <i>Selects which inputs will activate the General Alarm 4 text</i>	Combination of (BI1, BI2, BI3, BI4, BI5, BI6, BI7, BI8, BI9, BI10, BI11, BI12, BI13, BI14, BI15, BI16, BI17, BI18, BI19, BI20, BI21, BI22, BI23, V1, V2, V3, V4, V5, V6, V7, V8, V9, V10, V11, V12, V13, V14, V15, V16)	----- ----- ---	
General Alarm 5 <i>Selects which inputs will activate the General Alarm 5 text</i>	Combination of (BI1, BI2, BI3, BI4, BI5, BI6, BI7, BI8, BI9, BI10, BI11, BI12, BI13, BI14, BI15, BI16, BI17, BI18, BI19, BI20, BI21, BI22, BI23, V1, V2, V3, V4, V5, V6, V7, V8, V9, V10, V11, V12, V13, V14, V15, V16)	----- ----- ---	
General Alarm 6 <i>Selects which inputs will activate the General Alarm 6 text</i>	Combination of (BI1, BI2, BI3, BI4, BI5, BI6, BI7, BI8, BI9, BI10, BI11, BI12, BI13, BI14, BI15, BI16, BI17, BI18, BI19, BI20, BI21, BI22, BI23, V1, V2, V3, V4, V5, V6, V7, V8, V9, V10, V11, V12, V13, V14, V15, V16)	----- ----- ---	
General Alarm 7 <i>Selects which inputs will activate the General Alarm 7 text</i>	Combination of (BI1, BI2, BI3, BI4, BI5, BI6, BI7, BI8, BI9, BI10, BI11, BI12, BI13, BI14, BI15, BI16, BI17, BI18, BI19, BI20, BI21, BI22, BI23, V1, V2, V3, V4, V5, V6, V7, V8, V9, V10, V11, V12, V13, V14, V15, V16)	----- ----- ---	
General Alarm 8 <i>Selects which inputs will activate the General Alarm 8 text</i>	Combination of (BI1, BI2, BI3, BI4, BI5, BI6, BI7, BI8, BI9, BI10, BI11, BI12, BI13, BI14, BI15, BI16, BI17, BI18, BI19, BI20, BI21, BI22, BI23, V1, V2, V3, V4, V5, V6, V7, V8, V9, V10, V11, V12, V13, V14, V15, V16)	----- ----- ---	

Description	Range	Default	Setting
General Alarm 9 <i>Selects which inputs will activate the General Alarm 9 text</i>	Combination of (BI1, BI2, BI3, BI4, BI5, BI6, BI7, BI8, BI9, BI10, BI11, BI12, BI13, BI14, BI15, BI16, BI17, BI18, BI19, BI20, BI21, BI22, BI23, V1, V2, V3, V4, V5, V6, V7, V8, V9, V10, V11, V12, V13, V14, V15, V16)	----- ----- ---	
General Alarm 10 <i>Selects which inputs will activate the General Alarm 10 text</i>	Combination of (BI1, BI2, BI3, BI4, BI5, BI6, BI7, BI8, BI9, BI10, BI11, BI12, BI13, BI14, BI15, BI16, BI17, BI18, BI19, BI20, BI21, BI22, BI23, V1, V2, V3, V4, V5, V6, V7, V8, V9, V10, V11, V12, V13, V14, V15, V16)	----- ----- ---	
General Alarm 11 <i>Selects which inputs will activate the General Alarm 11 text</i>	Combination of (BI1, BI2, BI3, BI4, BI5, BI6, BI7, BI8, BI9, BI10, BI11, BI12, BI13, BI14, BI15, BI16, BI17, BI18, BI19, BI20, BI21, BI22, BI23, V1, V2, V3, V4, V5, V6, V7, V8, V9, V10, V11, V12, V13, V14, V15, V16)	----- ----- ---	
General Alarm 12 <i>Selects which inputs will activate the General Alarm 12 text</i>	Combination of (BI1, BI2, BI3, BI4, BI5, BI6, BI7, BI8, BI9, BI10, BI11, BI12, BI13, BI14, BI15, BI16, BI17, BI18, BI19, BI20, BI21, BI22, BI23, V1, V2, V3, V4, V5, V6, V7, V8, V9, V10, V11, V12, V13, V14, V15, V16)	----- ----- ---	
BatteryTestRequired <i>Selects which inputs will initiate a Battery test</i>	Combination of (BI1, BI2, BI3, BI4, BI5, BI6, BI7, BI8, BI9, BI10, BI11, BI12, BI13, BI14, BI15, BI16, BI17, BI18, BI19, BI20, BI21, BI22, BI23, V1, V2, V3, V4, V5, V6, V7, V8, V9, V10, V11, V12, V13, V14, V15, V16)	----- ----- ---	
ExtPowerGood <i>Selects which inputs are used to indicate External power to battery is good.</i>	Combination of (BI1, BI2, BI3, BI4, BI5, BI6, BI7, BI8, BI9, BI10, BI11, BI12, BI13, BI14, BI15, BI16, BI17, BI18, BI19, BI20, BI21, BI22, BI23, V1, V2, V3, V4, V5, V6, V7, V8, V9, V10, V11, V12, V13, V14, V15, V16)	----- ----- ---	
InhibitBatteryTest <i>Selects which inputs will inhibit a Battery test.</i>	Combination of (BI1, BI2, BI3, BI4, BI5, BI6, BI7, BI8, BI9, BI10, BI11, BI12, BI13, BI14, BI15, BI16, BI17, BI18, BI19, BI20, BI21, BI22, BI23, V1, V2, V3, V4, V5, V6, V7, V8, V9, V10, V11, V12, V13, V14, V15, V16)	----- ----- ---	

Description	Range	Default	Setting
CapMon Input 1 <i>Selects which inputs will monitor Capacitor level 1.</i>	Combination of (BI1, BI2, BI3, BI4, BI5, BI6, BI7, BI8, BI9, BI10, BI11, BI12, BI13, BI14, BI15, BI16, BI17, BI18, BI19, BI20, BI21, BI22, BI23, V1, V2, V3, V4, V5, V6, V7, V8, V9, V10, V11, V12, V13, V14, V15, V16)	----- ----- ---	
CapMon Input 2 <i>Selects which inputs will monitor Capacitor level 2.</i>	Combination of (BI1, BI2, BI3, BI4, BI5, BI6, BI7, BI8, BI9, BI10, BI11, BI12, BI13, BI14, BI15, BI16, BI17, BI18, BI19, BI20, BI21, BI22, BI23, V1, V2, V3, V4, V5, V6, V7, V8, V9, V10, V11, V12, V13, V14, V15, V16)	----- ----- ---	
Capacitor Test <i>Selects which inputs will initiate a Capacitor test.</i>	Combination of (BI1, BI2, BI3, BI4, BI5, BI6, BI7, BI8, BI9, BI10, BI11, BI12, BI13, BI14, BI15, BI16, BI17, BI18, BI19, BI20, BI21, BI22, BI23, V1, V2, V3, V4, V5, V6, V7, V8, V9, V10, V11, V12, V13, V14, V15, V16)	----- ----- ---	
Inhibit Cap Test <i>Selects which inputs will inhibit a Capacitor test.</i>	Combination of (BI1, BI2, BI3, BI4, BI5, BI6, BI7, BI8, BI9, BI10, BI11, BI12, BI13, BI14, BI15, BI16, BI17, BI18, BI19, BI20, BI21, BI22, BI23, V1, V2, V3, V4, V5, V6, V7, V8, V9, V10, V11, V12, V13, V14, V15, V16)	----- ----- ---	
Reset SagSwell Count <i>Selects which inputs will reset the 27Sag & 59Swell counts.</i>	Combination of (BI1, BI2, BI3, BI4, BI5, BI6, BI7, BI8, BI9, BI10, BI11, BI12, BI13, BI14, BI15, BI16, BI17, BI18, BI19, BI20, BI21, BI22, BI23, V1, V2, V3, V4, V5, V6, V7, V8, V9, V10, V11, V12, V13, V14, V15, V16)	----- ----- ---	
Inhibit 27Sag <i>Selects which inputs will inhibit the 27Sag elements.</i>	Combination of (BI1, BI2, BI3, BI4, BI5, BI6, BI7, BI8, BI9, BI10, BI11, BI12, BI13, BI14, BI15, BI16, BI17, BI18, BI19, BI20, BI21, BI22, BI23, V1, V2, V3, V4, V5, V6, V7, V8, V9, V10, V11, V12, V13, V14, V15, V16)	----- ----- ---	
Inhibit 59Swell <i>Selects which inputs will inhibit the 59Swell elements.</i>	Combination of (BI1, BI2, BI3, BI4, BI5, BI6, BI7, BI8, BI9, BI10, BI11, BI12, BI13, BI14, BI15, BI16, BI17, BI18, BI19, BI20, BI21, BI22, BI23, V1, V2, V3, V4, V5, V6, V7, V8, V9, V10, V11, V12, V13, V14, V15, V16)	----- ----- ---	

Description	Range	Default	Setting
Reset Demand <i>Selects which inputs will reset the Demand elements.</i>	Combination of (BI1, BI2, BI3, BI4, BI5, BI6, BI7, BI8, BI9, BI10, BI11, BI12, BI13, BI14, BI15, BI16, BI17, BI18, BI19, BI20, BI21, BI22, BI23, V1, V2, V3, V4, V5, V6, V7, V8, V9, V10, V11, V12, V13, V14, V15, V16)	----- ----- ---	
Close CB <i>Selects which inputs will issue a close to the circuit breaker.</i>	Combination of (BI1, BI2, BI3, BI4, BI5, BI6, BI7, BI8, BI9, BI10, BI11, BI12, BI13, BI14, BI15, BI16, BI17, BI18, BI19, BI20, BI21, BI22, BI23, V1, V2, V3, V4, V5, V6, V7, V8, V9, V10, V11, V12, V13, V14, V15, V16)	----- ----- ---	
Block Close CB <i>Selects which inputs will block the manual closing of the circuit breaker.</i>	Combination of (BI1, BI2, BI3, BI4, BI5, BI6, BI7, BI8, BI9, BI10, BI11, BI12, BI13, BI14, BI15, BI16, BI17, BI18, BI19, BI20, BI21, BI22, BI23, V1, V2, V3, V4, V5, V6, V7, V8, V9, V10, V11, V12, V13, V14, V15, V16)	----- ----- ---	
Open CB <i>Selects which inputs will issue an open to the circuit breaker.</i>	Combination of (BI1, BI2, BI3, BI4, BI5, BI6, BI7, BI8, BI9, BI10, BI11, BI12, BI13, BI14, BI15, BI16, BI17, BI18, BI19, BI20, BI21, BI22, BI23, V1, V2, V3, V4, V5, V6, V7, V8, V9, V10, V11, V12, V13, V14, V15, V16)	----- ----- ---	
CB Closed <i>Selects which inputs are connected to the circuit breaker closed contacts</i>	Combination of (BI1, BI2, BI3, BI4, BI5, BI6, BI7, BI8, BI9, BI10, BI11, BI12, BI13, BI14, BI15, BI16, BI17, BI18, BI19, BI20, BI21, BI22, BI23, V1, V2, V3, V4, V5, V6, V7, V8, V9, V10, V11, V12, V13, V14, V15, V16)	----- ----- ---	
CB Open <i>Selects which inputs are connected to the circuit breaker open contacts</i>	Combination of (BI1, BI2, BI3, BI4, BI5, BI6, BI7, BI8, BI9, BI10, BI11, BI12, BI13, BI14, BI15, BI16, BI17, BI18, BI19, BI20, BI21, BI22, BI23, V1, V2, V3, V4, V5, V6, V7, V8, V9, V10, V11, V12, V13, V14, V15, V16)	----- ----- ---	
79 Out <i>Selects which inputs will switch the Auto-recloser out of service</i>	Combination of (BI1, BI2, BI3, BI4, BI5, BI6, BI7, BI8, BI9, BI10, BI11, BI12, BI13, BI14, BI15, BI16, BI17, BI18, BI19, BI20, BI21, BI22, BI23, V1, V2, V3, V4, V5, V6, V7, V8, V9, V10, V11, V12, V13, V14, V15, V16)	----- ----- ---	

Description	Range	Default	Setting
79 In <i>Selects which inputs will switch the Auto-recloser in service</i>	Combination of (BI1, BI2, BI3, BI4, BI5, BI6, BI7, BI8, BI9, BI10, BI11, BI12, BI13, BI14, BI15, BI16, BI17, BI18, BI19, BI20, BI21, BI22, BI23, V1, V2, V3, V4, V5, V6, V7, V8, V9, V10, V11, V12, V13, V14, V15, V16)	----- ----- ---	
79 Trip & Reclose <i>Selects which inputs will trigger a trip & reclose</i>	Combination of (BI1, BI2, BI3, BI4, BI5, BI6, BI7, BI8, BI9, BI10, BI11, BI12, BI13, BI14, BI15, BI16, BI17, BI18, BI19, BI20, BI21, BI22, BI23, V1, V2, V3, V4, V5, V6, V7, V8, V9, V10, V11, V12, V13, V14, V15, V16)	----- ----- ---	
79 Trip & Lockout <i>Selects which inputs will trigger a trip & lockout</i>	Combination of (BI1, BI2, BI3, BI4, BI5, BI6, BI7, BI8, BI9, BI10, BI11, BI12, BI13, BI14, BI15, BI16, BI17, BI18, BI19, BI20, BI21, BI22, BI23, V1, V2, V3, V4, V5, V6, V7, V8, V9, V10, V11, V12, V13, V14, V15, V16)	----- ----- ---	
79 Ext Trip <i>Selects which input will start the external an Auto-relay sequence</i>	Combination of (BI1, BI2, BI3, BI4, BI5, BI6, BI7, BI8, BI9, BI10, BI11, BI12, BI13, BI14, BI15, BI16, BI17, BI18, BI19, BI20, BI21, BI22, BI23, V1, V2, V3, V4, V5, V6, V7, V8, V9, V10, V11, V12, V13, V14, V15, V16)	----- ----- ---	
79 Ext Pickup <i>Selects which input should be connected to the pickup of the external elements required to start an Auto-reclose sequence</i>	Combination of (BI1, BI2, BI3, BI4, BI5, BI6, BI7, BI8, BI9, BI10, BI11, BI12, BI13, BI14, BI15, BI16, BI17, BI18, BI19, BI20, BI21, BI22, BI23, V1, V2, V3, V4, V5, V6, V7, V8, V9, V10, V11, V12, V13, V14, V15, V16)	----- ----- ---	
79 Block Reclose <i>Selects which inputs will block the Auto-recloser</i>	Combination of (BI1, BI2, BI3, BI4, BI5, BI6, BI7, BI8, BI9, BI10, BI11, BI12, BI13, BI14, BI15, BI16, BI17, BI18, BI19, BI20, BI21, BI22, BI23, V1, V2, V3, V4, V5, V6, V7, V8, V9, V10, V11, V12, V13, V14, V15, V16)	----- ----- ---	
79 Reset Lockout <i>Selects which inputs will force the Auto-recloser into the Lockout state</i>	Combination of (BI1, BI2, BI3, BI4, BI5, BI6, BI7, BI8, BI9, BI10, BI11, BI12, BI13, BI14, BI15, BI16, BI17, BI18, BI19, BI20, BI21, BI22, BI23, V1, V2, V3, V4, V5, V6, V7, V8, V9, V10, V11, V12, V13, V14, V15, V16)	----- ----- ---	

Description	Range	Default	Setting
79 Line Check <i>Selects which inputs will start the Line Check functionality of the Auto-recloser</i>	Combination of (BI1, BI2, BI3, BI4, BI5, BI6, BI7, BI8, BI9, BI10, BI11, BI12, BI13, BI14, BI15, BI16, BI17, BI18, BI19, BI20, BI21, BI22, BI23, V1, V2, V3, V4, V5, V6, V7, V8, V9, V10, V11, V12, V13, V14, V15, V16)	----- ----- ---	
79 Lockout <i>Selects which inputs will force the Auto-recloser into the Lockout state</i>	Combination of (BI1, BI2, BI3, BI4, BI5, BI6, BI7, BI8, BI9, BI10, BI11, BI12, BI13, BI14, BI15, BI16, BI17, BI18, BI19, BI20, BI21, BI22, BI23, V1, V2, V3, V4, V5, V6, V7, V8, V9, V10, V11, V12, V13, V14, V15, V16)	----- ----- ---	
Hot Line Out <i>Selects which inputs will switch out Hot Line Working</i>	Combination of (BI1, BI2, BI3, BI4, BI5, BI6, BI7, BI8, BI9, BI10, BI11, BI12, BI13, BI14, BI15, BI16, BI17, BI18, BI19, BI20, BI21, BI22, BI23, V1, V2, V3, V4, V5, V6, V7, V8, V9, V10, V11, V12, V13, V14, V15, V16)	----- ----- ---	
Hot Line In <i>Selects which inputs will switch in Hot Line Working</i>	Combination of (BI1, BI2, BI3, BI4, BI5, BI6, BI7, BI8, BI9, BI10, BI11, BI12, BI13, BI14, BI15, BI16, BI17, BI18, BI19, BI20, BI21, BI22, BI23, V1, V2, V3, V4, V5, V6, V7, V8, V9, V10, V11, V12, V13, V14, V15, V16)	----- ----- ---	
Inst Prot'n Out <i>Selects which inputs will switch out the instantaneous protection elements</i>	Combination of (BI1, BI2, BI3, BI4, BI5, BI6, BI7, BI8, BI9, BI10, BI11, BI12, BI13, BI14, BI15, BI16, BI17, BI18, BI19, BI20, BI21, BI22, BI23, V1, V2, V3, V4, V5, V6, V7, V8, V9, V10, V11, V12, V13, V14, V15, V16)	----- ----- ---	
Inst Prot'n In <i>Selects which inputs will switch in the instantaneous protection elements</i>	Combination of (BI1, BI2, BI3, BI4, BI5, BI6, BI7, BI8, BI9, BI10, BI11, BI12, BI13, BI14, BI15, BI16, BI17, BI18, BI19, BI20, BI21, BI22, BI23, V1, V2, V3, V4, V5, V6, V7, V8, V9, V10, V11, V12, V13, V14, V15, V16)	----- ----- ---	
E/F Out <i>Selects which inputs will switch out the E/F protection elements.</i>	Combination of (BI1, BI2, BI3, BI4, BI5, BI6, BI7, BI8, BI9, BI10, BI11, BI12, BI13, BI14, BI15, BI16, BI17, BI18, BI19, BI20, BI21, BI22, BI23, V1, V2, V3, V4, V5, V6, V7, V8, V9, V10, V11, V12, V13, V14, V15, V16)	----- ----- ---	

Description	Range	Default	Setting
E/F In <i>Selects which inputs will switch in the E/F protection elements.</i>	Combination of (BI1, BI2, BI3, BI4, BI5, BI6, BI7, BI8, BI9, BI10, BI11, BI12, BI13, BI14, BI15, BI16, BI17, BI18, BI19, BI20, BI21, BI22, BI23, V1, V2, V3, V4, V5, V6, V7, V8, V9, V10, V11, V12, V13, V14, V15, V16)	----- ----- ---	
SEF Out <i>Selects which inputs will switch out the SEF protection elements</i>	Combination of (BI1, BI2, BI3, BI4, BI5, BI6, BI7, BI8, BI9, BI10, BI11, BI12, BI13, BI14, BI15, BI16, BI17, BI18, BI19, BI20, BI21, BI22, BI23, V1, V2, V3, V4, V5, V6, V7, V8, V9, V10, V11, V12, V13, V14, V15, V16)	----- ----- ---	
SEF In <i>Selects which inputs will switch in the SEF protection elements</i>	Combination of (BI1, BI2, BI3, BI4, BI5, BI6, BI7, BI8, BI9, BI10, BI11, BI12, BI13, BI14, BI15, BI16, BI17, BI18, BI19, BI20, BI21, BI22, BI23, V1, V2, V3, V4, V5, V6, V7, V8, V9, V10, V11, V12, V13, V14, V15, V16)	----- ----- ---	
LOV Out <i>Selects which inputs will switch out the LOV Automation</i>	Combination of (BI1, BI2, BI3, BI4, BI5, BI6, BI7, BI8, BI9, BI10, BI11, BI12, BI13, BI14, BI15, BI16, BI17, BI18, BI19, BI20, BI21, BI22, BI23, V1, V2, V3, V4, V5, V6, V7, V8, V9, V10, V11, V12, V13, V14, V15, V16)	----- ----- ---	
LOV In <i>Selects which inputs will switch in the LOV Automation</i>	Combination of (BI1, BI2, BI3, BI4, BI5, BI6, BI7, BI8, BI9, BI10, BI11, BI12, BI13, BI14, BI15, BI16, BI17, BI18, BI19, BI20, BI21, BI22, BI23, V1, V2, V3, V4, V5, V6, V7, V8, V9, V10, V11, V12, V13, V14, V15, V16)	----- ----- ---	
Trigger Wave Rec <i>Selects which inputs can trigger a waveform record</i>	Combination of (BI1, BI2, BI3, BI4, BI5, BI6, BI7, BI8, BI9, BI10, BI11, BI12, BI13, BI14, BI15, BI16, BI17, BI18, BI19, BI20, BI21, BI22, BI23, V1, V2, V3, V4, V5, V6, V7, V8, V9, V10, V11, V12, V13, V14, V15, V16)	----- ----- ---	
Trigger Fault Rec <i>Selects which inputs can trigger a fault record</i>	Combination of (BI1, BI2, BI3, BI4, BI5, BI6, BI7, BI8, BI9, BI10, BI11, BI12, BI13, BI14, BI15, BI16, BI17, BI18, BI19, BI20, BI21, BI22, BI23, V1, V2, V3, V4, V5, V6, V7, V8, V9, V10, V11, V12, V13, V14, V15, V16)	----- ----- ---	

Description	Range	Default	Setting
Select Group 1 <i>Switches active setting group to group 1</i>	Combination of (BI1, BI2, BI3, BI4, BI5, BI6, BI7, BI8, BI9, BI10, BI11, BI12, BI13, BI14, BI15, BI16, BI17, BI18, BI19, BI20, BI21, BI22, BI23, V1, V2, V3, V4, V5, V6, V7, V8, V9, V10, V11, V12, V13, V14, V15, V16)	----- ----- ---	
Reset Energy Meters	Combination of (BI1, BI2, BI3, BI4, BI5, BI6, BI7, BI8, BI9, BI10, BI11, BI12, BI13, BI14, BI15, BI16, BI17, BI18, BI19, BI20, BI21, BI22, BI23, V1, V2, V3, V4, V5, V6, V7, V8, V9, V10, V11, V12, V13, V14, V15, V16)	----- ----- ---	
Select Group 2 <i>Switches active setting group to group 2</i>	Combination of (BI1, BI2, BI3, BI4, BI5, BI6, BI7, BI8, BI9, BI10, BI11, BI12, BI13, BI14, BI15, BI16, BI17, BI18, BI19, BI20, BI21, BI22, BI23, V1, V2, V3, V4, V5, V6, V7, V8, V9, V10, V11, V12, V13, V14, V15, V16)	----- ----- ---	
Select Group 3 <i>Switches active setting group to group 3</i>	Combination of (BI1, BI2, BI3, BI4, BI5, BI6, BI7, BI8, BI9, BI10, BI11, BI12, BI13, BI14, BI15, BI16, BI17, BI18, BI19, BI20, BI21, BI22, BI23, V1, V2, V3, V4, V5, V6, V7, V8, V9, V10, V11, V12, V13, V14, V15, V16)	----- ----- ---	
Select Group 4 <i>Switches active setting group to group 4</i>	Combination of (BI1, BI2, BI3, BI4, BI5, BI6, BI7, BI8, BI9, BI10, BI11, BI12, BI13, BI14, BI15, BI16, BI17, BI18, BI19, BI20, BI21, BI22, BI23, V1, V2, V3, V4, V5, V6, V7, V8, V9, V10, V11, V12, V13, V14, V15, V16)	----- ----- ---	
Select Group 5 <i>Switches active setting group to group 5</i>	Combination of (BI1, BI2, BI3, BI4, BI5, BI6, BI7, BI8, BI9, BI10, BI11, BI12, BI13, BI14, BI15, BI16, BI17, BI18, BI19, BI20, BI21, BI22, BI23, V1, V2, V3, V4, V5, V6, V7, V8, V9, V10, V11, V12, V13, V14, V15, V16)	----- ----- ---	
Select Group 6 <i>Switches active setting group to group 6</i>	Combination of (BI1, BI2, BI3, BI4, BI5, BI6, BI7, BI8, BI9, BI10, BI11, BI12, BI13, BI14, BI15, BI16, BI17, BI18, BI19, BI20, BI21, BI22, BI23, V1, V2, V3, V4, V5, V6, V7, V8, V9, V10, V11, V12, V13, V14, V15, V16)	----- ----- ---	

Description	Range	Default	Setting
Select Group 7 <i>Switches active setting group to group 7</i>	Combination of (BI1, BI2, BI3, BI4, BI5, BI6, BI7, BI8, BI9, BI10, BI11, BI12, BI13, BI14, BI15, BI16, BI17, BI18, BI19, BI20, BI21, BI22, BI23, V1, V2, V3, V4, V5, V6, V7, V8, V9, V10, V11, V12, V13, V14, V15, V16)	----- ----- ---	
Select Group 8 <i>Switches active setting group to group 8</i>	Combination of (BI1, BI2, BI3, BI4, BI5, BI6, BI7, BI8, BI9, BI10, BI11, BI12, BI13, BI14, BI15, BI16, BI17, BI18, BI19, BI20, BI21, BI22, BI23, V1, V2, V3, V4, V5, V6, V7, V8, V9, V10, V11, V12, V13, V14, V15, V16)	----- ----- ---	
Out Of Service Mode <i>Selects which inputs will put the relay into Out Of Service Mode</i>	Combination of (BI1, BI2, BI3, BI4, BI5, BI6, BI7, BI8, BI9, BI10, BI11, BI12, BI13, BI14, BI15, BI16, BI17, BI18, BI19, BI20, BI21, BI22, BI23, V1, V2, V3, V4, V5, V6, V7, V8, V9, V10, V11, V12, V13, V14, V15, V16)	----- ----- ---	
Local Mode <i>Selects which inputs will put the relay into Local Mode</i>	Combination of (BI1, BI2, BI3, BI4, BI5, BI6, BI7, BI8, BI9, BI10, BI11, BI12, BI13, BI14, BI15, BI16, BI17, BI18, BI19, BI20, BI21, BI22, BI23, V1, V2, V3, V4, V5, V6, V7, V8, V9, V10, V11, V12, V13, V14, V15, V16)	----- ----- ---	
Remote Mode <i>Selects which inputs will put the relay into Remote Mode</i>	Combination of (BI1, BI2, BI3, BI4, BI5, BI6, BI7, BI8, BI9, BI10, BI11, BI12, BI13, BI14, BI15, BI16, BI17, BI18, BI19, BI20, BI21, BI22, BI23, V1, V2, V3, V4, V5, V6, V7, V8, V9, V10, V11, V12, V13, V14, V15, V16)	----- ----- ---	
Local Or Remote Mode <i>Selects which inputs will put the relay into Local Or Remote Mode</i>	Combination of (BI1, BI2, BI3, BI4, BI5, BI6, BI7, BI8, BI9, BI10, BI11, BI12, BI13, BI14, BI15, BI16, BI17, BI18, BI19, BI20, BI21, BI22, BI23, V1, V2, V3, V4, V5, V6, V7, V8, V9, V10, V11, V12, V13, V14, V15, V16)	----- ----- ---	
Clock Sync. <i>Selects which input is used to synchronise the real time clock</i>	Combination of (BI1, BI2, BI3, BI4, BI5, BI6, BI7, BI8, BI9, BI10, BI11, BI12, BI13, BI14, BI15, BI16, BI17, BI18, BI19, BI20, BI21, BI22, BI23, V1, V2, V3, V4, V5, V6, V7, V8, V9, V10, V11, V12, V13, V14, V15, V16)	----- ----- ---	

Description	Range	Default	Setting
Reset LEDs & O/Ps <i>Selects which inputs will reset the latched LEDs and binary outputs</i>	Combination of (BI1, BI2, BI3, BI4, BI5, BI6, BI7, BI8, BI9, BI10, BI11, BI12, BI13, BI14, BI15, BI16, BI17, BI18, BI19, BI20, BI21, BI22, BI23, V1, V2, V3, V4, V5, V6, V7, V8, V9, V10, V11, V12, V13, V14, V15, V16)	----- ----- ---	

4.8.2. Function Key Matrix

Description	Range	Default	Setting
Open CB <i>Selects which function key will Open the circuit breaker</i>	Combination of (1, 2, 3, 4, 5, 6, 7, 8, 9, 10, 11, 12)	-----	
Close CB <i>Selects which function key will Close the circuit breaker</i>	Combination of (1, 2, 3, 4, 5, 6, 7, 8, 9, 10, 11, 12)	-----	
79 In/Out <i>Selects which function key will toggle Autoreclose In & Out</i>	Combination of (1, 2, 3, 4, 5, 6, 7, 8, 9, 10, 11, 12)	-----	
79 Trip & Reclose <i>Selects which function key will cause the CB to trip & reclose</i>	Combination of (1, 2, 3, 4, 5, 6, 7, 8, 9, 10, 11, 12)	-----	
79 Trip & Lockout <i>Selects which function key will cause the CB to trip & lockout</i>	Combination of (1, 2, 3, 4, 5, 6, 7, 8, 9, 10, 11, 12)	-----	
Hot Line Work In/Out <i>Selects which function key will toggle Hot Line Working In & Out</i>	Combination of (1, 2, 3, 4, 5, 6, 7, 8, 9, 10, 11, 12)	-----	
E/F In/Out <i>Selects which function key will toggle E/F protection In & Out</i>	Combination of (1, 2, 3, 4, 5, 6, 7, 8, 9, 10, 11, 12)	-----	
SEF In/Out <i>Selects which function key will toggle SEF protection In & Out</i>	Combination of (1, 2, 3, 4, 5, 6, 7, 8, 9, 10, 11, 12)	-----	
Inst Prot'n In/Out <i>Selects which function key will toggle Instantaneous protection elements In & Out</i>	Combination of (1, 2, 3, 4, 5, 6, 7, 8, 9, 10, 11, 12)	-----	
LOV In/Out <i>Selects which function key will toggle LOV Automation In & Out</i>	Combination of (1, 2, 3, 4, 5, 6, 7, 8, 9, 10, 11, 12)	-----	
Out Of Service Mode	Combination of (1, 2, 3, 4, 5, 6, 7, 8, 9, 10, 11, 12)	-----	
Local Mode	Combination of (1, 2, 3, 4, 5, 6, 7, 8, 9, 10, 11, 12)	-----	
Remote Mode	Combination of (1, 2, 3, 4, 5, 6, 7, 8, 9, 10, 11, 12)	-----	
Local Or Remote Mode <i>Selects which inputs will put the relay into Local Or Remote Mode</i>	Combination of (1, 2, 3, 4, 5, 6, 7, 8, 9, 10, 11, 12)	-----	
BatteryTestRequired <i>Selects which inputs will initiate a Battery test</i>	Combination of (1, 2, 3, 4, 5, 6, 7, 8, 9, 10, 11, 12)	-----	

4.8.3. Binary Input Config

Description	Range	Default	Setting
Inverted Inputs <i>Selects which inputs pickup when voltage is removed.</i>	Combination of (1, 2, 3, 4, 5, 6, 7, 8, 9, 10, 11, 12, 13, 14, 15, 16, 17, 18, 19, 20, 21, 22, 23)	----- ----	
BI 1 Pickup Delay <i>Delay on pickup of DC Binary Input 1</i>	0, 0.005 ... 14300, 14400	0.02s	
BI 1 Dropoff Delay <i>Delay on dropoff of DC Binary Input 1</i>	0, 0.005 ... 14300, 14400	0s	
BI 2 Pickup Delay <i>Delay on pickup of DC Binary Input 2</i>	0, 0.005 ... 14300, 14400	0.02s	
BI 2 Dropoff Delay <i>Delay on dropoff of DC Binary Input 2</i>	0, 0.005 ... 14300, 14400	0s	
BI 3 Pickup Delay <i>Delay on pickup of DC Binary Input 3</i>	0, 0.005 ... 14300, 14400	0.02s	
BI 3 Dropoff Delay <i>Delay on dropoff of DC Binary Input 3</i>	0, 0.005 ... 14300, 14400	0s	
BI 4 Pickup Delay <i>Delay on pickup of DC Binary Input 4</i>	0, 0.005 ... 14300, 14400	0.02s	
BI 4 Dropoff Delay <i>Delay on dropoff of DC Binary Input 4</i>	0, 0.005 ... 14300, 14400	0s	
BI 5 Pickup Delay <i>Delay on pickup of DC Binary Input 5</i>	0, 0.005 ... 14300, 14400	0.02s	
BI 5 Dropoff Delay <i>Delay on dropoff of DC Binary Input 5</i>	0, 0.005 ... 14300, 14400	0s	
BI 6 Pickup Delay <i>Delay on pickup of DC Binary Input 6</i>	0, 0.005 ... 14300, 14400	0.02s	
BI 6 Dropoff Delay <i>Delay on dropoff of DC Binary Input 6</i>	0, 0.005 ... 14300, 14400	0s	
BI 7 Pickup Delay <i>Delay on pickup of DC Binary Input 7</i>	0, 0.005 ... 14300, 14400	0.02s	
BI 7 Dropoff Delay <i>Delay on dropoff of DC Binary Input 7</i>	0, 0.005 ... 14300, 14400	0s	
BI 8 Pickup Delay <i>Delay on pickup of DC Binary Input 8</i>	0, 0.005 ... 14300, 14400	0.02s	
BI 8 Dropoff Delay <i>Delay on dropoff of DC Binary Input 8</i>	0, 0.005 ... 14300, 14400	0s	
BI 9 Pickup Delay <i>Delay on pickup of DC Binary Input 9</i>	0, 0.005 ... 14300, 14400	0.02s	
BI 9 Dropoff Delay <i>Delay on dropoff of DC Binary Input 9</i>	0, 0.005 ... 14300, 14400	0s	
BI 10 Pickup Delay <i>Delay on pickup of DC Binary Input 10</i>	0, 0.005 ... 14300, 14400	0.02s	
BI 10 Dropoff Delay <i>Delay on dropoff of DC Binary Input 10</i>	0, 0.005 ... 14300, 14400	0s	
BI 11 Pickup Delay <i>Delay on pickup of DC Binary Input 11</i>	0, 0.005 ... 14300, 14400	0.02s	

Description	Range	Default	Setting
BI 11 Dropoff Delay <i>Delay on dropoff of DC Binary Input 11</i>	0, 0.005 ... 14300, 14400	0s	
BI 12 Pickup Delay <i>Delay on pickup of DC Binary Input 12</i>	0, 0.005 ... 14300, 14400	0.02s	
BI 12 Dropoff Delay <i>Delay on dropoff of DC Binary Input 12</i>	0, 0.005 ... 14300, 14400	0s	
BI 13 Pickup Delay <i>Delay on pickup of DC Binary Input 13</i>	0, 0.005 ... 14300, 14400	0.02s	
BI 13 Dropoff Delay <i>Delay on dropoff of DC Binary Input 13</i>	0, 0.005 ... 14300, 14400	0s	
BI 14 Pickup Delay <i>Delay on pickup of DC Binary Input 14</i>	0, 0.005 ... 14300, 14400	0.02s	
BI 14 Dropoff Delay <i>Delay on dropoff of DC Binary Input 14</i>	0, 0.005 ... 14300, 14400	0s	
BI 15 Pickup Delay <i>Delay on pickup of DC Binary Input 15</i>	0, 0.005 ... 14300, 14400	0.02s	
BI 15 Dropoff Delay <i>Delay on dropoff of DC Binary Input 15</i>	0, 0.005 ... 14300, 14400	0s	
BI 16 Pickup Delay <i>Delay on pickup of DC Binary Input 16</i>	0, 0.005 ... 14300, 14400	0.02s	
BI 16 Dropoff Delay <i>Delay on dropoff of DC Binary Input 16</i>	0, 0.005 ... 14300, 14400	0s	
BI 17 Pickup Delay <i>Delay on pickup of DC Binary Input 17</i>	0, 0.005 ... 14300, 14400	0.02s	
BI 17 Dropoff Delay <i>Delay on dropoff of DC Binary Input 17</i>	0, 0.005 ... 14300, 14400	0s	
BI 18 Pickup Delay <i>Delay on pickup of DC Binary Input 18</i>	0, 0.005 ... 14300, 14400	0.02s	
BI 18 Dropoff Delay <i>Delay on dropoff of DC Binary Input 18</i>	0, 0.005 ... 14300, 14400	0s	
BI 19 Pickup Delay <i>Delay on pickup of DC Binary Input 19</i>	0, 0.005 ... 14300, 14400	0.02s	
BI 19 Dropoff Delay <i>Delay on dropoff of DC Binary Input 19</i>	0, 0.005 ... 14300, 14400	0s	
BI 20 Pickup Delay <i>Delay on pickup of DC Binary Input 20</i>	0, 0.005 ... 14300, 14400	0.02s	
BI 20 Dropoff Delay <i>Delay on dropoff of DC Binary Input 20</i>	0, 0.005 ... 14300, 14400	0s	
BI 21 Pickup Delay <i>Delay on pickup of DC Binary Input 21</i>	0, 0.005 ... 14300, 14400	0.02s	
BI 21 Dropoff Delay <i>Delay on dropoff of DC Binary Input 21</i>	0, 0.005 ... 14300, 14400	0s	
BI 22 Pickup Delay <i>Delay on pickup of DC Binary Input 22</i>	0, 0.005 ... 14300, 14400	0.02s	
BI 22 Dropoff Delay <i>Delay on dropoff of DC Binary Input 22</i>	0, 0.005 ... 14300, 14400	0s	
BI 23 Pickup Delay <i>Delay on pickup of DC Binary Input 23</i>	0, 0.005 ... 14300, 14400	0.02s	

Description	Range	Default	Setting
BI 23 Dropoff Delay <i>Delay on dropoff of DC Binary Input 23</i>	0, 0.005 ... 14300, 14400	0s	
Enabled In Local <i>Selects which inputs are enabled when the relay is in Operating Mode 'Local' or 'Local Or Remote'</i>	Combination of (1, 2, 3, 4, 5, 6, 7, 8, 9, 10, 11, 12, 13, 14, 15, 16, 17, 18, 19, 20, 21, 22, 23)	1, 2, 3, 4, 5, 6, 7, 8, 9, 10, 11, 12, 13, 14, 15, 16, 17, 18, 19, 20, 21, 22, 23	
Enabled In Remote <i>Selects which inputs are enabled when the relay is in Operating Mode 'Remote' or 'Local Or Remote'</i>	Combination of (1, 2, 3, 4, 5, 6, 7, 8, 9, 10, 11, 12, 13, 14, 15, 16, 17, 18, 19, 20, 21, 22, 23)	1, 2, 3, 4, 5, 6, 7, 8, 9, 10, 11, 12, 13, 14, 15, 16, 17, 18, 19, 20, 21, 22, 23	

4.8.4. Function Key Config

Description	Range	Default	Setting
Function Key 1 Text <i>User definable text that will be used in the HMI function key confirmation screen when Function key 1 is pressed.</i>	(20 Character String)	Function Key 1	
Function Key 2 Text <i>User definable text that will be used in the HMI function key confirmation screen when Function key 2 is pressed.</i>	(20 Character String)	Function Key 2	
Function Key 3 Text <i>User definable text that will be used in the HMI function key confirmation screen when Function key 3 is pressed.</i>	(20 Character String)	Function Key 3	
Function Key 4 Text <i>User definable text that will be used in the HMI function key confirmation screen when Function key 4 is pressed.</i>	(20 Character String)	Function Key 4	
Function Key 5 Text <i>User definable text that will be used in the HMI function key confirmation screen when Function key 5 is pressed.</i>	(20 Character String)	Function Key 5	
Function Key 6 Text <i>User definable text that will be used in the HMI function key confirmation screen when Function key 6 is pressed.</i>	(20 Character String)	Function Key 6	
Function Key 7 Text <i>User definable text that will be used in the HMI function key confirmation screen when Function key 7 is pressed.</i>	(20 Character String)	Function Key 7	
Function Key 8 Text <i>User definable text that will be used in the HMI function key confirmation screen when Function key 8 is pressed.</i>	(20 Character String)	Function Key 8	
Function Key 9 Text <i>User definable text that will be used in the HMI function key confirmation screen when Function key 9 is pressed.</i>	(20 Character String)	Function Key 9	

Description	Range	Default	Setting
Function Key 10 Text <i>User definable text that will be used in the HMI function key confirmation screen when Function key 10 is pressed.</i>	(20 Character String)	Function Key 10	
Function Key 11 Text <i>User definable text that will be used in the HMI function key confirmation screen when Function key 11 is pressed.</i>	(20 Character String)	Function Key 11	
Function Key 12 Text <i>User definable text that will be used in the HMI function key confirmation screen when Function key 12 is pressed.</i>	(20 Character String)	Function Key 12	
Enabled In Remote <i>Selects which inputs are enabled when the relay is in Operating Mode 'Remote' or 'Local Or Remote'</i>	Combination of (1, 2, 3, 4, 5, 6, 7, 8, 9, 10, 11, 12)	----- 1668183366	

4.8.5. General Alarms

Description	Range	Default	Setting
General Alarm-1 <i>Defines the text to be displayed for General Alarm 1</i>	(16 Character String)	ALARM 1	
General Alarm-2 <i>Defines the text to be displayed for General Alarm 2</i>	(16 Character String)	ALARM 2	
General Alarm-3 <i>Defines the text to be displayed for General Alarm 3</i>	(16 Character String)	ALARM 3	
General Alarm-4 <i>Defines the text to be displayed for General Alarm 4</i>	(16 Character String)	ALARM 4	
General Alarm-5 <i>Defines the text to be displayed for General Alarm 5</i>	(16 Character String)	ALARM 5	
General Alarm-6 <i>Defines the text to be displayed for General Alarm 6</i>	(16 Character String)	ALARM 6	
General Alarm-7 <i>Defines the text to be displayed for General Alarm 7</i>	(16 Character String)	ALARM 7	
General Alarm-8 <i>Defines the text to be displayed for General Alarm 8</i>	(16 Character String)	ALARM 8	
General Alarm-9 <i>Defines the text to be displayed for General Alarm 9</i>	(16 Character String)	ALARM 9	
General Alarm-10 <i>Defines the text to be displayed for General Alarm 10</i>	(16 Character String)	ALARM 10	
General Alarm-11 <i>Defines the text to be displayed for General Alarm 11</i>	(16 Character String)	ALARM 11	

Description	Range	Default	Setting
General Alarm-12 <i>Defines the text to be displayed for General Alarm 12</i>	(16 Character String)	ALARM 12	

4.9. Output Config

4.9.1. Output Matrix

Description	Range	Default	Setting
Protection Healthy <i>Relays selected are energised whilst relay self-monitoring does NOT detect any hardware or software errors and DC Supply is healthy. A changeover contact or normally closed contact may be used to generate Protection Defective from this output</i>	Combination of (BO1, BO2, BO3, BO4, BO5, BO6, BO7, BO8, BO9, BO10, BO11, BO12, BO13, BO14, BO15, BO16, BO17, BO18, BO19, BO20, BO21, BO22, L1, L2, L3, L4, L5, L6, L7, L8, L9, L10, L11, L12, L13, L14, L15, L16, L17, L18, L19, L20, V1, V2, V3, V4, V5, V6, V7, V8, V9, V10, V11, V12, V13, V14, V15, V16)	BO1	
51-1 <i>51-1 IDMTL/DTL Overcurrent operated</i>	Combination of (BO1, BO2, BO3, BO4, BO5, BO6, BO7, BO8, BO9, BO10, BO11, BO12, BO13, BO14, BO15, BO16, BO17, BO18, BO19, BO20, BO21, BO22, L1, L2, L3, L4, L5, L6, L7, L8, L9, L10, L11, L12, L13, L14, L15, L16, L17, L18, L19, L20, V1, V2, V3, V4, V5, V6, V7, V8, V9, V10, V11, V12, V13, V14, V15, V16)	----- ----- ----- ----	
51-2 <i>51-2 IDMTL/DTL Overcurrent operated</i>	Combination of (BO1, BO2, BO3, BO4, BO5, BO6, BO7, BO8, BO9, BO10, BO11, BO12, BO13, BO14, BO15, BO16, BO17, BO18, BO19, BO20, BO21, BO22, L1, L2, L3, L4, L5, L6, L7, L8, L9, L10, L11, L12, L13, L14, L15, L16, L17, L18, L19, L20, V1, V2, V3, V4, V5, V6, V7, V8, V9, V10, V11, V12, V13, V14, V15, V16)	----- ----- ----- ----	
51-3 <i>51-3 IDMTL/DTL Overcurrent operated</i>	Combination of (BO1, BO2, BO3, BO4, BO5, BO6, BO7, BO8, BO9, BO10, BO11, BO12, BO13, BO14, BO15, BO16, BO17, BO18, BO19, BO20, BO21, BO22, L1, L2, L3, L4, L5, L6, L7, L8, L9, L10, L11, L12, L13, L14, L15, L16, L17, L18, L19, L20, V1, V2, V3, V4, V5, V6, V7, V8, V9, V10, V11, V12, V13, V14, V15, V16)	----- ----- ----- ----	

Description	Range	Default	Setting
51-4 <i>51-4 IDMTL/DTL Overcurrent operated</i>	Combination of (BO1, BO2, BO3, BO4, BO5, BO6, BO7, BO8, BO9, BO10, BO11, BO12, BO13, BO14, BO15, BO16, BO17, BO18, BO19, BO20, BO21, BO22, L1, L2, L3, L4, L5, L6, L7, L8, L9, L10, L11, L12, L13, L14, L15, L16, L17, L18, L19, L20, V1, V2, V3, V4, V5, V6, V7, V8, V9, V10, V11, V12, V13, V14, V15, V16)	----- ----- ----- ----	
50-1 <i>50-1 INST/DTL Overcurrent operated</i>	Combination of (BO1, BO2, BO3, BO4, BO5, BO6, BO7, BO8, BO9, BO10, BO11, BO12, BO13, BO14, BO15, BO16, BO17, BO18, BO19, BO20, BO21, BO22, L1, L2, L3, L4, L5, L6, L7, L8, L9, L10, L11, L12, L13, L14, L15, L16, L17, L18, L19, L20, V1, V2, V3, V4, V5, V6, V7, V8, V9, V10, V11, V12, V13, V14, V15, V16)	----- ----- ----- ----	
50-2 <i>50-2 INST/DTL Overcurrent operated</i>	Combination of (BO1, BO2, BO3, BO4, BO5, BO6, BO7, BO8, BO9, BO10, BO11, BO12, BO13, BO14, BO15, BO16, BO17, BO18, BO19, BO20, BO21, BO22, L1, L2, L3, L4, L5, L6, L7, L8, L9, L10, L11, L12, L13, L14, L15, L16, L17, L18, L19, L20, V1, V2, V3, V4, V5, V6, V7, V8, V9, V10, V11, V12, V13, V14, V15, V16)	----- ----- ----- ----	
50-3 <i>50-3 INST/DTL Overcurrent operated</i>	Combination of (BO1, BO2, BO3, BO4, BO5, BO6, BO7, BO8, BO9, BO10, BO11, BO12, BO13, BO14, BO15, BO16, BO17, BO18, BO19, BO20, BO21, BO22, L1, L2, L3, L4, L5, L6, L7, L8, L9, L10, L11, L12, L13, L14, L15, L16, L17, L18, L19, L20, V1, V2, V3, V4, V5, V6, V7, V8, V9, V10, V11, V12, V13, V14, V15, V16)	----- ----- ----- ----	
50-4 <i>50-4 INST/DTL Overcurrent operated</i>	Combination of (BO1, BO2, BO3, BO4, BO5, BO6, BO7, BO8, BO9, BO10, BO11, BO12, BO13, BO14, BO15, BO16, BO17, BO18, BO19, BO20, BO21, BO22, L1, L2, L3, L4, L5, L6, L7, L8, L9, L10, L11, L12, L13, L14, L15, L16, L17, L18, L19, L20, V1, V2, V3, V4, V5, V6, V7, V8, V9, V10, V11, V12, V13, V14, V15, V16)	----- ----- ----- ----	

Description	Range	Default	Setting
51G-1 <i>51G-1 IDMTL/DTL measured Earth Fault operated</i>	Combination of (BO1, BO2, BO3, BO4, BO5, BO6, BO7, BO8, BO9, BO10, BO11, BO12, BO13, BO14, BO15, BO16, BO17, BO18, BO19, BO20, BO21, BO22, L1, L2, L3, L4, L5, L6, L7, L8, L9, L10, L11, L12, L13, L14, L15, L16, L17, L18, L19, L20, V1, V2, V3, V4, V5, V6, V7, V8, V9, V10, V11, V12, V13, V14, V15, V16)	L4	
51G-2 <i>51G-2 IDMTL/DTL measured Earth Fault operated</i>	Combination of (BO1, BO2, BO3, BO4, BO5, BO6, BO7, BO8, BO9, BO10, BO11, BO12, BO13, BO14, BO15, BO16, BO17, BO18, BO19, BO20, BO21, BO22, L1, L2, L3, L4, L5, L6, L7, L8, L9, L10, L11, L12, L13, L14, L15, L16, L17, L18, L19, L20, V1, V2, V3, V4, V5, V6, V7, V8, V9, V10, V11, V12, V13, V14, V15, V16)	L4	
51G-3 <i>51G-3 IDMTL/DTL measured Earth Fault operated</i>	Combination of (BO1, BO2, BO3, BO4, BO5, BO6, BO7, BO8, BO9, BO10, BO11, BO12, BO13, BO14, BO15, BO16, BO17, BO18, BO19, BO20, BO21, BO22, L1, L2, L3, L4, L5, L6, L7, L8, L9, L10, L11, L12, L13, L14, L15, L16, L17, L18, L19, L20, V1, V2, V3, V4, V5, V6, V7, V8, V9, V10, V11, V12, V13, V14, V15, V16)	L4	
51G-4 <i>51G-4 IDMTL/DTL measured Earth Fault operated</i>	Combination of (BO1, BO2, BO3, BO4, BO5, BO6, BO7, BO8, BO9, BO10, BO11, BO12, BO13, BO14, BO15, BO16, BO17, BO18, BO19, BO20, BO21, BO22, L1, L2, L3, L4, L5, L6, L7, L8, L9, L10, L11, L12, L13, L14, L15, L16, L17, L18, L19, L20, V1, V2, V3, V4, V5, V6, V7, V8, V9, V10, V11, V12, V13, V14, V15, V16)	L4	
50G-1 <i>50G-1 INST/DTL measured Earth Fault operated</i>	Combination of (BO1, BO2, BO3, BO4, BO5, BO6, BO7, BO8, BO9, BO10, BO11, BO12, BO13, BO14, BO15, BO16, BO17, BO18, BO19, BO20, BO21, BO22, L1, L2, L3, L4, L5, L6, L7, L8, L9, L10, L11, L12, L13, L14, L15, L16, L17, L18, L19, L20, V1, V2, V3, V4, V5, V6, V7, V8, V9, V10, V11, V12, V13, V14, V15, V16)	L4	

Description	Range	Default	Setting
50G-2 <i>50G-2 INST/DTL measured Earth Fault operated</i>	Combination of (BO1, BO2, BO3, BO4, BO5, BO6, BO7, BO8, BO9, BO10, BO11, BO12, BO13, BO14, BO15, BO16, BO17, BO18, BO19, BO20, BO21, BO22, L1, L2, L3, L4, L5, L6, L7, L8, L9, L10, L11, L12, L13, L14, L15, L16, L17, L18, L19, L20, V1, V2, V3, V4, V5, V6, V7, V8, V9, V10, V11, V12, V13, V14, V15, V16)	L4	
50G-3 <i>50G-3 INST/DTL measured Earth Fault operated</i>	Combination of (BO1, BO2, BO3, BO4, BO5, BO6, BO7, BO8, BO9, BO10, BO11, BO12, BO13, BO14, BO15, BO16, BO17, BO18, BO19, BO20, BO21, BO22, L1, L2, L3, L4, L5, L6, L7, L8, L9, L10, L11, L12, L13, L14, L15, L16, L17, L18, L19, L20, V1, V2, V3, V4, V5, V6, V7, V8, V9, V10, V11, V12, V13, V14, V15, V16)	L4	
50G-4 <i>50G-4 INST/DTL measured Earth Fault operated</i>	Combination of (BO1, BO2, BO3, BO4, BO5, BO6, BO7, BO8, BO9, BO10, BO11, BO12, BO13, BO14, BO15, BO16, BO17, BO18, BO19, BO20, BO21, BO22, L1, L2, L3, L4, L5, L6, L7, L8, L9, L10, L11, L12, L13, L14, L15, L16, L17, L18, L19, L20, V1, V2, V3, V4, V5, V6, V7, V8, V9, V10, V11, V12, V13, V14, V15, V16)	L4	
51SEF-1 <i>51SEF-1 IDMTL/DTL Sensitive Earth Fault operated</i>	Combination of (BO1, BO2, BO3, BO4, BO5, BO6, BO7, BO8, BO9, BO10, BO11, BO12, BO13, BO14, BO15, BO16, BO17, BO18, BO19, BO20, BO21, BO22, L1, L2, L3, L4, L5, L6, L7, L8, L9, L10, L11, L12, L13, L14, L15, L16, L17, L18, L19, L20, V1, V2, V3, V4, V5, V6, V7, V8, V9, V10, V11, V12, V13, V14, V15, V16)	L5	
51SEF-2 <i>51SEF-2 IDMTL/DTL Sensitive Earth Fault operated</i>	Combination of (BO1, BO2, BO3, BO4, BO5, BO6, BO7, BO8, BO9, BO10, BO11, BO12, BO13, BO14, BO15, BO16, BO17, BO18, BO19, BO20, BO21, BO22, L1, L2, L3, L4, L5, L6, L7, L8, L9, L10, L11, L12, L13, L14, L15, L16, L17, L18, L19, L20, V1, V2, V3, V4, V5, V6, V7, V8, V9, V10, V11, V12, V13, V14, V15, V16)	L5	

Description	Range	Default	Setting
51SEF-3 <i>51SEF-3 IDMTL/DTL Sensitive Earth Fault operated</i>	Combination of (BO1, BO2, BO3, BO4, BO5, BO6, BO7, BO8, BO9, BO10, BO11, BO12, BO13, BO14, BO15, BO16, BO17, BO18, BO19, BO20, BO21, BO22, L1, L2, L3, L4, L5, L6, L7, L8, L9, L10, L11, L12, L13, L14, L15, L16, L17, L18, L19, L20, V1, V2, V3, V4, V5, V6, V7, V8, V9, V10, V11, V12, V13, V14, V15, V16)	L5	
51SEF-4 <i>51SEF-4 IDMTL/DTL Sensitive Earth Fault operated</i>	Combination of (BO1, BO2, BO3, BO4, BO5, BO6, BO7, BO8, BO9, BO10, BO11, BO12, BO13, BO14, BO15, BO16, BO17, BO18, BO19, BO20, BO21, BO22, L1, L2, L3, L4, L5, L6, L7, L8, L9, L10, L11, L12, L13, L14, L15, L16, L17, L18, L19, L20, V1, V2, V3, V4, V5, V6, V7, V8, V9, V10, V11, V12, V13, V14, V15, V16)	L5	
50SEF-1 <i>50SEF-1 INST/DTL Sensitive Earth Fault operated</i>	Combination of (BO1, BO2, BO3, BO4, BO5, BO6, BO7, BO8, BO9, BO10, BO11, BO12, BO13, BO14, BO15, BO16, BO17, BO18, BO19, BO20, BO21, BO22, L1, L2, L3, L4, L5, L6, L7, L8, L9, L10, L11, L12, L13, L14, L15, L16, L17, L18, L19, L20, V1, V2, V3, V4, V5, V6, V7, V8, V9, V10, V11, V12, V13, V14, V15, V16)	L5	
50SEF-2 <i>50SEF-2 INST/DTL Sensitive Earth Fault operated</i>	Combination of (BO1, BO2, BO3, BO4, BO5, BO6, BO7, BO8, BO9, BO10, BO11, BO12, BO13, BO14, BO15, BO16, BO17, BO18, BO19, BO20, BO21, BO22, L1, L2, L3, L4, L5, L6, L7, L8, L9, L10, L11, L12, L13, L14, L15, L16, L17, L18, L19, L20, V1, V2, V3, V4, V5, V6, V7, V8, V9, V10, V11, V12, V13, V14, V15, V16)	L5	
50SEF-3 <i>50SEF-3 INST/DTL Sensitive Earth Fault operated</i>	Combination of (BO1, BO2, BO3, BO4, BO5, BO6, BO7, BO8, BO9, BO10, BO11, BO12, BO13, BO14, BO15, BO16, BO17, BO18, BO19, BO20, BO21, BO22, L1, L2, L3, L4, L5, L6, L7, L8, L9, L10, L11, L12, L13, L14, L15, L16, L17, L18, L19, L20, V1, V2, V3, V4, V5, V6, V7, V8, V9, V10, V11, V12, V13, V14, V15, V16)	L5	

Description	Range	Default	Setting
50SEF-4 <i>50SEF-4 INST/DTL Sensitive Earth Fault operated</i>	Combination of (BO1, BO2, BO3, BO4, BO5, BO6, BO7, BO8, BO9, BO10, BO11, BO12, BO13, BO14, BO15, BO16, BO17, BO18, BO19, BO20, BO21, BO22, L1, L2, L3, L4, L5, L6, L7, L8, L9, L10, L11, L12, L13, L14, L15, L16, L17, L18, L19, L20, V1, V2, V3, V4, V5, V6, V7, V8, V9, V10, V11, V12, V13, V14, V15, V16)	L5	
64H <i>64H Restricted Earth Fault element operated</i>	Combination of (BO1, BO2, BO3, BO4, BO5, BO6, BO7, BO8, BO9, BO10, BO11, BO12, BO13, BO14, BO15, BO16, BO17, BO18, BO19, BO20, BO21, BO22, L1, L2, L3, L4, L5, L6, L7, L8, L9, L10, L11, L12, L13, L14, L15, L16, L17, L18, L19, L20, V1, V2, V3, V4, V5, V6, V7, V8, V9, V10, V11, V12, V13, V14, V15, V16)	----- ----- ----- ----	
Cold Load Active <i>Cold Load settings are active</i>	Combination of (BO1, BO2, BO3, BO4, BO5, BO6, BO7, BO8, BO9, BO10, BO11, BO12, BO13, BO14, BO15, BO16, BO17, BO18, BO19, BO20, BO21, BO22, L1, L2, L3, L4, L5, L6, L7, L8, L9, L10, L11, L12, L13, L14, L15, L16, L17, L18, L19, L20, V1, V2, V3, V4, V5, V6, V7, V8, V9, V10, V11, V12, V13, V14, V15, V16)	----- ----- ----- ----	
46IT <i>IDMTL/DTL NPS Overcurrent operated</i>	Combination of (BO1, BO2, BO3, BO4, BO5, BO6, BO7, BO8, BO9, BO10, BO11, BO12, BO13, BO14, BO15, BO16, BO17, BO18, BO19, BO20, BO21, BO22, L1, L2, L3, L4, L5, L6, L7, L8, L9, L10, L11, L12, L13, L14, L15, L16, L17, L18, L19, L20, V1, V2, V3, V4, V5, V6, V7, V8, V9, V10, V11, V12, V13, V14, V15, V16)	----- ----- ----- ----	
46DT <i>INST/DTL NPS Overcurrent operated</i>	Combination of (BO1, BO2, BO3, BO4, BO5, BO6, BO7, BO8, BO9, BO10, BO11, BO12, BO13, BO14, BO15, BO16, BO17, BO18, BO19, BO20, BO21, BO22, L1, L2, L3, L4, L5, L6, L7, L8, L9, L10, L11, L12, L13, L14, L15, L16, L17, L18, L19, L20, V1, V2, V3, V4, V5, V6, V7, V8, V9, V10, V11, V12, V13, V14, V15, V16)	----- ----- ----- ----	

Description	Range	Default	Setting
37-1 <i>37-1 Under Current operated</i>	Combination of (BO1, BO2, BO3, BO4, BO5, BO6, BO7, BO8, BO9, BO10, BO11, BO12, BO13, BO14, BO15, BO16, BO17, BO18, BO19, BO20, BO21, BO22, L1, L2, L3, L4, L5, L6, L7, L8, L9, L10, L11, L12, L13, L14, L15, L16, L17, L18, L19, L20, V1, V2, V3, V4, V5, V6, V7, V8, V9, V10, V11, V12, V13, V14, V15, V16)	----- ----- ----- ----	
37-2 <i>37-2 Under Current operated</i>	Combination of (BO1, BO2, BO3, BO4, BO5, BO6, BO7, BO8, BO9, BO10, BO11, BO12, BO13, BO14, BO15, BO16, BO17, BO18, BO19, BO20, BO21, BO22, L1, L2, L3, L4, L5, L6, L7, L8, L9, L10, L11, L12, L13, L14, L15, L16, L17, L18, L19, L20, V1, V2, V3, V4, V5, V6, V7, V8, V9, V10, V11, V12, V13, V14, V15, V16)	----- ----- ----- ----	
49 Trip <i>Thermal capacity trip operated</i>	Combination of (BO1, BO2, BO3, BO4, BO5, BO6, BO7, BO8, BO9, BO10, BO11, BO12, BO13, BO14, BO15, BO16, BO17, BO18, BO19, BO20, BO21, BO22, L1, L2, L3, L4, L5, L6, L7, L8, L9, L10, L11, L12, L13, L14, L15, L16, L17, L18, L19, L20, V1, V2, V3, V4, V5, V6, V7, V8, V9, V10, V11, V12, V13, V14, V15, V16)	----- ----- ----- ----	
49 Alarm <i>Thermal capacity alarm operated</i>	Combination of (BO1, BO2, BO3, BO4, BO5, BO6, BO7, BO8, BO9, BO10, BO11, BO12, BO13, BO14, BO15, BO16, BO17, BO18, BO19, BO20, BO21, BO22, L1, L2, L3, L4, L5, L6, L7, L8, L9, L10, L11, L12, L13, L14, L15, L16, L17, L18, L19, L20, V1, V2, V3, V4, V5, V6, V7, V8, V9, V10, V11, V12, V13, V14, V15, V16)	----- ----- ----- ----	
27/59-1 <i>Under/Overtension stage 1 operated</i>	Combination of (BO1, BO2, BO3, BO4, BO5, BO6, BO7, BO8, BO9, BO10, BO11, BO12, BO13, BO14, BO15, BO16, BO17, BO18, BO19, BO20, BO21, BO22, L1, L2, L3, L4, L5, L6, L7, L8, L9, L10, L11, L12, L13, L14, L15, L16, L17, L18, L19, L20, V1, V2, V3, V4, V5, V6, V7, V8, V9, V10, V11, V12, V13, V14, V15, V16)	----- ----- ----- ----	

Description	Range	Default	Setting
27/59-2 <i>Under/Overtension stage 2 operated</i>	Combination of (BO1, BO2, BO3, BO4, BO5, BO6, BO7, BO8, BO9, BO10, BO11, BO12, BO13, BO14, BO15, BO16, BO17, BO18, BO19, BO20, BO21, BO22, L1, L2, L3, L4, L5, L6, L7, L8, L9, L10, L11, L12, L13, L14, L15, L16, L17, L18, L19, L20, V1, V2, V3, V4, V5, V6, V7, V8, V9, V10, V11, V12, V13, V14, V15, V16)	----- ----- ----- ----	
27/59-3 <i>Under/Overtension stage 3 operated</i>	Combination of (BO1, BO2, BO3, BO4, BO5, BO6, BO7, BO8, BO9, BO10, BO11, BO12, BO13, BO14, BO15, BO16, BO17, BO18, BO19, BO20, BO21, BO22, L1, L2, L3, L4, L5, L6, L7, L8, L9, L10, L11, L12, L13, L14, L15, L16, L17, L18, L19, L20, V1, V2, V3, V4, V5, V6, V7, V8, V9, V10, V11, V12, V13, V14, V15, V16)	----- ----- ----- ----	
27/59-4 <i>Under/Overtension stage 4 operated</i>	Combination of (BO1, BO2, BO3, BO4, BO5, BO6, BO7, BO8, BO9, BO10, BO11, BO12, BO13, BO14, BO15, BO16, BO17, BO18, BO19, BO20, BO21, BO22, L1, L2, L3, L4, L5, L6, L7, L8, L9, L10, L11, L12, L13, L14, L15, L16, L17, L18, L19, L20, V1, V2, V3, V4, V5, V6, V7, V8, V9, V10, V11, V12, V13, V14, V15, V16)	----- ----- ----- ----	
Vx 27/59 <i>Under/Overtension Vx stage operated</i>	Combination of (BO1, BO2, BO3, BO4, BO5, BO6, BO7, BO8, BO9, BO10, BO11, BO12, BO13, BO14, BO15, BO16, BO17, BO18, BO19, BO20, BO21, BO22, L1, L2, L3, L4, L5, L6, L7, L8, L9, L10, L11, L12, L13, L14, L15, L16, L17, L18, L19, L20, V1, V2, V3, V4, V5, V6, V7, V8, V9, V10, V11, V12, V13, V14, V15, V16)	----- ----- ----- ----	
47-1 <i>INST/DTL NPS Overtension stage 1 operated</i>	Combination of (BO1, BO2, BO3, BO4, BO5, BO6, BO7, BO8, BO9, BO10, BO11, BO12, BO13, BO14, BO15, BO16, BO17, BO18, BO19, BO20, BO21, BO22, L1, L2, L3, L4, L5, L6, L7, L8, L9, L10, L11, L12, L13, L14, L15, L16, L17, L18, L19, L20, V1, V2, V3, V4, V5, V6, V7, V8, V9, V10, V11, V12, V13, V14, V15, V16)	----- ----- ----- ----	

Description	Range	Default	Setting
47-2 <i>INST/DTL NPS Overvoltage stage 2 operated</i>	Combination of (BO1, BO2, BO3, BO4, BO5, BO6, BO7, BO8, BO9, BO10, BO11, BO12, BO13, BO14, BO15, BO16, BO17, BO18, BO19, BO20, BO21, BO22, L1, L2, L3, L4, L5, L6, L7, L8, L9, L10, L11, L12, L13, L14, L15, L16, L17, L18, L19, L20, V1, V2, V3, V4, V5, V6, V7, V8, V9, V10, V11, V12, V13, V14, V15, V16)	----- ----- ----- ----	
59NIT <i>Neutral Overvoltage IDMTL/DTL operated</i>	Combination of (BO1, BO2, BO3, BO4, BO5, BO6, BO7, BO8, BO9, BO10, BO11, BO12, BO13, BO14, BO15, BO16, BO17, BO18, BO19, BO20, BO21, BO22, L1, L2, L3, L4, L5, L6, L7, L8, L9, L10, L11, L12, L13, L14, L15, L16, L17, L18, L19, L20, V1, V2, V3, V4, V5, V6, V7, V8, V9, V10, V11, V12, V13, V14, V15, V16)	----- ----- ----- ----	
59NDT <i>Neutral Overvoltage INST/DTL operated</i>	Combination of (BO1, BO2, BO3, BO4, BO5, BO6, BO7, BO8, BO9, BO10, BO11, BO12, BO13, BO14, BO15, BO16, BO17, BO18, BO19, BO20, BO21, BO22, L1, L2, L3, L4, L5, L6, L7, L8, L9, L10, L11, L12, L13, L14, L15, L16, L17, L18, L19, L20, V1, V2, V3, V4, V5, V6, V7, V8, V9, V10, V11, V12, V13, V14, V15, V16)	----- ----- ----- ----	
81-1 <i>Under/Over frequency stage 1 operated</i>	Combination of (BO1, BO2, BO3, BO4, BO5, BO6, BO7, BO8, BO9, BO10, BO11, BO12, BO13, BO14, BO15, BO16, BO17, BO18, BO19, BO20, BO21, BO22, L1, L2, L3, L4, L5, L6, L7, L8, L9, L10, L11, L12, L13, L14, L15, L16, L17, L18, L19, L20, V1, V2, V3, V4, V5, V6, V7, V8, V9, V10, V11, V12, V13, V14, V15, V16)	----- ----- ----- ----	
81-2 <i>Under/Over frequency stage 2 operated</i>	Combination of (BO1, BO2, BO3, BO4, BO5, BO6, BO7, BO8, BO9, BO10, BO11, BO12, BO13, BO14, BO15, BO16, BO17, BO18, BO19, BO20, BO21, BO22, L1, L2, L3, L4, L5, L6, L7, L8, L9, L10, L11, L12, L13, L14, L15, L16, L17, L18, L19, L20, V1, V2, V3, V4, V5, V6, V7, V8, V9, V10, V11, V12, V13, V14, V15, V16)	----- ----- ----- ----	

Description	Range	Default	Setting
81-3 <i>Under/Over frequency stage 3 operated</i>	Combination of (BO1, BO2, BO3, BO4, BO5, BO6, BO7, BO8, BO9, BO10, BO11, BO12, BO13, BO14, BO15, BO16, BO17, BO18, BO19, BO20, BO21, BO22, L1, L2, L3, L4, L5, L6, L7, L8, L9, L10, L11, L12, L13, L14, L15, L16, L17, L18, L19, L20, V1, V2, V3, V4, V5, V6, V7, V8, V9, V10, V11, V12, V13, V14, V15, V16)	----- ----- ----- ----	
81-4 <i>Under/Over frequency stage 4 operated</i>	Combination of (BO1, BO2, BO3, BO4, BO5, BO6, BO7, BO8, BO9, BO10, BO11, BO12, BO13, BO14, BO15, BO16, BO17, BO18, BO19, BO20, BO21, BO22, L1, L2, L3, L4, L5, L6, L7, L8, L9, L10, L11, L12, L13, L14, L15, L16, L17, L18, L19, L20, V1, V2, V3, V4, V5, V6, V7, V8, V9, V10, V11, V12, V13, V14, V15, V16)	----- ----- ----- ----	
60CTS <i>CT Supervision element operated</i>	Combination of (BO1, BO2, BO3, BO4, BO5, BO6, BO7, BO8, BO9, BO10, BO11, BO12, BO13, BO14, BO15, BO16, BO17, BO18, BO19, BO20, BO21, BO22, L1, L2, L3, L4, L5, L6, L7, L8, L9, L10, L11, L12, L13, L14, L15, L16, L17, L18, L19, L20, V1, V2, V3, V4, V5, V6, V7, V8, V9, V10, V11, V12, V13, V14, V15, V16)	----- ----- ----- ----	
46BC <i>46 Broken Conductor element operated</i>	Combination of (BO1, BO2, BO3, BO4, BO5, BO6, BO7, BO8, BO9, BO10, BO11, BO12, BO13, BO14, BO15, BO16, BO17, BO18, BO19, BO20, BO21, BO22, L1, L2, L3, L4, L5, L6, L7, L8, L9, L10, L11, L12, L13, L14, L15, L16, L17, L18, L19, L20, V1, V2, V3, V4, V5, V6, V7, V8, V9, V10, V11, V12, V13, V14, V15, V16)	----- ----- ----- ----	
74TCS-1 <i>Trip Circuit 1 fail operated</i>	Combination of (BO1, BO2, BO3, BO4, BO5, BO6, BO7, BO8, BO9, BO10, BO11, BO12, BO13, BO14, BO15, BO16, BO17, BO18, BO19, BO20, BO21, BO22, L1, L2, L3, L4, L5, L6, L7, L8, L9, L10, L11, L12, L13, L14, L15, L16, L17, L18, L19, L20, V1, V2, V3, V4, V5, V6, V7, V8, V9, V10, V11, V12, V13, V14, V15, V16)	----- ----- ----- ----	

Description	Range	Default	Setting
74TCS-2 <i>Trip Circuit 2 fail operated</i>	Combination of (BO1, BO2, BO3, BO4, BO5, BO6, BO7, BO8, BO9, BO10, BO11, BO12, BO13, BO14, BO15, BO16, BO17, BO18, BO19, BO20, BO21, BO22, L1, L2, L3, L4, L5, L6, L7, L8, L9, L10, L11, L12, L13, L14, L15, L16, L17, L18, L19, L20, V1, V2, V3, V4, V5, V6, V7, V8, V9, V10, V11, V12, V13, V14, V15, V16)	----- ----- ----- ----	
74TCS-3 <i>Trip Circuit 3 fail operated</i>	Combination of (BO1, BO2, BO3, BO4, BO5, BO6, BO7, BO8, BO9, BO10, BO11, BO12, BO13, BO14, BO15, BO16, BO17, BO18, BO19, BO20, BO21, BO22, L1, L2, L3, L4, L5, L6, L7, L8, L9, L10, L11, L12, L13, L14, L15, L16, L17, L18, L19, L20, V1, V2, V3, V4, V5, V6, V7, V8, V9, V10, V11, V12, V13, V14, V15, V16)	----- ----- ----- ----	
General Pickup <i>General Pickup operated</i>	Combination of (BO1, BO2, BO3, BO4, BO5, BO6, BO7, BO8, BO9, BO10, BO11, BO12, BO13, BO14, BO15, BO16, BO17, BO18, BO19, BO20, BO21, BO22, L1, L2, L3, L4, L5, L6, L7, L8, L9, L10, L11, L12, L13, L14, L15, L16, L17, L18, L19, L20, V1, V2, V3, V4, V5, V6, V7, V8, V9, V10, V11, V12, V13, V14, V15, V16)	----- ----- ----- ----	
LOV ABC Live <i>Phase A or Phase B or Phase C is classed as being Live</i>	Combination of (BO1, BO2, BO3, BO4, BO5, BO6, BO7, BO8, BO9, BO10, BO11, BO12, BO13, BO14, BO15, BO16, BO17, BO18, BO19, BO20, BO21, BO22, L1, L2, L3, L4, L5, L6, L7, L8, L9, L10, L11, L12, L13, L14, L15, L16, L17, L18, L19, L20, V1, V2, V3, V4, V5, V6, V7, V8, V9, V10, V11, V12, V13, V14, V15, V16)	----- ----- ----- ----	
LOV XYZ Live <i>Phase X or Phase Y or Phase Z is classed as being Live</i>	Combination of (BO1, BO2, BO3, BO4, BO5, BO6, BO7, BO8, BO9, BO10, BO11, BO12, BO13, BO14, BO15, BO16, BO17, BO18, BO19, BO20, BO21, BO22, L1, L2, L3, L4, L5, L6, L7, L8, L9, L10, L11, L12, L13, L14, L15, L16, L17, L18, L19, L20, V1, V2, V3, V4, V5, V6, V7, V8, V9, V10, V11, V12, V13, V14, V15, V16)	----- ----- ----- ----	

Description	Range	Default	Setting
LOV A Live <i>Phase A is classed as being Live</i>	Combination of (BO1, BO2, BO3, BO4, BO5, BO6, BO7, BO8, BO9, BO10, BO11, BO12, BO13, BO14, BO15, BO16, BO17, BO18, BO19, BO20, BO21, BO22, L1, L2, L3, L4, L5, L6, L7, L8, L9, L10, L11, L12, L13, L14, L15, L16, L17, L18, L19, L20, V1, V2, V3, V4, V5, V6, V7, V8, V9, V10, V11, V12, V13, V14, V15, V16)	----- ----- ----- ----	
LOV B Live <i>Phase B is classed as being Live</i>	Combination of (BO1, BO2, BO3, BO4, BO5, BO6, BO7, BO8, BO9, BO10, BO11, BO12, BO13, BO14, BO15, BO16, BO17, BO18, BO19, BO20, BO21, BO22, L1, L2, L3, L4, L5, L6, L7, L8, L9, L10, L11, L12, L13, L14, L15, L16, L17, L18, L19, L20, V1, V2, V3, V4, V5, V6, V7, V8, V9, V10, V11, V12, V13, V14, V15, V16)	----- ----- ----- ----	
LOV C Live <i>Phase C is classed as being Live</i>	Combination of (BO1, BO2, BO3, BO4, BO5, BO6, BO7, BO8, BO9, BO10, BO11, BO12, BO13, BO14, BO15, BO16, BO17, BO18, BO19, BO20, BO21, BO22, L1, L2, L3, L4, L5, L6, L7, L8, L9, L10, L11, L12, L13, L14, L15, L16, L17, L18, L19, L20, V1, V2, V3, V4, V5, V6, V7, V8, V9, V10, V11, V12, V13, V14, V15, V16)	----- ----- ----- ----	
LOV X Live <i>Phase X is classed as being Live</i>	Combination of (BO1, BO2, BO3, BO4, BO5, BO6, BO7, BO8, BO9, BO10, BO11, BO12, BO13, BO14, BO15, BO16, BO17, BO18, BO19, BO20, BO21, BO22, L1, L2, L3, L4, L5, L6, L7, L8, L9, L10, L11, L12, L13, L14, L15, L16, L17, L18, L19, L20, V1, V2, V3, V4, V5, V6, V7, V8, V9, V10, V11, V12, V13, V14, V15, V16)	----- ----- ----- ----	
LOV Y Live <i>Phase Y is classed as being Live</i>	Combination of (BO1, BO2, BO3, BO4, BO5, BO6, BO7, BO8, BO9, BO10, BO11, BO12, BO13, BO14, BO15, BO16, BO17, BO18, BO19, BO20, BO21, BO22, L1, L2, L3, L4, L5, L6, L7, L8, L9, L10, L11, L12, L13, L14, L15, L16, L17, L18, L19, L20, V1, V2, V3, V4, V5, V6, V7, V8, V9, V10, V11, V12, V13, V14, V15, V16)	----- ----- ----- ----	

Description	Range	Default	Setting
LOV Z Live <i>Phase Z is classed as being Live</i>	Combination of (BO1, BO2, BO3, BO4, BO5, BO6, BO7, BO8, BO9, BO10, BO11, BO12, BO13, BO14, BO15, BO16, BO17, BO18, BO19, BO20, BO21, BO22, L1, L2, L3, L4, L5, L6, L7, L8, L9, L10, L11, L12, L13, L14, L15, L16, L17, L18, L19, L20, V1, V2, V3, V4, V5, V6, V7, V8, V9, V10, V11, V12, V13, V14, V15, V16)	----- ----- ----- ----	
LOV Primed <i>The prime conditions have been met and Loss Of Voltage Automation will start when the voltage is lost.</i>	Combination of (BO1, BO2, BO3, BO4, BO5, BO6, BO7, BO8, BO9, BO10, BO11, BO12, BO13, BO14, BO15, BO16, BO17, BO18, BO19, BO20, BO21, BO22, L1, L2, L3, L4, L5, L6, L7, L8, L9, L10, L11, L12, L13, L14, L15, L16, L17, L18, L19, L20, V1, V2, V3, V4, V5, V6, V7, V8, V9, V10, V11, V12, V13, V14, V15, V16)	----- ----- ----- ----	
LOV In Progress <i>Loss Of Voltage Automation is in progress.</i>	Combination of (BO1, BO2, BO3, BO4, BO5, BO6, BO7, BO8, BO9, BO10, BO11, BO12, BO13, BO14, BO15, BO16, BO17, BO18, BO19, BO20, BO21, BO22, L1, L2, L3, L4, L5, L6, L7, L8, L9, L10, L11, L12, L13, L14, L15, L16, L17, L18, L19, L20, V1, V2, V3, V4, V5, V6, V7, V8, V9, V10, V11, V12, V13, V14, V15, V16)	----- ----- ----- ----	
LOV Fail <i>Loss Of Voltage Automation did not complete successfully.</i>	Combination of (BO1, BO2, BO3, BO4, BO5, BO6, BO7, BO8, BO9, BO10, BO11, BO12, BO13, BO14, BO15, BO16, BO17, BO18, BO19, BO20, BO21, BO22, L1, L2, L3, L4, L5, L6, L7, L8, L9, L10, L11, L12, L13, L14, L15, L16, L17, L18, L19, L20, V1, V2, V3, V4, V5, V6, V7, V8, V9, V10, V11, V12, V13, V14, V15, V16)	----- ----- ----- ----	
LOV A <i>Loss Of Voltage Automation has been performed and Phase A was involved.</i>	Combination of (BO1, BO2, BO3, BO4, BO5, BO6, BO7, BO8, BO9, BO10, BO11, BO12, BO13, BO14, BO15, BO16, BO17, BO18, BO19, BO20, BO21, BO22, L1, L2, L3, L4, L5, L6, L7, L8, L9, L10, L11, L12, L13, L14, L15, L16, L17, L18, L19, L20, V1, V2, V3, V4, V5, V6, V7, V8, V9, V10, V11, V12, V13, V14, V15, V16)	----- ----- ----- ----	

Description	Range	Default	Setting
LOV X <i>Loss Of Voltage Automation has been performed and Phase X was involved.</i>	Combination of (BO1, BO2, BO3, BO4, BO5, BO6, BO7, BO8, BO9, BO10, BO11, BO12, BO13, BO14, BO15, BO16, BO17, BO18, BO19, BO20, BO21, BO22, L1, L2, L3, L4, L5, L6, L7, L8, L9, L10, L11, L12, L13, L14, L15, L16, L17, L18, L19, L20, V1, V2, V3, V4, V5, V6, V7, V8, V9, V10, V11, V12, V13, V14, V15, V16)	----- ----- ----- ---	
LOV B <i>Loss Of Voltage Automation has been performed and Phase B was involved.</i>	Combination of (BO1, BO2, BO3, BO4, BO5, BO6, BO7, BO8, BO9, BO10, BO11, BO12, BO13, BO14, BO15, BO16, BO17, BO18, BO19, BO20, BO21, BO22, L1, L2, L3, L4, L5, L6, L7, L8, L9, L10, L11, L12, L13, L14, L15, L16, L17, L18, L19, L20, V1, V2, V3, V4, V5, V6, V7, V8, V9, V10, V11, V12, V13, V14, V15, V16)	----- ----- ----- ---	
LOV Y <i>Loss Of Voltage Automation has been performed and Phase Y was involved.</i>	Combination of (BO1, BO2, BO3, BO4, BO5, BO6, BO7, BO8, BO9, BO10, BO11, BO12, BO13, BO14, BO15, BO16, BO17, BO18, BO19, BO20, BO21, BO22, L1, L2, L3, L4, L5, L6, L7, L8, L9, L10, L11, L12, L13, L14, L15, L16, L17, L18, L19, L20, V1, V2, V3, V4, V5, V6, V7, V8, V9, V10, V11, V12, V13, V14, V15, V16)	----- ----- ----- ---	
LOV C <i>Loss Of Voltage Automation has been performed and Phase C was involved.</i>	Combination of (BO1, BO2, BO3, BO4, BO5, BO6, BO7, BO8, BO9, BO10, BO11, BO12, BO13, BO14, BO15, BO16, BO17, BO18, BO19, BO20, BO21, BO22, L1, L2, L3, L4, L5, L6, L7, L8, L9, L10, L11, L12, L13, L14, L15, L16, L17, L18, L19, L20, V1, V2, V3, V4, V5, V6, V7, V8, V9, V10, V11, V12, V13, V14, V15, V16)	----- ----- ----- ---	
LOV Z <i>Loss Of Voltage Automation has been performed and Phase Z was involved.</i>	Combination of (BO1, BO2, BO3, BO4, BO5, BO6, BO7, BO8, BO9, BO10, BO11, BO12, BO13, BO14, BO15, BO16, BO17, BO18, BO19, BO20, BO21, BO22, L1, L2, L3, L4, L5, L6, L7, L8, L9, L10, L11, L12, L13, L14, L15, L16, L17, L18, L19, L20, V1, V2, V3, V4, V5, V6, V7, V8, V9, V10, V11, V12, V13, V14, V15, V16)	----- ----- ----- ---	

Description	Range	Default	Setting
50BF-1 <i>Circuit Breaker Fail stage 1 operated</i>	Combination of (BO1, BO2, BO3, BO4, BO5, BO6, BO7, BO8, BO9, BO10, BO11, BO12, BO13, BO14, BO15, BO16, BO17, BO18, BO19, BO20, BO21, BO22, L1, L2, L3, L4, L5, L6, L7, L8, L9, L10, L11, L12, L13, L14, L15, L16, L17, L18, L19, L20, V1, V2, V3, V4, V5, V6, V7, V8, V9, V10, V11, V12, V13, V14, V15, V16)	----- ----- ----- ----	
50BF-2 <i>Circuit Breaker Fail stage 2 operated</i>	Combination of (BO1, BO2, BO3, BO4, BO5, BO6, BO7, BO8, BO9, BO10, BO11, BO12, BO13, BO14, BO15, BO16, BO17, BO18, BO19, BO20, BO21, BO22, L1, L2, L3, L4, L5, L6, L7, L8, L9, L10, L11, L12, L13, L14, L15, L16, L17, L18, L19, L20, V1, V2, V3, V4, V5, V6, V7, V8, V9, V10, V11, V12, V13, V14, V15, V16)	----- ----- ----- ----	
60VTS <i>VT Supervision element operated</i>	Combination of (BO1, BO2, BO3, BO4, BO5, BO6, BO7, BO8, BO9, BO10, BO11, BO12, BO13, BO14, BO15, BO16, BO17, BO18, BO19, BO20, BO21, BO22, L1, L2, L3, L4, L5, L6, L7, L8, L9, L10, L11, L12, L13, L14, L15, L16, L17, L18, L19, L20, V1, V2, V3, V4, V5, V6, V7, V8, V9, V10, V11, V12, V13, V14, V15, V16)	----- ----- ----- ----	
60VTS-X <i>VT Supervision element for x,y,x phases operated.</i>	Combination of (BO1, BO2, BO3, BO4, BO5, BO6, BO7, BO8, BO9, BO10, BO11, BO12, BO13, BO14, BO15, BO16, BO17, BO18, BO19, BO20, BO21, BO22, L1, L2, L3, L4, L5, L6, L7, L8, L9, L10, L11, L12, L13, L14, L15, L16, L17, L18, L19, L20, V1, V2, V3, V4, V5, V6, V7, V8, V9, V10, V11, V12, V13, V14, V15, V16)	----- ----- ----- ----	
CB Total Trip Count <i>Total CB trip count exceeded</i>	Combination of (BO1, BO2, BO3, BO4, BO5, BO6, BO7, BO8, BO9, BO10, BO11, BO12, BO13, BO14, BO15, BO16, BO17, BO18, BO19, BO20, BO21, BO22, L1, L2, L3, L4, L5, L6, L7, L8, L9, L10, L11, L12, L13, L14, L15, L16, L17, L18, L19, L20, V1, V2, V3, V4, V5, V6, V7, V8, V9, V10, V11, V12, V13, V14, V15, V16)	----- ----- ----- ----	

Description	Range	Default	Setting
CB Delta Trip Count <i>Delta CB trip count exceeded</i>	Combination of (BO1, BO2, BO3, BO4, BO5, BO6, BO7, BO8, BO9, BO10, BO11, BO12, BO13, BO14, BO15, BO16, BO17, BO18, BO19, BO20, BO21, BO22, L1, L2, L3, L4, L5, L6, L7, L8, L9, L10, L11, L12, L13, L14, L15, L16, L17, L18, L19, L20, V1, V2, V3, V4, V5, V6, V7, V8, V9, V10, V11, V12, V13, V14, V15, V16)	----- ----- ----- ----	
CB Count To ARBlock <i>Count To AR Block CB trip count exceeded</i>	Combination of (BO1, BO2, BO3, BO4, BO5, BO6, BO7, BO8, BO9, BO10, BO11, BO12, BO13, BO14, BO15, BO16, BO17, BO18, BO19, BO20, BO21, BO22, L1, L2, L3, L4, L5, L6, L7, L8, L9, L10, L11, L12, L13, L14, L15, L16, L17, L18, L19, L20, V1, V2, V3, V4, V5, V6, V7, V8, V9, V10, V11, V12, V13, V14, V15, V16)	----- ----- ----- ----	
CB Freq Ops Count <i>CB Frequent Operations count exceeded</i>	Combination of (BO1, BO2, BO3, BO4, BO5, BO6, BO7, BO8, BO9, BO10, BO11, BO12, BO13, BO14, BO15, BO16, BO17, BO18, BO19, BO20, BO21, BO22, L1, L2, L3, L4, L5, L6, L7, L8, L9, L10, L11, L12, L13, L14, L15, L16, L17, L18, L19, L20, V1, V2, V3, V4, V5, V6, V7, V8, V9, V10, V11, V12, V13, V14, V15, V16)	----- ----- ----- ----	
CB LO Handle Ops <i>CB Lockout Handle Operations count exceeded</i>	Combination of (BO1, BO2, BO3, BO4, BO5, BO6, BO7, BO8, BO9, BO10, BO11, BO12, BO13, BO14, BO15, BO16, BO17, BO18, BO19, BO20, BO21, BO22, L1, L2, L3, L4, L5, L6, L7, L8, L9, L10, L11, L12, L13, L14, L15, L16, L17, L18, L19, L20, V1, V2, V3, V4, V5, V6, V7, V8, V9, V10, V11, V12, V13, V14, V15, V16)	----- ----- ----- ----	
I ² t CB Wear <i>I²t CB Wear limit exceeded</i>	Combination of (BO1, BO2, BO3, BO4, BO5, BO6, BO7, BO8, BO9, BO10, BO11, BO12, BO13, BO14, BO15, BO16, BO17, BO18, BO19, BO20, BO21, BO22, L1, L2, L3, L4, L5, L6, L7, L8, L9, L10, L11, L12, L13, L14, L15, L16, L17, L18, L19, L20, V1, V2, V3, V4, V5, V6, V7, V8, V9, V10, V11, V12, V13, V14, V15, V16)	----- ----- ----- ----	

Description	Range	Default	Setting
<p>Battery Test</p> <p><i>Battery Test is in progress. This can be used to disable battery charger during a battery test.</i></p>	<p>Combination of (BO1, BO2, BO3, BO4, BO5, BO6, BO7, BO8, BO9, BO10, BO11, BO12, BO13, BO14, BO15, BO16, BO17, BO18, BO19, BO20, BO21, BO22, L1, L2, L3, L4, L5, L6, L7, L8, L9, L10, L11, L12, L13, L14, L15, L16, L17, L18, L19, L20, V1, V2, V3, V4, V5, V6, V7, V8, V9, V10, V11, V12, V13, V14, V15, V16)</p>	<p>----- ----- ----- ----</p>	
<p>Battery Load Test</p> <p><i>Battery Load Test is in progress. This can be used to apply the battery test load during a battery test.</i></p>	<p>Combination of (BO1, BO2, BO3, BO4, BO5, BO6, BO7, BO8, BO9, BO10, BO11, BO12, BO13, BO14, BO15, BO16, BO17, BO18, BO19, BO20, BO21, BO22, L1, L2, L3, L4, L5, L6, L7, L8, L9, L10, L11, L12, L13, L14, L15, L16, L17, L18, L19, L20, V1, V2, V3, V4, V5, V6, V7, V8, V9, V10, V11, V12, V13, V14, V15, V16)</p>	<p>----- ----- ----- ----</p>	
<p>Battery Test Pass</p> <p><i>Indicates whether the last battery test passed.</i></p>	<p>Combination of (BO1, BO2, BO3, BO4, BO5, BO6, BO7, BO8, BO9, BO10, BO11, BO12, BO13, BO14, BO15, BO16, BO17, BO18, BO19, BO20, BO21, BO22, L1, L2, L3, L4, L5, L6, L7, L8, L9, L10, L11, L12, L13, L14, L15, L16, L17, L18, L19, L20, V1, V2, V3, V4, V5, V6, V7, V8, V9, V10, V11, V12, V13, V14, V15, V16)</p>	<p>----- ----- ----- ----</p>	
<p>Battery Test Fail</p> <p><i>Indicates whether the last battery test failed.</i></p>	<p>Combination of (BO1, BO2, BO3, BO4, BO5, BO6, BO7, BO8, BO9, BO10, BO11, BO12, BO13, BO14, BO15, BO16, BO17, BO18, BO19, BO20, BO21, BO22, L1, L2, L3, L4, L5, L6, L7, L8, L9, L10, L11, L12, L13, L14, L15, L16, L17, L18, L19, L20, V1, V2, V3, V4, V5, V6, V7, V8, V9, V10, V11, V12, V13, V14, V15, V16)</p>	<p>----- ----- ----- ----</p>	
<p>Recovery Fail</p> <p><i>Indicates whether the battery failed to recover back to its pre-test voltage after last battery test.</i></p>	<p>Combination of (BO1, BO2, BO3, BO4, BO5, BO6, BO7, BO8, BO9, BO10, BO11, BO12, BO13, BO14, BO15, BO16, BO17, BO18, BO19, BO20, BO21, BO22, L1, L2, L3, L4, L5, L6, L7, L8, L9, L10, L11, L12, L13, L14, L15, L16, L17, L18, L19, L20, V1, V2, V3, V4, V5, V6, V7, V8, V9, V10, V11, V12, V13, V14, V15, V16)</p>	<p>----- ----- ----- ----</p>	

Description	Range	Default	Setting
<p>Ext. Power Good <i>Indicates whether the external battery supply is ok.</i></p>	<p>Combination of (BO1, BO2, BO3, BO4, BO5, BO6, BO7, BO8, BO9, BO10, BO11, BO12, BO13, BO14, BO15, BO16, BO17, BO18, BO19, BO20, BO21, BO22, L1, L2, L3, L4, L5, L6, L7, L8, L9, L10, L11, L12, L13, L14, L15, L16, L17, L18, L19, L20, V1, V2, V3, V4, V5, V6, V7, V8, V9, V10, V11, V12, V13, V14, V15, V16)</p>	<p>----- ----- ----- ---</p>	
<p>Battery Healthy <i>Indicates whether the current battery voltage is healthy</i></p>	<p>Combination of (BO1, BO2, BO3, BO4, BO5, BO6, BO7, BO8, BO9, BO10, BO11, BO12, BO13, BO14, BO15, BO16, BO17, BO18, BO19, BO20, BO21, BO22, L1, L2, L3, L4, L5, L6, L7, L8, L9, L10, L11, L12, L13, L14, L15, L16, L17, L18, L19, L20, V1, V2, V3, V4, V5, V6, V7, V8, V9, V10, V11, V12, V13, V14, V15, V16)</p>	<p>----- ----- ----- ---</p>	
<p>Capacitor Ready <i>Indicates whether the current capacitor status is ready to trip and close.</i></p>	<p>Combination of (BO1, BO2, BO3, BO4, BO5, BO6, BO7, BO8, BO9, BO10, BO11, BO12, BO13, BO14, BO15, BO16, BO17, BO18, BO19, BO20, BO21, BO22, L1, L2, L3, L4, L5, L6, L7, L8, L9, L10, L11, L12, L13, L14, L15, L16, L17, L18, L19, L20, V1, V2, V3, V4, V5, V6, V7, V8, V9, V10, V11, V12, V13, V14, V15, V16)</p>	<p>----- ----- ----- ---</p>	
<p>CapacitorSupplyFail <i>Indicates whether the current capacitor status is Supply Failed.</i></p>	<p>Combination of (BO1, BO2, BO3, BO4, BO5, BO6, BO7, BO8, BO9, BO10, BO11, BO12, BO13, BO14, BO15, BO16, BO17, BO18, BO19, BO20, BO21, BO22, L1, L2, L3, L4, L5, L6, L7, L8, L9, L10, L11, L12, L13, L14, L15, L16, L17, L18, L19, L20, V1, V2, V3, V4, V5, V6, V7, V8, V9, V10, V11, V12, V13, V14, V15, V16)</p>	<p>----- ----- ----- ---</p>	
<p>Capacitor Only Trip <i>Indicates whether the current capacitor status is Only Trip.</i></p>	<p>Combination of (BO1, BO2, BO3, BO4, BO5, BO6, BO7, BO8, BO9, BO10, BO11, BO12, BO13, BO14, BO15, BO16, BO17, BO18, BO19, BO20, BO21, BO22, L1, L2, L3, L4, L5, L6, L7, L8, L9, L10, L11, L12, L13, L14, L15, L16, L17, L18, L19, L20, V1, V2, V3, V4, V5, V6, V7, V8, V9, V10, V11, V12, V13, V14, V15, V16)</p>	<p>----- ----- ----- ---</p>	

Description	Range	Default	Setting
<p>Capacitor DBI <i>Indicates whether the current capacitor status is DBI condition.</i></p>	<p>Combination of (BO1, BO2, BO3, BO4, BO5, BO6, BO7, BO8, BO9, BO10, BO11, BO12, BO13, BO14, BO15, BO16, BO17, BO18, BO19, BO20, BO21, BO22, L1, L2, L3, L4, L5, L6, L7, L8, L9, L10, L11, L12, L13, L14, L15, L16, L17, L18, L19, L20, V1, V2, V3, V4, V5, V6, V7, V8, V9, V10, V11, V12, V13, V14, V15, V16)</p>	<p>----- ----- ----- ----</p>	
<p>Cap Test Active <i>Capacitor Test is in progress.</i></p>	<p>Combination of (BO1, BO2, BO3, BO4, BO5, BO6, BO7, BO8, BO9, BO10, BO11, BO12, BO13, BO14, BO15, BO16, BO17, BO18, BO19, BO20, BO21, BO22, L1, L2, L3, L4, L5, L6, L7, L8, L9, L10, L11, L12, L13, L14, L15, L16, L17, L18, L19, L20, V1, V2, V3, V4, V5, V6, V7, V8, V9, V10, V11, V12, V13, V14, V15, V16)</p>	<p>----- ----- ----- ----</p>	
<p>Cap Test Pass <i>Indicates whether the last capacitor test passed.</i></p>	<p>Combination of (BO1, BO2, BO3, BO4, BO5, BO6, BO7, BO8, BO9, BO10, BO11, BO12, BO13, BO14, BO15, BO16, BO17, BO18, BO19, BO20, BO21, BO22, L1, L2, L3, L4, L5, L6, L7, L8, L9, L10, L11, L12, L13, L14, L15, L16, L17, L18, L19, L20, V1, V2, V3, V4, V5, V6, V7, V8, V9, V10, V11, V12, V13, V14, V15, V16)</p>	<p>----- ----- ----- ----</p>	
<p>Cap Test Fail <i>Indicates whether the last capacitor test failed.</i></p>	<p>Combination of (BO1, BO2, BO3, BO4, BO5, BO6, BO7, BO8, BO9, BO10, BO11, BO12, BO13, BO14, BO15, BO16, BO17, BO18, BO19, BO20, BO21, BO22, L1, L2, L3, L4, L5, L6, L7, L8, L9, L10, L11, L12, L13, L14, L15, L16, L17, L18, L19, L20, V1, V2, V3, V4, V5, V6, V7, V8, V9, V10, V11, V12, V13, V14, V15, V16)</p>	<p>----- ----- ----- ----</p>	
<p>Cap Recovery Fail <i>Indicates whether the capacitor voltage failed to recover after the last capacitor test.</i></p>	<p>Combination of (BO1, BO2, BO3, BO4, BO5, BO6, BO7, BO8, BO9, BO10, BO11, BO12, BO13, BO14, BO15, BO16, BO17, BO18, BO19, BO20, BO21, BO22, L1, L2, L3, L4, L5, L6, L7, L8, L9, L10, L11, L12, L13, L14, L15, L16, L17, L18, L19, L20, V1, V2, V3, V4, V5, V6, V7, V8, V9, V10, V11, V12, V13, V14, V15, V16)</p>	<p>----- ----- ----- ----</p>	

Description	Range	Default	Setting
27Sag Pole1 SARFI <i>Voltage has dropped below the defined SARFI level on Pole 1.</i>	Combination of (BO1, BO2, BO3, BO4, BO5, BO6, BO7, BO8, BO9, BO10, BO11, BO12, BO13, BO14, BO15, BO16, BO17, BO18, BO19, BO20, BO21, BO22, L1, L2, L3, L4, L5, L6, L7, L8, L9, L10, L11, L12, L13, L14, L15, L16, L17, L18, L19, L20, V1, V2, V3, V4, V5, V6, V7, V8, V9, V10, V11, V12, V13, V14, V15, V16)	----- ----- ----- ---	
27Sag Pole2 SARFI <i>Voltage has dropped below the defined SARFI level on Pole 2.</i>	Combination of (BO1, BO2, BO3, BO4, BO5, BO6, BO7, BO8, BO9, BO10, BO11, BO12, BO13, BO14, BO15, BO16, BO17, BO18, BO19, BO20, BO21, BO22, L1, L2, L3, L4, L5, L6, L7, L8, L9, L10, L11, L12, L13, L14, L15, L16, L17, L18, L19, L20, V1, V2, V3, V4, V5, V6, V7, V8, V9, V10, V11, V12, V13, V14, V15, V16)	----- ----- ----- ---	
27Sag Pole3 SARFI <i>Voltage has dropped below the defined SARFI level on Pole 3.</i>	Combination of (BO1, BO2, BO3, BO4, BO5, BO6, BO7, BO8, BO9, BO10, BO11, BO12, BO13, BO14, BO15, BO16, BO17, BO18, BO19, BO20, BO21, BO22, L1, L2, L3, L4, L5, L6, L7, L8, L9, L10, L11, L12, L13, L14, L15, L16, L17, L18, L19, L20, V1, V2, V3, V4, V5, V6, V7, V8, V9, V10, V11, V12, V13, V14, V15, V16)	----- ----- ----- ---	
59Swell Pole1 SARFI <i>Voltage has risen above the defined SARFI level on Pole 1.</i>	Combination of (BO1, BO2, BO3, BO4, BO5, BO6, BO7, BO8, BO9, BO10, BO11, BO12, BO13, BO14, BO15, BO16, BO17, BO18, BO19, BO20, BO21, BO22, L1, L2, L3, L4, L5, L6, L7, L8, L9, L10, L11, L12, L13, L14, L15, L16, L17, L18, L19, L20, V1, V2, V3, V4, V5, V6, V7, V8, V9, V10, V11, V12, V13, V14, V15, V16)	----- ----- ----- ---	
59Swell Pole2 SARFI <i>Voltage has risen above the defined SARFI level on Pole 2.</i>	Combination of (BO1, BO2, BO3, BO4, BO5, BO6, BO7, BO8, BO9, BO10, BO11, BO12, BO13, BO14, BO15, BO16, BO17, BO18, BO19, BO20, BO21, BO22, L1, L2, L3, L4, L5, L6, L7, L8, L9, L10, L11, L12, L13, L14, L15, L16, L17, L18, L19, L20, V1, V2, V3, V4, V5, V6, V7, V8, V9, V10, V11, V12, V13, V14, V15, V16)	----- ----- ----- ---	

Description	Range	Default	Setting
59Swell Pole3 SARFI <i>Voltage has risen above the defined SARFI level on Pole 3.</i>	Combination of (BO1, BO2, BO3, BO4, BO5, BO6, BO7, BO8, BO9, BO10, BO11, BO12, BO13, BO14, BO15, BO16, BO17, BO18, BO19, BO20, BO21, BO22, L1, L2, L3, L4, L5, L6, L7, L8, L9, L10, L11, L12, L13, L14, L15, L16, L17, L18, L19, L20, V1, V2, V3, V4, V5, V6, V7, V8, V9, V10, V11, V12, V13, V14, V15, V16)	----- ----- ----- ---	
Phase A <i>A phase A element operated</i>	Combination of (BO1, BO2, BO3, BO4, BO5, BO6, BO7, BO8, BO9, BO10, BO11, BO12, BO13, BO14, BO15, BO16, BO17, BO18, BO19, BO20, BO21, BO22, L1, L2, L3, L4, L5, L6, L7, L8, L9, L10, L11, L12, L13, L14, L15, L16, L17, L18, L19, L20, V1, V2, V3, V4, V5, V6, V7, V8, V9, V10, V11, V12, V13, V14, V15, V16)	L1	
Phase B <i>A phase B element operated</i>	Combination of (BO1, BO2, BO3, BO4, BO5, BO6, BO7, BO8, BO9, BO10, BO11, BO12, BO13, BO14, BO15, BO16, BO17, BO18, BO19, BO20, BO21, BO22, L1, L2, L3, L4, L5, L6, L7, L8, L9, L10, L11, L12, L13, L14, L15, L16, L17, L18, L19, L20, V1, V2, V3, V4, V5, V6, V7, V8, V9, V10, V11, V12, V13, V14, V15, V16)	L2	
Phase C <i>A phase C element operated</i>	Combination of (BO1, BO2, BO3, BO4, BO5, BO6, BO7, BO8, BO9, BO10, BO11, BO12, BO13, BO14, BO15, BO16, BO17, BO18, BO19, BO20, BO21, BO22, L1, L2, L3, L4, L5, L6, L7, L8, L9, L10, L11, L12, L13, L14, L15, L16, L17, L18, L19, L20, V1, V2, V3, V4, V5, V6, V7, V8, V9, V10, V11, V12, V13, V14, V15, V16)	L3	
Forward P/F <i>The Phase fault is in the forward direction. Note this output is presented EVEN when relay elements are set to be non-directional.</i>	Combination of (BO1, BO2, BO3, BO4, BO5, BO6, BO7, BO8, BO9, BO10, BO11, BO12, BO13, BO14, BO15, BO16, BO17, BO18, BO19, BO20, BO21, BO22, L1, L2, L3, L4, L5, L6, L7, L8, L9, L10, L11, L12, L13, L14, L15, L16, L17, L18, L19, L20, V1, V2, V3, V4, V5, V6, V7, V8, V9, V10, V11, V12, V13, V14, V15, V16)	----- ----- ----- ---	

Description	Range	Default	Setting
<p>Reverse P/F</p> <p><i>The Phase fault is in the reverse direction. Note this output is presented EVEN when relay elements are set to be non-directional.</i></p>	<p>Combination of (BO1, BO2, BO3, BO4, BO5, BO6, BO7, BO8, BO9, BO10, BO11, BO12, BO13, BO14, BO15, BO16, BO17, BO18, BO19, BO20, BO21, BO22, L1, L2, L3, L4, L5, L6, L7, L8, L9, L10, L11, L12, L13, L14, L15, L16, L17, L18, L19, L20, V1, V2, V3, V4, V5, V6, V7, V8, V9, V10, V11, V12, V13, V14, V15, V16)</p>	<p>----- ----- ----- ----</p>	
<p>Forward E/F</p> <p><i>The fault is in the forward direction. Note this output is presented EVEN when relay elements are set to be non-directional.</i></p>	<p>Combination of (BO1, BO2, BO3, BO4, BO5, BO6, BO7, BO8, BO9, BO10, BO11, BO12, BO13, BO14, BO15, BO16, BO17, BO18, BO19, BO20, BO21, BO22, L1, L2, L3, L4, L5, L6, L7, L8, L9, L10, L11, L12, L13, L14, L15, L16, L17, L18, L19, L20, V1, V2, V3, V4, V5, V6, V7, V8, V9, V10, V11, V12, V13, V14, V15, V16)</p>	<p>----- ----- ----- ----</p>	
<p>Reverse E/F</p> <p><i>The fault is in the reverse direction. Note this output is presented EVEN when relay elements are set to be non-directional.</i></p>	<p>Combination of (BO1, BO2, BO3, BO4, BO5, BO6, BO7, BO8, BO9, BO10, BO11, BO12, BO13, BO14, BO15, BO16, BO17, BO18, BO19, BO20, BO21, BO22, L1, L2, L3, L4, L5, L6, L7, L8, L9, L10, L11, L12, L13, L14, L15, L16, L17, L18, L19, L20, V1, V2, V3, V4, V5, V6, V7, V8, V9, V10, V11, V12, V13, V14, V15, V16)</p>	<p>----- ----- ----- ----</p>	
<p>Forward SEF</p> <p><i>The fault is in the forward direction. Note this output is presented EVEN when relay elements are set to be non-directional.</i></p>	<p>Combination of (BO1, BO2, BO3, BO4, BO5, BO6, BO7, BO8, BO9, BO10, BO11, BO12, BO13, BO14, BO15, BO16, BO17, BO18, BO19, BO20, BO21, BO22, L1, L2, L3, L4, L5, L6, L7, L8, L9, L10, L11, L12, L13, L14, L15, L16, L17, L18, L19, L20, V1, V2, V3, V4, V5, V6, V7, V8, V9, V10, V11, V12, V13, V14, V15, V16)</p>	<p>----- ----- ----- ----</p>	
<p>Reverse SEF</p> <p><i>The fault is in the reverse direction. Note this output is presented EVEN when relay elements are set to be non-directional.</i></p>	<p>Combination of (BO1, BO2, BO3, BO4, BO5, BO6, BO7, BO8, BO9, BO10, BO11, BO12, BO13, BO14, BO15, BO16, BO17, BO18, BO19, BO20, BO21, BO22, L1, L2, L3, L4, L5, L6, L7, L8, L9, L10, L11, L12, L13, L14, L15, L16, L17, L18, L19, L20, V1, V2, V3, V4, V5, V6, V7, V8, V9, V10, V11, V12, V13, V14, V15, V16)</p>	<p>----- ----- ----- ----</p>	

Description	Range	Default	Setting
<p>Close CB Blocked</p> <p><i>Indicates that the Close CB control is blocked by its interlocking logic.</i></p>	<p>Combination of (BO1, BO2, BO3, BO4, BO5, BO6, BO7, BO8, BO9, BO10, BO11, BO12, BO13, BO14, BO15, BO16, BO17, BO18, BO19, BO20, BO21, BO22, L1, L2, L3, L4, L5, L6, L7, L8, L9, L10, L11, L12, L13, L14, L15, L16, L17, L18, L19, L20, V1, V2, V3, V4, V5, V6, V7, V8, V9, V10, V11, V12, V13, V14, V15, V16)</p>	<p>-----</p> <p>-----</p> <p>-----</p> <p>----</p>	
<p>Open CB</p> <p><i>Open pulse due to Manual Open being issued.</i></p>	<p>Combination of (BO1, BO2, BO3, BO4, BO5, BO6, BO7, BO8, BO9, BO10, BO11, BO12, BO13, BO14, BO15, BO16, BO17, BO18, BO19, BO20, BO21, BO22, L1, L2, L3, L4, L5, L6, L7, L8, L9, L10, L11, L12, L13, L14, L15, L16, L17, L18, L19, L20, V1, V2, V3, V4, V5, V6, V7, V8, V9, V10, V11, V12, V13, V14, V15, V16)</p>	<p>-----</p> <p>-----</p> <p>-----</p> <p>----</p>	
<p>CB Alarm</p> <p><i>Indicates the CB is either in an illegal state or is stuck neither open or closed.</i></p>	<p>Combination of (BO1, BO2, BO3, BO4, BO5, BO6, BO7, BO8, BO9, BO10, BO11, BO12, BO13, BO14, BO15, BO16, BO17, BO18, BO19, BO20, BO21, BO22, L1, L2, L3, L4, L5, L6, L7, L8, L9, L10, L11, L12, L13, L14, L15, L16, L17, L18, L19, L20, V1, V2, V3, V4, V5, V6, V7, V8, V9, V10, V11, V12, V13, V14, V15, V16)</p>	<p>-----</p> <p>-----</p> <p>-----</p> <p>----</p>	
<p>CB Closed</p> <p><i>Indicates that the circuit breaker is in the closed position.</i></p>	<p>Combination of (BO1, BO2, BO3, BO4, BO5, BO6, BO7, BO8, BO9, BO10, BO11, BO12, BO13, BO14, BO15, BO16, BO17, BO18, BO19, BO20, BO21, BO22, L1, L2, L3, L4, L5, L6, L7, L8, L9, L10, L11, L12, L13, L14, L15, L16, L17, L18, L19, L20, V1, V2, V3, V4, V5, V6, V7, V8, V9, V10, V11, V12, V13, V14, V15, V16)</p>	<p>-----</p> <p>-----</p> <p>-----</p> <p>----</p>	
<p>CB Open</p> <p><i>Indicates that the circuit breaker is in the open position.</i></p>	<p>Combination of (BO1, BO2, BO3, BO4, BO5, BO6, BO7, BO8, BO9, BO10, BO11, BO12, BO13, BO14, BO15, BO16, BO17, BO18, BO19, BO20, BO21, BO22, L1, L2, L3, L4, L5, L6, L7, L8, L9, L10, L11, L12, L13, L14, L15, L16, L17, L18, L19, L20, V1, V2, V3, V4, V5, V6, V7, V8, V9, V10, V11, V12, V13, V14, V15, V16)</p>	<p>-----</p> <p>-----</p> <p>-----</p> <p>----</p>	

Description	Range	Default	Setting
Manual Close CB <i>Close pulse due to Manual close being issued</i>	Combination of (BO1, BO2, BO3, BO4, BO5, BO6, BO7, BO8, BO9, BO10, BO11, BO12, BO13, BO14, BO15, BO16, BO17, BO18, BO19, BO20, BO21, BO22, L1, L2, L3, L4, L5, L6, L7, L8, L9, L10, L11, L12, L13, L14, L15, L16, L17, L18, L19, L20, V1, V2, V3, V4, V5, V6, V7, V8, V9, V10, V11, V12, V13, V14, V15, V16)	----- ----- ----- ----	
79 AR Close CB <i>Close pulse due to auto-reclose sequence</i>	Combination of (BO1, BO2, BO3, BO4, BO5, BO6, BO7, BO8, BO9, BO10, BO11, BO12, BO13, BO14, BO15, BO16, BO17, BO18, BO19, BO20, BO21, BO22, L1, L2, L3, L4, L5, L6, L7, L8, L9, L10, L11, L12, L13, L14, L15, L16, L17, L18, L19, L20, V1, V2, V3, V4, V5, V6, V7, V8, V9, V10, V11, V12, V13, V14, V15, V16)	----- ----- ----- ----	
79 Trip & Reclose <i>Indicates the Trip & Reclose sequence being performed</i>	Combination of (BO1, BO2, BO3, BO4, BO5, BO6, BO7, BO8, BO9, BO10, BO11, BO12, BO13, BO14, BO15, BO16, BO17, BO18, BO19, BO20, BO21, BO22, L1, L2, L3, L4, L5, L6, L7, L8, L9, L10, L11, L12, L13, L14, L15, L16, L17, L18, L19, L20, V1, V2, V3, V4, V5, V6, V7, V8, V9, V10, V11, V12, V13, V14, V15, V16)	----- ----- ----- ----	
79 Trip & Lockout <i>Indicates the Trip & Lockout sequence being performed</i>	Combination of (BO1, BO2, BO3, BO4, BO5, BO6, BO7, BO8, BO9, BO10, BO11, BO12, BO13, BO14, BO15, BO16, BO17, BO18, BO19, BO20, BO21, BO22, L1, L2, L3, L4, L5, L6, L7, L8, L9, L10, L11, L12, L13, L14, L15, L16, L17, L18, L19, L20, V1, V2, V3, V4, V5, V6, V7, V8, V9, V10, V11, V12, V13, V14, V15, V16)	----- ----- ----- ----	
79 Lockout <i>Indicates the auto-recloser is in the Lockout state</i>	Combination of (BO1, BO2, BO3, BO4, BO5, BO6, BO7, BO8, BO9, BO10, BO11, BO12, BO13, BO14, BO15, BO16, BO17, BO18, BO19, BO20, BO21, BO22, L1, L2, L3, L4, L5, L6, L7, L8, L9, L10, L11, L12, L13, L14, L15, L16, L17, L18, L19, L20, V1, V2, V3, V4, V5, V6, V7, V8, V9, V10, V11, V12, V13, V14, V15, V16)	----- ----- ----- ----	

Description	Range	Default	Setting
<p>79 Out Of Service <i>Indicates the auto-recloser is out of service</i></p>	<p>Combination of (BO1, BO2, BO3, BO4, BO5, BO6, BO7, BO8, BO9, BO10, BO11, BO12, BO13, BO14, BO15, BO16, BO17, BO18, BO19, BO20, BO21, BO22, L1, L2, L3, L4, L5, L6, L7, L8, L9, L10, L11, L12, L13, L14, L15, L16, L17, L18, L19, L20, V1, V2, V3, V4, V5, V6, V7, V8, V9, V10, V11, V12, V13, V14, V15, V16)</p>	<p>----- ----- ----- ----</p>	
<p>79 In Service <i>Indicates the auto-recloser is in service</i></p>	<p>Combination of (BO1, BO2, BO3, BO4, BO5, BO6, BO7, BO8, BO9, BO10, BO11, BO12, BO13, BO14, BO15, BO16, BO17, BO18, BO19, BO20, BO21, BO22, L1, L2, L3, L4, L5, L6, L7, L8, L9, L10, L11, L12, L13, L14, L15, L16, L17, L18, L19, L20, V1, V2, V3, V4, V5, V6, V7, V8, V9, V10, V11, V12, V13, V14, V15, V16)</p>	<p>----- ----- ----- ----</p>	
<p>79 In Progress <i>Indicates an auto-reclose sequence is in progress</i></p>	<p>Combination of (BO1, BO2, BO3, BO4, BO5, BO6, BO7, BO8, BO9, BO10, BO11, BO12, BO13, BO14, BO15, BO16, BO17, BO18, BO19, BO20, BO21, BO22, L1, L2, L3, L4, L5, L6, L7, L8, L9, L10, L11, L12, L13, L14, L15, L16, L17, L18, L19, L20, V1, V2, V3, V4, V5, V6, V7, V8, V9, V10, V11, V12, V13, V14, V15, V16)</p>	<p>----- ----- ----- ----</p>	
<p>79 Block Extern <i>Indicates that Extern for the current shot has been selected to be delayed. (This may be used to block external tripping elements in the same way as the internal protection elements are blocked to achieve Instantaneous / Delayed operation.)</i></p>	<p>Combination of (BO1, BO2, BO3, BO4, BO5, BO6, BO7, BO8, BO9, BO10, BO11, BO12, BO13, BO14, BO15, BO16, BO17, BO18, BO19, BO20, BO21, BO22, L1, L2, L3, L4, L5, L6, L7, L8, L9, L10, L11, L12, L13, L14, L15, L16, L17, L18, L19, L20, V1, V2, V3, V4, V5, V6, V7, V8, V9, V10, V11, V12, V13, V14, V15, V16)</p>	<p>----- ----- ----- ----</p>	
<p>79 CB Fail To Close <i>Indicates the CB was not closed at the end of the Close Pulse</i></p>	<p>Combination of (BO1, BO2, BO3, BO4, BO5, BO6, BO7, BO8, BO9, BO10, BO11, BO12, BO13, BO14, BO15, BO16, BO17, BO18, BO19, BO20, BO21, BO22, L1, L2, L3, L4, L5, L6, L7, L8, L9, L10, L11, L12, L13, L14, L15, L16, L17, L18, L19, L20, V1, V2, V3, V4, V5, V6, V7, V8, V9, V10, V11, V12, V13, V14, V15, V16)</p>	<p>----- ----- ----- ----</p>	

Description	Range	Default	Setting
<p>79 Close Onto Fault <i>Indicates an element starter or trip operated during the Close Pulse</i></p>	<p>Combination of (BO1, BO2, BO3, BO4, BO5, BO6, BO7, BO8, BO9, BO10, BO11, BO12, BO13, BO14, BO15, BO16, BO17, BO18, BO19, BO20, BO21, BO22, L1, L2, L3, L4, L5, L6, L7, L8, L9, L10, L11, L12, L13, L14, L15, L16, L17, L18, L19, L20, V1, V2, V3, V4, V5, V6, V7, V8, V9, V10, V11, V12, V13, V14, V15, V16)</p>	<p>----- ----- ----- ---</p>	
<p>79 Successful AR <i>Indicates that after a reclose and at the end of the Reclaim time the CB was closed and there were no auto-reclose trip elements operated. (This is issued for 2 secs)</i></p>	<p>Combination of (BO1, BO2, BO3, BO4, BO5, BO6, BO7, BO8, BO9, BO10, BO11, BO12, BO13, BO14, BO15, BO16, BO17, BO18, BO19, BO20, BO21, BO22, L1, L2, L3, L4, L5, L6, L7, L8, L9, L10, L11, L12, L13, L14, L15, L16, L17, L18, L19, L20, V1, V2, V3, V4, V5, V6, V7, V8, V9, V10, V11, V12, V13, V14, V15, V16)</p>	<p>----- ----- ----- ---</p>	
<p>Successful Man Close <i>Indicates that after a manual close and at the end of the Reclaim time the CB was closed and there were no auto-reclose trip elements operated. (This is issued for 2 secs)</i></p>	<p>Combination of (BO1, BO2, BO3, BO4, BO5, BO6, BO7, BO8, BO9, BO10, BO11, BO12, BO13, BO14, BO15, BO16, BO17, BO18, BO19, BO20, BO21, BO22, L1, L2, L3, L4, L5, L6, L7, L8, L9, L10, L11, L12, L13, L14, L15, L16, L17, L18, L19, L20, V1, V2, V3, V4, V5, V6, V7, V8, V9, V10, V11, V12, V13, V14, V15, V16)</p>	<p>----- ----- ----- ---</p>	
<p>Hot Line Working <i>Indicates that Hot LineWorking functionality has been selected</i></p>	<p>Combination of (BO1, BO2, BO3, BO4, BO5, BO6, BO7, BO8, BO9, BO10, BO11, BO12, BO13, BO14, BO15, BO16, BO17, BO18, BO19, BO20, BO21, BO22, L1, L2, L3, L4, L5, L6, L7, L8, L9, L10, L11, L12, L13, L14, L15, L16, L17, L18, L19, L20, V1, V2, V3, V4, V5, V6, V7, V8, V9, V10, V11, V12, V13, V14, V15, V16)</p>	<p>----- ----- ----- ---</p>	
<p>Inst Prot'n Out <i>Indicates that the protection elements selected to be Instantaneous elements are switched out</i></p>	<p>Combination of (BO1, BO2, BO3, BO4, BO5, BO6, BO7, BO8, BO9, BO10, BO11, BO12, BO13, BO14, BO15, BO16, BO17, BO18, BO19, BO20, BO21, BO22, L1, L2, L3, L4, L5, L6, L7, L8, L9, L10, L11, L12, L13, L14, L15, L16, L17, L18, L19, L20, V1, V2, V3, V4, V5, V6, V7, V8, V9, V10, V11, V12, V13, V14, V15, V16)</p>	<p>----- ----- ----- ---</p>	

Description	Range	Default	Setting
<p>E/F Out</p> <p><i>Indicates that the instantaneous protection elements are switched out.</i></p>	<p>Combination of (BO1, BO2, BO3, BO4, BO5, BO6, BO7, BO8, BO9, BO10, BO11, BO12, BO13, BO14, BO15, BO16, BO17, BO18, BO19, BO20, BO21, BO22, L1, L2, L3, L4, L5, L6, L7, L8, L9, L10, L11, L12, L13, L14, L15, L16, L17, L18, L19, L20, V1, V2, V3, V4, V5, V6, V7, V8, V9, V10, V11, V12, V13, V14, V15, V16)</p>	<p>-----</p> <p>-----</p> <p>-----</p> <p>----</p>	
<p>SEF Out</p> <p><i>Indicates that the SEF protection elements are switched out</i></p>	<p>Combination of (BO1, BO2, BO3, BO4, BO5, BO6, BO7, BO8, BO9, BO10, BO11, BO12, BO13, BO14, BO15, BO16, BO17, BO18, BO19, BO20, BO21, BO22, L1, L2, L3, L4, L5, L6, L7, L8, L9, L10, L11, L12, L13, L14, L15, L16, L17, L18, L19, L20, V1, V2, V3, V4, V5, V6, V7, V8, V9, V10, V11, V12, V13, V14, V15, V16)</p>	<p>-----</p> <p>-----</p> <p>-----</p> <p>----</p>	
<p>LOV Out</p> <p><i>Selects which inputs will switch out the LOV Automation</i></p>	<p>Combination of (BO1, BO2, BO3, BO4, BO5, BO6, BO7, BO8, BO9, BO10, BO11, BO12, BO13, BO14, BO15, BO16, BO17, BO18, BO19, BO20, BO21, BO22, L1, L2, L3, L4, L5, L6, L7, L8, L9, L10, L11, L12, L13, L14, L15, L16, L17, L18, L19, L20, V1, V2, V3, V4, V5, V6, V7, V8, V9, V10, V11, V12, V13, V14, V15, V16)</p>	<p>-----</p> <p>-----</p> <p>-----</p> <p>----</p>	
<p>New Wave Stored</p> <p><i>The waveform recorder has stored new information Note: this is a pulsed output</i></p>	<p>Combination of (BO1, BO2, BO3, BO4, BO5, BO6, BO7, BO8, BO9, BO10, BO11, BO12, BO13, BO14, BO15, BO16, BO17, BO18, BO19, BO20, BO21, BO22, L1, L2, L3, L4, L5, L6, L7, L8, L9, L10, L11, L12, L13, L14, L15, L16, L17, L18, L19, L20, V1, V2, V3, V4, V5, V6, V7, V8, V9, V10, V11, V12, V13, V14, V15, V16)</p>	<p>-----</p> <p>-----</p> <p>-----</p> <p>----</p>	
<p>New Fault Stored</p> <p><i>The fault recorder has stored new information Note: this is a pulsed output</i></p>	<p>Combination of (BO1, BO2, BO3, BO4, BO5, BO6, BO7, BO8, BO9, BO10, BO11, BO12, BO13, BO14, BO15, BO16, BO17, BO18, BO19, BO20, BO21, BO22, L1, L2, L3, L4, L5, L6, L7, L8, L9, L10, L11, L12, L13, L14, L15, L16, L17, L18, L19, L20, V1, V2, V3, V4, V5, V6, V7, V8, V9, V10, V11, V12, V13, V14, V15, V16)</p>	<p>-----</p> <p>-----</p> <p>-----</p> <p>----</p>	

Description	Range	Default	Setting
Active Exp Pulse	Combination of (BO1, BO2, BO3, BO4, BO5, BO6, BO7, BO8, BO9, BO10, BO11, BO12, BO13, BO14, BO15, BO16, BO17, BO18, BO19, BO20, BO21, BO22, L1, L2, L3, L4, L5, L6, L7, L8, L9, L10, L11, L12, L13, L14, L15, L16, L17, L18, L19, L20, V1, V2, V3, V4, V5, V6, V7, V8, V9, V10, V11, V12, V13, V14, V15, V16)	----- ----- ----- ----	
Active Imp Pulse	Combination of (BO1, BO2, BO3, BO4, BO5, BO6, BO7, BO8, BO9, BO10, BO11, BO12, BO13, BO14, BO15, BO16, BO17, BO18, BO19, BO20, BO21, BO22, L1, L2, L3, L4, L5, L6, L7, L8, L9, L10, L11, L12, L13, L14, L15, L16, L17, L18, L19, L20, V1, V2, V3, V4, V5, V6, V7, V8, V9, V10, V11, V12, V13, V14, V15, V16)	----- ----- ----- ----	
Reactive Exp Pulse	Combination of (BO1, BO2, BO3, BO4, BO5, BO6, BO7, BO8, BO9, BO10, BO11, BO12, BO13, BO14, BO15, BO16, BO17, BO18, BO19, BO20, BO21, BO22, L1, L2, L3, L4, L5, L6, L7, L8, L9, L10, L11, L12, L13, L14, L15, L16, L17, L18, L19, L20, V1, V2, V3, V4, V5, V6, V7, V8, V9, V10, V11, V12, V13, V14, V15, V16)	----- ----- ----- ----	
Reactive Imp Pulse	Combination of (BO1, BO2, BO3, BO4, BO5, BO6, BO7, BO8, BO9, BO10, BO11, BO12, BO13, BO14, BO15, BO16, BO17, BO18, BO19, BO20, BO21, BO22, L1, L2, L3, L4, L5, L6, L7, L8, L9, L10, L11, L12, L13, L14, L15, L16, L17, L18, L19, L20, V1, V2, V3, V4, V5, V6, V7, V8, V9, V10, V11, V12, V13, V14, V15, V16)	----- ----- ----- ----	
Out Of Service Mode <i>Indicates the relay is in Out Of Service Mode</i>	Combination of (BO1, BO2, BO3, BO4, BO5, BO6, BO7, BO8, BO9, BO10, BO11, BO12, BO13, BO14, BO15, BO16, BO17, BO18, BO19, BO20, BO21, BO22, L1, L2, L3, L4, L5, L6, L7, L8, L9, L10, L11, L12, L13, L14, L15, L16, L17, L18, L19, L20, V1, V2, V3, V4, V5, V6, V7, V8, V9, V10, V11, V12, V13, V14, V15, V16)	----- ----- ----- ----	

Description	Range	Default	Setting
<p>Local Mode <i>Indicates the relay is in Local Mode</i></p>	<p>Combination of (BO1, BO2, BO3, BO4, BO5, BO6, BO7, BO8, BO9, BO10, BO11, BO12, BO13, BO14, BO15, BO16, BO17, BO18, BO19, BO20, BO21, BO22, L1, L2, L3, L4, L5, L6, L7, L8, L9, L10, L11, L12, L13, L14, L15, L16, L17, L18, L19, L20, V1, V2, V3, V4, V5, V6, V7, V8, V9, V10, V11, V12, V13, V14, V15, V16)</p>	<p>----- ----- ----- ----</p>	
<p>Remote Mode <i>Indicates the relay is in Remote Mode</i></p>	<p>Combination of (BO1, BO2, BO3, BO4, BO5, BO6, BO7, BO8, BO9, BO10, BO11, BO12, BO13, BO14, BO15, BO16, BO17, BO18, BO19, BO20, BO21, BO22, L1, L2, L3, L4, L5, L6, L7, L8, L9, L10, L11, L12, L13, L14, L15, L16, L17, L18, L19, L20, V1, V2, V3, V4, V5, V6, V7, V8, V9, V10, V11, V12, V13, V14, V15, V16)</p>	<p>----- ----- ----- ----</p>	
<p>BI 1 Operated <i>DC Binary Input 1 has operated</i></p>	<p>Combination of (BO1, BO2, BO3, BO4, BO5, BO6, BO7, BO8, BO9, BO10, BO11, BO12, BO13, BO14, BO15, BO16, BO17, BO18, BO19, BO20, BO21, BO22, L1, L2, L3, L4, L5, L6, L7, L8, L9, L10, L11, L12, L13, L14, L15, L16, L17, L18, L19, L20, V1, V2, V3, V4, V5, V6, V7, V8, V9, V10, V11, V12, V13, V14, V15, V16)</p>	<p>----- ----- ----- ----</p>	
<p>BI 2 Operated <i>DC Binary Input 2 has operated</i></p>	<p>Combination of (BO1, BO2, BO3, BO4, BO5, BO6, BO7, BO8, BO9, BO10, BO11, BO12, BO13, BO14, BO15, BO16, BO17, BO18, BO19, BO20, BO21, BO22, L1, L2, L3, L4, L5, L6, L7, L8, L9, L10, L11, L12, L13, L14, L15, L16, L17, L18, L19, L20, V1, V2, V3, V4, V5, V6, V7, V8, V9, V10, V11, V12, V13, V14, V15, V16)</p>	<p>----- ----- ----- ----</p>	
<p>BI 3 Operated <i>DC Binary Input 3 has operated</i></p>	<p>Combination of (BO1, BO2, BO3, BO4, BO5, BO6, BO7, BO8, BO9, BO10, BO11, BO12, BO13, BO14, BO15, BO16, BO17, BO18, BO19, BO20, BO21, BO22, L1, L2, L3, L4, L5, L6, L7, L8, L9, L10, L11, L12, L13, L14, L15, L16, L17, L18, L19, L20, V1, V2, V3, V4, V5, V6, V7, V8, V9, V10, V11, V12, V13, V14, V15, V16)</p>	<p>----- ----- ----- ----</p>	

Description	Range	Default	Setting
BI 4 Operated <i>DC Binary Input 4 has operated</i>	Combination of (BO1, BO2, BO3, BO4, BO5, BO6, BO7, BO8, BO9, BO10, BO11, BO12, BO13, BO14, BO15, BO16, BO17, BO18, BO19, BO20, BO21, BO22, L1, L2, L3, L4, L5, L6, L7, L8, L9, L10, L11, L12, L13, L14, L15, L16, L17, L18, L19, L20, V1, V2, V3, V4, V5, V6, V7, V8, V9, V10, V11, V12, V13, V14, V15, V16)	----- ----- ----- ----	
BI 5 Operated <i>DC Binary Input 5 has operated</i>	Combination of (BO1, BO2, BO3, BO4, BO5, BO6, BO7, BO8, BO9, BO10, BO11, BO12, BO13, BO14, BO15, BO16, BO17, BO18, BO19, BO20, BO21, BO22, L1, L2, L3, L4, L5, L6, L7, L8, L9, L10, L11, L12, L13, L14, L15, L16, L17, L18, L19, L20, V1, V2, V3, V4, V5, V6, V7, V8, V9, V10, V11, V12, V13, V14, V15, V16)	----- ----- ----- ----	
BI 6 Operated <i>DC Binary Input 6 has operated</i>	Combination of (BO1, BO2, BO3, BO4, BO5, BO6, BO7, BO8, BO9, BO10, BO11, BO12, BO13, BO14, BO15, BO16, BO17, BO18, BO19, BO20, BO21, BO22, L1, L2, L3, L4, L5, L6, L7, L8, L9, L10, L11, L12, L13, L14, L15, L16, L17, L18, L19, L20, V1, V2, V3, V4, V5, V6, V7, V8, V9, V10, V11, V12, V13, V14, V15, V16)	----- ----- ----- ----	
BI 7 Operated <i>DC Binary Input 7 has operated</i>	Combination of (BO1, BO2, BO3, BO4, BO5, BO6, BO7, BO8, BO9, BO10, BO11, BO12, BO13, BO14, BO15, BO16, BO17, BO18, BO19, BO20, BO21, BO22, L1, L2, L3, L4, L5, L6, L7, L8, L9, L10, L11, L12, L13, L14, L15, L16, L17, L18, L19, L20, V1, V2, V3, V4, V5, V6, V7, V8, V9, V10, V11, V12, V13, V14, V15, V16)	----- ----- ----- ----	
BI 8 Operated <i>DC Binary Input 8 has operated</i>	Combination of (BO1, BO2, BO3, BO4, BO5, BO6, BO7, BO8, BO9, BO10, BO11, BO12, BO13, BO14, BO15, BO16, BO17, BO18, BO19, BO20, BO21, BO22, L1, L2, L3, L4, L5, L6, L7, L8, L9, L10, L11, L12, L13, L14, L15, L16, L17, L18, L19, L20, V1, V2, V3, V4, V5, V6, V7, V8, V9, V10, V11, V12, V13, V14, V15, V16)	----- ----- ----- ----	

Description	Range	Default	Setting
BI 9 Operated <i>DC Binary Input 9 has operated</i>	Combination of (BO1, BO2, BO3, BO4, BO5, BO6, BO7, BO8, BO9, BO10, BO11, BO12, BO13, BO14, BO15, BO16, BO17, BO18, BO19, BO20, BO21, BO22, L1, L2, L3, L4, L5, L6, L7, L8, L9, L10, L11, L12, L13, L14, L15, L16, L17, L18, L19, L20, V1, V2, V3, V4, V5, V6, V7, V8, V9, V10, V11, V12, V13, V14, V15, V16)	----- ----- ----- ----	
BI 10 Operated <i>DC Binary Input 10 has operated</i>	Combination of (BO1, BO2, BO3, BO4, BO5, BO6, BO7, BO8, BO9, BO10, BO11, BO12, BO13, BO14, BO15, BO16, BO17, BO18, BO19, BO20, BO21, BO22, L1, L2, L3, L4, L5, L6, L7, L8, L9, L10, L11, L12, L13, L14, L15, L16, L17, L18, L19, L20, V1, V2, V3, V4, V5, V6, V7, V8, V9, V10, V11, V12, V13, V14, V15, V16)	----- ----- ----- ----	
BI 11 Operated <i>DC Binary Input 11 has operated</i>	Combination of (BO1, BO2, BO3, BO4, BO5, BO6, BO7, BO8, BO9, BO10, BO11, BO12, BO13, BO14, BO15, BO16, BO17, BO18, BO19, BO20, BO21, BO22, L1, L2, L3, L4, L5, L6, L7, L8, L9, L10, L11, L12, L13, L14, L15, L16, L17, L18, L19, L20, V1, V2, V3, V4, V5, V6, V7, V8, V9, V10, V11, V12, V13, V14, V15, V16)	----- ----- ----- ----	
BI 12 Operated <i>DC Binary Input 12 has operated</i>	Combination of (BO1, BO2, BO3, BO4, BO5, BO6, BO7, BO8, BO9, BO10, BO11, BO12, BO13, BO14, BO15, BO16, BO17, BO18, BO19, BO20, BO21, BO22, L1, L2, L3, L4, L5, L6, L7, L8, L9, L10, L11, L12, L13, L14, L15, L16, L17, L18, L19, L20, V1, V2, V3, V4, V5, V6, V7, V8, V9, V10, V11, V12, V13, V14, V15, V16)	----- ----- ----- ----	
BI 13 Operated <i>DC Binary Input 13 has operated</i>	Combination of (BO1, BO2, BO3, BO4, BO5, BO6, BO7, BO8, BO9, BO10, BO11, BO12, BO13, BO14, BO15, BO16, BO17, BO18, BO19, BO20, BO21, BO22, L1, L2, L3, L4, L5, L6, L7, L8, L9, L10, L11, L12, L13, L14, L15, L16, L17, L18, L19, L20, V1, V2, V3, V4, V5, V6, V7, V8, V9, V10, V11, V12, V13, V14, V15, V16)	----- ----- ----- ----	

Description	Range	Default	Setting
BI 14 Operated <i>DC Binary Input 14 has operated</i>	Combination of (BO1, BO2, BO3, BO4, BO5, BO6, BO7, BO8, BO9, BO10, BO11, BO12, BO13, BO14, BO15, BO16, BO17, BO18, BO19, BO20, BO21, BO22, L1, L2, L3, L4, L5, L6, L7, L8, L9, L10, L11, L12, L13, L14, L15, L16, L17, L18, L19, L20, V1, V2, V3, V4, V5, V6, V7, V8, V9, V10, V11, V12, V13, V14, V15, V16)	----- ----- ----- ---	
BI 15 Operated <i>DC Binary Input 15 has operated</i>	Combination of (BO1, BO2, BO3, BO4, BO5, BO6, BO7, BO8, BO9, BO10, BO11, BO12, BO13, BO14, BO15, BO16, BO17, BO18, BO19, BO20, BO21, BO22, L1, L2, L3, L4, L5, L6, L7, L8, L9, L10, L11, L12, L13, L14, L15, L16, L17, L18, L19, L20, V1, V2, V3, V4, V5, V6, V7, V8, V9, V10, V11, V12, V13, V14, V15, V16)	----- ----- ----- ---	
BI 16 Operated <i>DC Binary Input 16 has operated</i>	Combination of (BO1, BO2, BO3, BO4, BO5, BO6, BO7, BO8, BO9, BO10, BO11, BO12, BO13, BO14, BO15, BO16, BO17, BO18, BO19, BO20, BO21, BO22, L1, L2, L3, L4, L5, L6, L7, L8, L9, L10, L11, L12, L13, L14, L15, L16, L17, L18, L19, L20, V1, V2, V3, V4, V5, V6, V7, V8, V9, V10, V11, V12, V13, V14, V15, V16)	----- ----- ----- ---	
BI 17 Operated <i>DC Binary Input 17 has operated</i>	Combination of (BO1, BO2, BO3, BO4, BO5, BO6, BO7, BO8, BO9, BO10, BO11, BO12, BO13, BO14, BO15, BO16, BO17, BO18, BO19, BO20, BO21, BO22, L1, L2, L3, L4, L5, L6, L7, L8, L9, L10, L11, L12, L13, L14, L15, L16, L17, L18, L19, L20, V1, V2, V3, V4, V5, V6, V7, V8, V9, V10, V11, V12, V13, V14, V15, V16)	----- ----- ----- ---	
BI 18 Operated <i>DC Binary Input 18 has operated</i>	Combination of (BO1, BO2, BO3, BO4, BO5, BO6, BO7, BO8, BO9, BO10, BO11, BO12, BO13, BO14, BO15, BO16, BO17, BO18, BO19, BO20, BO21, BO22, L1, L2, L3, L4, L5, L6, L7, L8, L9, L10, L11, L12, L13, L14, L15, L16, L17, L18, L19, L20, V1, V2, V3, V4, V5, V6, V7, V8, V9, V10, V11, V12, V13, V14, V15, V16)	----- ----- ----- ---	

Description	Range	Default	Setting
BI 19 Operated <i>DC Binary Input 19 has operated</i>	Combination of (BO1, BO2, BO3, BO4, BO5, BO6, BO7, BO8, BO9, BO10, BO11, BO12, BO13, BO14, BO15, BO16, BO17, BO18, BO19, BO20, BO21, BO22, L1, L2, L3, L4, L5, L6, L7, L8, L9, L10, L11, L12, L13, L14, L15, L16, L17, L18, L19, L20, V1, V2, V3, V4, V5, V6, V7, V8, V9, V10, V11, V12, V13, V14, V15, V16)	----- ----- ----- ---	
BI 20 Operated <i>DC Binary Input 20 has operated</i>	Combination of (BO1, BO2, BO3, BO4, BO5, BO6, BO7, BO8, BO9, BO10, BO11, BO12, BO13, BO14, BO15, BO16, BO17, BO18, BO19, BO20, BO21, BO22, L1, L2, L3, L4, L5, L6, L7, L8, L9, L10, L11, L12, L13, L14, L15, L16, L17, L18, L19, L20, V1, V2, V3, V4, V5, V6, V7, V8, V9, V10, V11, V12, V13, V14, V15, V16)	----- ----- ----- ---	
BI 21 Operated <i>DC Binary Input 21 has operated</i>	Combination of (BO1, BO2, BO3, BO4, BO5, BO6, BO7, BO8, BO9, BO10, BO11, BO12, BO13, BO14, BO15, BO16, BO17, BO18, BO19, BO20, BO21, BO22, L1, L2, L3, L4, L5, L6, L7, L8, L9, L10, L11, L12, L13, L14, L15, L16, L17, L18, L19, L20, V1, V2, V3, V4, V5, V6, V7, V8, V9, V10, V11, V12, V13, V14, V15, V16)	----- ----- ----- ---	
BI 22 Operated <i>DC Binary Input 22 has operated</i>	Combination of (BO1, BO2, BO3, BO4, BO5, BO6, BO7, BO8, BO9, BO10, BO11, BO12, BO13, BO14, BO15, BO16, BO17, BO18, BO19, BO20, BO21, BO22, L1, L2, L3, L4, L5, L6, L7, L8, L9, L10, L11, L12, L13, L14, L15, L16, L17, L18, L19, L20, V1, V2, V3, V4, V5, V6, V7, V8, V9, V10, V11, V12, V13, V14, V15, V16)	----- ----- ----- ---	
BI 23 Operated <i>DC Binary Input 23 has operated</i>	Combination of (BO1, BO2, BO3, BO4, BO5, BO6, BO7, BO8, BO9, BO10, BO11, BO12, BO13, BO14, BO15, BO16, BO17, BO18, BO19, BO20, BO21, BO22, L1, L2, L3, L4, L5, L6, L7, L8, L9, L10, L11, L12, L13, L14, L15, L16, L17, L18, L19, L20, V1, V2, V3, V4, V5, V6, V7, V8, V9, V10, V11, V12, V13, V14, V15, V16)	----- ----- ----- ---	

Description	Range	Default	Setting
E1 <i>Quick Logic equation 1 operated</i>	Combination of (BO1, BO2, BO3, BO4, BO5, BO6, BO7, BO8, BO9, BO10, BO11, BO12, BO13, BO14, BO15, BO16, BO17, BO18, BO19, BO20, BO21, BO22, L1, L2, L3, L4, L5, L6, L7, L8, L9, L10, L11, L12, L13, L14, L15, L16, L17, L18, L19, L20, V1, V2, V3, V4, V5, V6, V7, V8, V9, V10, V11, V12, V13, V14, V15, V16)	----- ----- ----- ----	
E2 <i>Quick Logic equation 2 operated</i>	Combination of (BO1, BO2, BO3, BO4, BO5, BO6, BO7, BO8, BO9, BO10, BO11, BO12, BO13, BO14, BO15, BO16, BO17, BO18, BO19, BO20, BO21, BO22, L1, L2, L3, L4, L5, L6, L7, L8, L9, L10, L11, L12, L13, L14, L15, L16, L17, L18, L19, L20, V1, V2, V3, V4, V5, V6, V7, V8, V9, V10, V11, V12, V13, V14, V15, V16)	----- ----- ----- ----	
E3 <i>Quick Logic equation 3 operated</i>	Combination of (BO1, BO2, BO3, BO4, BO5, BO6, BO7, BO8, BO9, BO10, BO11, BO12, BO13, BO14, BO15, BO16, BO17, BO18, BO19, BO20, BO21, BO22, L1, L2, L3, L4, L5, L6, L7, L8, L9, L10, L11, L12, L13, L14, L15, L16, L17, L18, L19, L20, V1, V2, V3, V4, V5, V6, V7, V8, V9, V10, V11, V12, V13, V14, V15, V16)	----- ----- ----- ----	
E4 <i>Quick Logic equation 4 operated</i>	Combination of (BO1, BO2, BO3, BO4, BO5, BO6, BO7, BO8, BO9, BO10, BO11, BO12, BO13, BO14, BO15, BO16, BO17, BO18, BO19, BO20, BO21, BO22, L1, L2, L3, L4, L5, L6, L7, L8, L9, L10, L11, L12, L13, L14, L15, L16, L17, L18, L19, L20, V1, V2, V3, V4, V5, V6, V7, V8, V9, V10, V11, V12, V13, V14, V15, V16)	----- ----- ----- ----	
E5 <i>Quick Logic equation 5 operated</i>	Combination of (BO1, BO2, BO3, BO4, BO5, BO6, BO7, BO8, BO9, BO10, BO11, BO12, BO13, BO14, BO15, BO16, BO17, BO18, BO19, BO20, BO21, BO22, L1, L2, L3, L4, L5, L6, L7, L8, L9, L10, L11, L12, L13, L14, L15, L16, L17, L18, L19, L20, V1, V2, V3, V4, V5, V6, V7, V8, V9, V10, V11, V12, V13, V14, V15, V16)	----- ----- ----- ----	

Description	Range	Default	Setting
E6 <i>Quick Logic equation 6 operated</i>	Combination of (BO1, BO2, BO3, BO4, BO5, BO6, BO7, BO8, BO9, BO10, BO11, BO12, BO13, BO14, BO15, BO16, BO17, BO18, BO19, BO20, BO21, BO22, L1, L2, L3, L4, L5, L6, L7, L8, L9, L10, L11, L12, L13, L14, L15, L16, L17, L18, L19, L20, V1, V2, V3, V4, V5, V6, V7, V8, V9, V10, V11, V12, V13, V14, V15, V16)	----- ----- ----- ----	
E7 <i>Quick Logic equation 7 operated</i>	Combination of (BO1, BO2, BO3, BO4, BO5, BO6, BO7, BO8, BO9, BO10, BO11, BO12, BO13, BO14, BO15, BO16, BO17, BO18, BO19, BO20, BO21, BO22, L1, L2, L3, L4, L5, L6, L7, L8, L9, L10, L11, L12, L13, L14, L15, L16, L17, L18, L19, L20, V1, V2, V3, V4, V5, V6, V7, V8, V9, V10, V11, V12, V13, V14, V15, V16)	----- ----- ----- ----	
E8 <i>Quick Logic equation 8 operated</i>	Combination of (BO1, BO2, BO3, BO4, BO5, BO6, BO7, BO8, BO9, BO10, BO11, BO12, BO13, BO14, BO15, BO16, BO17, BO18, BO19, BO20, BO21, BO22, L1, L2, L3, L4, L5, L6, L7, L8, L9, L10, L11, L12, L13, L14, L15, L16, L17, L18, L19, L20, V1, V2, V3, V4, V5, V6, V7, V8, V9, V10, V11, V12, V13, V14, V15, V16)	----- ----- ----- ----	
E9 <i>Quick Logic equation 9 operated</i>	Combination of (BO1, BO2, BO3, BO4, BO5, BO6, BO7, BO8, BO9, BO10, BO11, BO12, BO13, BO14, BO15, BO16, BO17, BO18, BO19, BO20, BO21, BO22, L1, L2, L3, L4, L5, L6, L7, L8, L9, L10, L11, L12, L13, L14, L15, L16, L17, L18, L19, L20, V1, V2, V3, V4, V5, V6, V7, V8, V9, V10, V11, V12, V13, V14, V15, V16)	----- ----- ----- ----	
E10 <i>Quick Logic equation 10 operated</i>	Combination of (BO1, BO2, BO3, BO4, BO5, BO6, BO7, BO8, BO9, BO10, BO11, BO12, BO13, BO14, BO15, BO16, BO17, BO18, BO19, BO20, BO21, BO22, L1, L2, L3, L4, L5, L6, L7, L8, L9, L10, L11, L12, L13, L14, L15, L16, L17, L18, L19, L20, V1, V2, V3, V4, V5, V6, V7, V8, V9, V10, V11, V12, V13, V14, V15, V16)	----- ----- ----- ----	

Description	Range	Default	Setting
E11 <i>Quick Logic equation 11 operated</i>	Combination of (BO1, BO2, BO3, BO4, BO5, BO6, BO7, BO8, BO9, BO10, BO11, BO12, BO13, BO14, BO15, BO16, BO17, BO18, BO19, BO20, BO21, BO22, L1, L2, L3, L4, L5, L6, L7, L8, L9, L10, L11, L12, L13, L14, L15, L16, L17, L18, L19, L20, V1, V2, V3, V4, V5, V6, V7, V8, V9, V10, V11, V12, V13, V14, V15, V16)	----- ----- ----- ----	
E12 <i>Quick Logic equation 12 operated</i>	Combination of (BO1, BO2, BO3, BO4, BO5, BO6, BO7, BO8, BO9, BO10, BO11, BO12, BO13, BO14, BO15, BO16, BO17, BO18, BO19, BO20, BO21, BO22, L1, L2, L3, L4, L5, L6, L7, L8, L9, L10, L11, L12, L13, L14, L15, L16, L17, L18, L19, L20, V1, V2, V3, V4, V5, V6, V7, V8, V9, V10, V11, V12, V13, V14, V15, V16)	----- ----- ----- ----	
E13 <i>Quick Logic equation 13 operated</i>	Combination of (BO1, BO2, BO3, BO4, BO5, BO6, BO7, BO8, BO9, BO10, BO11, BO12, BO13, BO14, BO15, BO16, BO17, BO18, BO19, BO20, BO21, BO22, L1, L2, L3, L4, L5, L6, L7, L8, L9, L10, L11, L12, L13, L14, L15, L16, L17, L18, L19, L20, V1, V2, V3, V4, V5, V6, V7, V8, V9, V10, V11, V12, V13, V14, V15, V16)	----- ----- ----- ----	
E14 <i>Quick Logic equation 14 operated</i>	Combination of (BO1, BO2, BO3, BO4, BO5, BO6, BO7, BO8, BO9, BO10, BO11, BO12, BO13, BO14, BO15, BO16, BO17, BO18, BO19, BO20, BO21, BO22, L1, L2, L3, L4, L5, L6, L7, L8, L9, L10, L11, L12, L13, L14, L15, L16, L17, L18, L19, L20, V1, V2, V3, V4, V5, V6, V7, V8, V9, V10, V11, V12, V13, V14, V15, V16)	----- ----- ----- ----	
E15 <i>Quick Logic equation 15 operated</i>	Combination of (BO1, BO2, BO3, BO4, BO5, BO6, BO7, BO8, BO9, BO10, BO11, BO12, BO13, BO14, BO15, BO16, BO17, BO18, BO19, BO20, BO21, BO22, L1, L2, L3, L4, L5, L6, L7, L8, L9, L10, L11, L12, L13, L14, L15, L16, L17, L18, L19, L20, V1, V2, V3, V4, V5, V6, V7, V8, V9, V10, V11, V12, V13, V14, V15, V16)	----- ----- ----- ----	

Description	Range	Default	Setting
E16 <i>Quick Logic equation 16 operated</i>	Combination of (BO1, BO2, BO3, BO4, BO5, BO6, BO7, BO8, BO9, BO10, BO11, BO12, BO13, BO14, BO15, BO16, BO17, BO18, BO19, BO20, BO21, BO22, L1, L2, L3, L4, L5, L6, L7, L8, L9, L10, L11, L12, L13, L14, L15, L16, L17, L18, L19, L20, V1, V2, V3, V4, V5, V6, V7, V8, V9, V10, V11, V12, V13, V14, V15, V16)	----- ----- ----- ---	

4.9.2. Binary Output Config

Description	Range	Default	Setting
Trip Contacts <i>The Binary Outputs selected by this setting are classed as Trip contacts. (When any of these BOs operate the Trip LED is lit, CB Fail is started, if enabled, & a Fault Record is stored)</i>	Combination of (BO1, BO2, BO3, BO4, BO5, BO6, BO7, BO8, BO9, BO10, BO11, BO12, BO13, BO14, BO15, BO16, BO17, BO18, BO19, BO20, BO21, BO22)	----- ---	
Hand Reset Outputs <i>Relays selected, as Hand Reset will remain latched until manually reset from front panel or via communications link or by removing DC Supply. By default relays are Self Resetting and will reset when the driving signal is removed.</i>	Combination of (1, 2, 3, 4, 5, 6, 7, 8, 9, 10, 11, 12, 13, 14, 15, 16, 17, 18, 19, 20, 21, 22)	----- ---	
Min Operate Time 1 <i>Minimum operate time of output relay 1 if set to self reset, if also set to be pulsed then this is the pulse width</i>	0, 0.01 ... 59, 60	0.1s	
Min Operate Time 2 <i>Minimum operate time of output relay 2 if set to self reset, if also set to be pulsed then this is the pulse width</i>	0, 0.01 ... 59, 60	0.1s	
Min Operate Time 3 <i>Minimum operate time of output relay 3 if set to self reset, if also set to be pulsed then this is the pulse width</i>	0, 0.01 ... 59, 60	0.1s	
Min Operate Time 4 <i>Minimum operate time of output relay 4 if set to self reset, if also set to be pulsed then this is the pulse width</i>	0, 0.01 ... 59, 60	0.1s	
Min Operate Time 5 <i>Minimum operate time of output relay 5 if set to self reset, if also set to be pulsed then this is the pulse width</i>	0, 0.01 ... 59, 60	0.1s	
Min Operate Time 6 <i>Minimum operate time of output relay 6 if set to self reset, if also set to be pulsed then this is the pulse width</i>	0, 0.01 ... 59, 60	0.1s	
Min Operate Time 7 <i>Minimum operate time of output relay 7 if set to self reset, if also set to be pulsed then this is the pulse width</i>	0, 0.01 ... 59, 60	0.1s	

Description	Range	Default	Setting
Min Operate Time 8 <i>Minimum operate time of output relay 8 if set to self reset, if also set to be pulsed then this is the pulse width</i>	0, 0.01 ... 59, 60	0.1s	
Min Operate Time 9 <i>Minimum operate time of output relay 9 if set to self reset, if also set to be pulsed then this is the pulse width</i>	0, 0.01 ... 59, 60	0.1s	
Min Operate Time 10 <i>Minimum operate time of output relay 10 if set to self reset, if also set to be pulsed then this is the pulse width</i>	0, 0.01 ... 59, 60	0.1s	
Min Operate Time 11 <i>Minimum operate time of output relay 11 if set to self reset, if also set to be pulsed then this is the pulse width</i>	0, 0.01 ... 59, 60	0.1s	
Min Operate Time 12 <i>Minimum operate time of output relay 12 if set to self reset, if also set to be pulsed then this is the pulse width</i>	0, 0.01 ... 59, 60	0.1s	
Min Operate Time 13 <i>Minimum operate time of output relay 13 if set to self reset, if also set to be pulsed then this is the pulse width</i>	0, 0.01 ... 59, 60	0.1s	
Min Operate Time 14 <i>Minimum operate time of output relay 14 if set to self reset, if also set to be pulsed then this is the pulse width</i>	0, 0.01 ... 59, 60	0.1s	
Min Operate Time 15 <i>Minimum operate time of output relay 15 if set to self reset, if also set to be pulsed then this is the pulse width</i>	0, 0.01 ... 59, 60	0.1s	
Min Operate Time 16 <i>Minimum operate time of output relay 16 if set to self reset, if also set to be pulsed then this is the pulse width</i>	0, 0.01 ... 59, 60	0.1s	
Min Operate Time 17 <i>Minimum operate time of output relay 17 if set to self reset, if also set to be pulsed then this is the pulse width</i>	0, 0.01 ... 59, 60	0.1s	
Min Operate Time 18 <i>Minimum operate time of output relay 18 if set to self reset, if also set to be pulsed then this is the pulse width</i>	0, 0.01 ... 59, 60	0.1s	
Min Operate Time 19 <i>Minimum operate time of output relay 19 if set to self reset, if also set to be pulsed then this is the pulse width</i>	0, 0.01 ... 59, 60	0.1s	
Min Operate Time 20 <i>Minimum operate time of output relay 20 if set to self reset, if also set to be pulsed then this is the pulse width</i>	0, 0.01 ... 59, 60	0.1s	
Min Operate Time 21 <i>Minimum operate time of output relay 21 if set to self reset, if also set to be pulsed then this is the pulse width</i>	0, 0.01 ... 59, 60	0.1s	

Description	Range	Default	Setting
Min Operate Time 22 <i>Minimum operate time of output relay 22 if set to self reset, if also set to be pulsed then this is the pulse width</i>	0, 0.01 ... 59, 60	0.1s	
Pulsed Outputs <i>Selects which outputs are pulsed. The pulse width is set by the Min Operate Time setting for each output</i>	Combination of (1, 2, 3, 4, 5, 6, 7, 8, 9, 10, 11, 12, 13, 14, 15, 16, 17, 18, 19, 20, 21, 22)	----- ----	

4.9.3. LED Config

Description	Range	Default	Setting
Self Reset LEDs <i>LEDs selected, as Self Reset will automatically reset when the driving signal is removed. By default all LEDs are Hand Reset and must be manually reset either locally via the front fascia or remotely via communications.</i>	Combination of (1, 2, 3, 4, 5, 6, 7, 8, 9, 10, 11, 12, 13, 14, 15, 16, 17, 18, 19, 20)	9, 10, 11, 12, 13, 14, 15, 16, 17, 18, 19, 20	
Green LEDs <i>Selects which LEDs will be green when driven</i>	Combination of (1, 2, 3, 4, 5, 6, 7, 8, 9, 10, 11, 12, 13, 14, 15, 16, 17, 18, 19, 20)	----- --	
Red LEDs <i>Selects which LEDs will be red when driven</i>	Combination of (1, 2, 3, 4, 5, 6, 7, 8, 9, 10, 11, 12, 13, 14, 15, 16, 17, 18, 19, 20)	1, 2, 3, 4, 5, 6, 7, 8, 9, 10, 11, 12, 13, 14, 15, 16, 17, 18, 19, 20	

4.9.4. Pickup Config

Description	Range	Default	Setting
Gn P/F Pickups <i>When any of the selected pickups operate General Pickup is driven.</i>	Combination of (51-1, 51-2, 51-3, 51-4, 50-1, 50-2, 50-3, 50-4)	51-1, 51-2, 51-3, 51-4, 50-1, 50-2, 50-3, 50-4	
Gn E/F Pickups <i>As Above</i>	Combination of (51G-1, 51G-2, 51G-3, 51G-4, 50G-1, 50G-2, 50G-3, 50G-4)	51G-1, 51G-2, 51G-3, 51G-4, 50G-1, 50G-2, 50G-3, 50G-4	
Gn SEF/REF Pickups <i>As Above</i>	Combination of (51SEF-1, 51SEF-2, 51SEF-3, 51SEF-4, 50SEF-1, 50SEF-2, 50SEF-3, 50SEF-4, 64H)	51SEF-1, 51SEF-2, 51SEF-3, 51SEF-4, 50SEF-1, 50SEF-2, 50SEF-3, 50SEF-4, 64H	
Gn Voltage Pickups <i>As Above</i>	Combination of (27/59-1, 27/59-2, 27/59-3, 27/59-4, Vx 27/59, 47-1, 47-2, 59NIT, 59NDT)	27/59-1, 27/59-2, 27/59-3, 27/59-4, Vx 27/59, 47-1, 47-2, 59NIT, 59NDT	
Gn Freq Pickups <i>As Above</i>	Combination of (81-1, 81-2, 81-3, 81-4)	81-1, 81-2, 81-3, 81-4	

Description	Range	Default	Setting
Gn Misc Pickups <i>As Above</i>	Combination of (46IT, 46DT, 37-1, 37-2)	46IT, 46DT, 37-1, 37-2	

4.10. Maintenance

4.10.1. CB Counters

Description	Range	Default	Setting
Gn CB Total Trip Count <i>Selects whether the CB Total Trip Count counter is enabled</i>	Disabled, Enabled	Disabled	
Gn CB Total Trip Count Target <i>Selects the number of CB trips allowed before CB Total Trip Count counter output operates</i>	0, 1 ... 9999, 10000	100	
Gn CB Total Trip Count Reset <i>Resets CB Total Trip Count counter</i>			
Gn CB Delta Trip Count <i>Selects whether the CB Delta Trip Count counter is enabled</i>	Disabled, Enabled	Disabled	
Gn CB Delta Trip Count Target <i>Selects the number of CB trips allowed before CB Delta Trip Count counter output operates</i>	0, 1 ... 9999, 10000	100	
Gn CB Delta Trip Count Reset <i>Resets CB Delta Trip Count counter</i>			
Gn CB Count To AR Block <i>Selects whether the CB Count To AR Block counter is enabled</i>	Disabled, Enabled	Disabled	
Gn CB Count To AR Block Target <i>Selects the number of CB trips allowed before CB Count To AR Block counter output operates. While count is above target the Autorecloser will only perform 1 x Delayed Shot and Lockout</i>	0, 1 ... 9999, 10000	100	
Gn CB Count To AR Block Reset <i>Resets CB Count To AR Block counter</i>			
Gn CB Freq Ops Count <i>Selects whether the CB Frequent Operations Counter is enabled</i>	Disabled, Enabled	Disabled	
Gn CB Freq Ops Count Target <i>Selects the number of CB trips allowed before CB Frequent Operations Counter output operates. While count is above target the Autorecloser will only perform 1 x Delayed Shot and Lockout</i>	0, 1 ... 9999, 10000	10	
Gn CB Freq Ops Count Reset <i>Resets CB Frequent Operations Counter</i>			
Gn CB LO Handle Ops <i>Selects whether the CB Lockout operations Counter is enabled</i>	Disabled, Enabled	Disabled	

Description	Range	Default	Setting
Gn CB LO Handle Ops Target <i>Selects the number of CB Lockout handle operations allowed before CB LO Handle Ops Count counter output operates</i>	0, 1 ... 9999, 10000	100	
Gn CB LO Handle Ops Reset <i>Resets CB Lockout Handle Operations Counter.</i>			

4.10.2. I²T CB Wear

Description	Range	Default	Setting
Gn I ² t Counter <i>Selects whether the I²t CB Wear monitor is enabled</i>	Disabled, Enabled	Disabled	
Gn Alarm Limit <i>Sets limit before alarm is issued</i>	10, 11 ... 99000, 100000	10MA ² s	
Gn Separation Time <i>Sets the time for CB mechanism to start moving, time before contacts start to separate</i>	0, 0.001 ... 0.199, 0.2	0.02s	
Gn Clearance Time <i>Time for CB to clear fault</i>	0, 0.001 ... 0.199, 0.2	0.04s	
Reset I ² t Count <i>Reset the CB wear count</i>			

4.10.3. Output Matrix Test

4.11. Data Storage

4.11.1. Demand/Data Log

Description	Range	Default	Setting
Data Log Period <i>Selects period between stored samples</i>	5, 6, 7, 8, 9, 10, 15, 20, 25, 30, 35, 40, 45, 50, 55, 60	5min	
Clear Data Log <i>Clear the Data Log</i>			
Gn Demand Window <i>The time window over which the Min, Max and Mean values are calculated.</i>	1, 2 ... 23, 24	24hrs	
Gn Demand Window Type <i>Method used to calculate Demand values.</i>	Fixed, Peak, Rolling	Fixed	
Gn Demand Reset <i>Reset all Demand values</i>			

4.11.2. Waveform Storage

Description	Range	Default	Setting
Gn P/F Trig Storage <i>Select which elements trigger a waveform record</i>	Combination of (51-1, 51-2, 51-3, 51-4, 50-1, 50-2, 50-3, 50-4)	51-1, 51-2, 51-3, 51-4, 50-1, 50-2, 50-3, 50-4	

Description	Range	Default	Setting
Gn E/F Trig Storage <i>As Above</i>	Combination of (51G-1, 51G-2, 51G-3, 51G-4, 50G-1, 50G-2, 50G-3, 50G-4)	51G-1, 51G-2, 51G-3, 51G-4, 50G-1, 50G-2, 50G-3, 50G-4	
Gn SEF/REF Trig Storage <i>As Above</i>	Combination of (51SEF-1, 51SEF-2, 51SEF-3, 51SEF-4, 50SEF-1, 50SEF-2, 50SEF-3, 50SEF-4, 64H)	51SEF-1, 51SEF-2, 51SEF-3, 51SEF-4, 50SEF-1, 50SEF-2, 50SEF-3, 50SEF-4, 64H	
Gn Misc Current Storage <i>As Above</i>	Combination of (46IT, 46DT, 37-1, 37-2, 49 Trip, 49 Alarm)	-----	
Gn Voltage Trig Storage <i>As Above</i>	Combination of (27/59-1, 27/59-2, 27/59-3, 27/59-4, Vx 27/59, 47-1, 47-2, 59NIT, 59NDT)	-----	
Gn Freq Trig Storage <i>As Above</i>	Combination of (81-1, 81-2, 81-3, 81-4)	----	
Pre-trigger Storage <i>Select Percentage of waveform record stored before the fault is triggered</i>	10, 20, 30, 40, 50, 60, 70, 80, 90	20%	
Record Duration <i>Select waveform record duration</i>	10 Rec x 1 Sec, 5 Rec x 2 Sec, 2 Rec x 5 Sec, 1 Rec x 10 Sec	10 Rec x 1 Sec	
Trigger Waveform <i>Trigger waveform storage</i>			
Clear Waveforms <i>Clear all stored waveform records</i>			

4.11.3. Fault Storage

Description	Range	Default	Setting
Gn Max Fault Rec Time <i>Maximum time Fault record information will be stored and classed as same fault</i>	0, 1 ... 59900, 60000	2000ms	
Clear Faults <i>Clear all stored fault records</i>			

4.11.4. Event Storage

Description	Range	Default	Setting
Clear Events <i>Clear all stored event records</i>			

4.11.5. Energy Storage

Description	Range	Default	Setting
Gn Active Exp Energy Unit	1kWh, 10kWh, 100kWh, 1MWh, 10MWh, 100MWh	10kWh	

Description	Range	Default	Setting
Gn Active Imp Energy Unit	1kWh, 10kWh, 100kWh, 1MWh, 10MWh, 100MWh	10kWh	
Gn Reactive Exp Energy Unit	1kVArh, 10kVArh, 100kVArh, 1MVArh, 10MVArh, 100MVArh	10kVArh	
Gn Reactive Imp Energy Unit	1kVArh, 10kVArh, 100kVArh, 1MVArh, 10MVArh, 100MVArh	10kVArh	

4.12. Communications

Description	Range	Default	Setting
Station Address <i>IEC 60870-5-103 Station Address</i>	0, 1 ... 65533, 65534	0	
COM1-RS485 Protocol <i>Selects protocol to use for COM1-RS485</i>	OFF, IEC60870-5-103, MODBUS-RTU, DNP3, IEC60870-5-101	IEC60870-5-103	
COM1-RS485 Baud Rate <i>Sets the communications baud rate for COM1-RS485</i>	75, 110, 150, 300, 600, 1200, 2400, 4800, 9600, 19200, 38400	19200	
COM1-RS485 Parity <i>Selects whether parity information is used</i>	NONE, ODD, EVEN	EVEN	
COM1-RS485 Mode	Local, Remote, Local Or Remote	Remote	
COM3 Protocol <i>Selects protocol to use for COM3</i>	OFF, IEC60870-5-103, MODBUS-RTU, DNP3, IEC60870-5-101	IEC60870-5-103	
COM3 Baud Rate <i>Sets the communications baud rate for COM3</i>	75, 110, 150, 300, 600, 1200, 2400, 4800, 9600, 19200, 38400, 57600, 115200	19200	
COM3 Parity <i>Selects whether parity information is used</i>	NONE, ODD, EVEN	EVEN	
COM3 Line Idle <i>Selects the communications line idle sense</i>	LIGHT OFF, LIGHT ON	LIGHT OFF	
COM3 Data Echo <i>Enables echoing of data from RX port to TX port when operating relays in a Fibre Optic ring configuration</i>	OFF, ON	OFF	
COM3 Mode	Local, Remote, Local Or Remote	Remote	
COM4 Protocol <i>Selects protocol to use for COM4</i>	OFF, IEC60870-5-103, MODBUS-RTU, DNP3, IEC60870-5-101	OFF	
COM4 Baud Rate <i>Sets the communications baud rate for COM4</i>	75, 110, 150, 300, 600, 1200, 2400, 4800, 9600, 19200, 38400	19200	
COM4 Parity <i>Selects whether parity information is used</i>	NONE, ODD, EVEN	EVEN	
COM4 Line Idle <i>Selects the communications line idle sense</i>	LIGHT OFF, LIGHT ON	LIGHT OFF	

Description	Range	Default	Setting
COM4 Data Echo <i>Enables echoing of data from RX port to TX port when operating relays in a Fibre Optic ring configuration</i>	OFF, ON	OFF	
COM4 Mode	Local, Remote, Local Or Remote	Remote	
DNP3 Unsolicited Events <i>Allows unsolicited event support in the relay. When Enabled, unsolicited event transmission can be controlled by the Master. When Disabled, Master requests are ignored.</i>	Disabled, Enabled	Disabled	
DNP3 Destination Address <i>The address of the master to which unsolicited events will be sent.</i>	0, 1 ... 65533, 65534	0	
DNP3 Application Timeout	5, 6 ... 299, 300	10s	
I101 Link Mode	Balanced, Unbalanced	Unbalanced	
I101 Link Address	Not Present, 1 Octet , 2 Octets	1 Octet	
I101 Common Address of Asdu	1 Octet , 2 Octets	2 Octets	
I101 Cause of Trans. (COT)	1 Octet , 2 Octets	1 Octet	
I101 Info. Obj. Add. (IOA)	1 Octet , 2 Octets, 3 Octets	2 Octets	
I101 Asdu Address	0, 1 ... 65534, 65535	3	
I101 Cyclic Period	Off, 1 ... 3599, 3600	60s	
I101 Background Period	Off, 1 ... 1499, 1500	Off	

5. Relay Settings – Standard Plus Single/Triple

5.1. System Config

Description	Range	Default	Setting
Language Setting <i>Selects the language in which the relay text will be displayed.</i>	English, USA-English	English	
Active Group <i>Selects which settings group is currently activated</i>			
System Frequency <i>Selects the Power System Frequency from 50 or 60 Hz</i>	50, 60	50Hz	
View/Edit Group <i>Selects which settings group is currently being displayed</i>			
Setting Dependencies <i>When enabled only active settings are displayed and all others hidden</i>	Disabled, Enabled	Enabled	
Favourite Meters Timer <i>Selects the time delay after which, if no key presses have been detected, the relay will begin to poll through any screens which have been selected as favourite instruments</i>	Off, 1, 2, 5, 10, 15, 30, 60	60min	
Backlight timer <i>Controls when the LCD backlight turns off</i>	Off, 1, 2, 5, 10, 15, 30, 60	5min	
Date <i>Sets the date, this setting can only be changed on the fascia or via Relay->Control->Set Time and Date</i>			
Time <i>Sets the time, this setting can only be changed on the fascia or via Relay->Control->Set Time and Date</i>			
Curr Set Display <i>Select whether the Pickup values are shown in terms of x Nominal, Primary or Secondary values on the Relay Fascia</i>	xNom, Primary, Secondary	xNom	
E/F Curr Set Display <i>As Above</i>	xNom, Primary, Secondary	xNom	
Export Power/Lag VAR <i>Selects the signs required for exporting power and lagging VARs</i>	+ve/+ve, +ve/-ve, -ve/+ve, -ve/-ve	+ve/+ve	
Select Grp Mode <i>Mode of operation of the group change from status input. Edge triggered ignores the status input once it has changed to the relevant group, where as with Level triggered the relay will only stay in the group it has changed to whilst the status input is being driven, after which it returns to the previous group.</i>	Edge triggered, Level triggered	Edge triggered	

Description	Range	Default	Setting
<p>Clock Sync. From BI</p> <p><i>Real time clock may be synchronised using a binary input (See Clock Sync. in Binary Input Menu)</i></p>	Disabled, Seconds, Minutes	Minutes	
<p>Operating Mode</p> <p><i>Selects the current operating mode of the relay. This can also be changed by a binary input mode selection.</i></p>	Out Of Service, Local, Remote, Local Or Remote	Local Or Remote	
<p>Setting Password</p> <p><i>Allows a 4 character alpha code to be entered as the password. Note that the display shows a password dependant encrypted code on the second line of the display</i></p>	(Password)	NONE	
<p>Control Password</p> <p><i>As Above</i></p>	(Password)	NONE	
<p>Trip Alert</p> <p><i>When Enabled the occurrence of a Trip will cause the relay to display the Trip Alert Screen, the only way to leave this screen is by acknowledging the trip through the TEST/RESET button on the relay fascia</i></p>	Disabled, Enabled	Enabled	
<p>General Alarm Alert</p> <p><i>When Enabled the occurrence of a General Alarm will cause the relay to display the General Alarm Screen, any relay fascia button being pressed will cancel this action and revert to the last screen being displayed prior to the alarm</i></p>	Disabled, Enabled	Enabled	
<p>Relay Identifier</p> <p><i>An alphanumeric string shown on the LCD normally used to identifier the circuit the relay is attached to or the relays purpose</i></p>	(16 Character String)	7SR224	
<p>Circuit Identifier</p> <p><i>An alphanumeric string shown on the LCD normally used to identify the circuit name or relay's purpose</i></p>	(16 Character String)		

5.2. CT/VT Config

Description	Range	Default	Setting
Phase Nom Voltage <i>Selects the nominal voltage setting Vn of the voltage input</i>	40, 40.1 ... 159.9, 160	63.5V	
Phase Voltage Trim Magnitude <i>Allows trimming of voltage magnitude, the setting value should be the voltage required to be added to get back to Phase Nom Voltage.</i>	0, 0.1 ... 19.9, 20	0V	
Phase Voltage Trim Angle <i>Allows trimming of voltage angle, the setting value is added to the current voltage angle</i>	-45, -44.9 ... 44.9, 45	0deg	
Phase Voltage Config <i>Required to allow for different types of physical VT connections.</i>	Van,Vbn,Vcn, Vab,Vbc,3V0, Va,Vb,Vc	Van,Vbn,Vcn	
Phase VT Ratio Prim <i>VT ratio Primary value, used to scale primary voltage instruments</i>	(6 Character String)	132000	
Phase VT Ratio Sec <i>VT ratio Secondary value, used to scale primary voltage instruments</i>	40, 40.5 ... 159.5, 160	110	
Vx Nom Voltage <i>Selects the nominal voltage setting Vn of the voltage input</i>	40, 40.1 ... 159.9, 160	63.5V	
Vx Voltage Trim Magnitude <i>Allows trimming of voltage magnitude, the setting value should be the voltage required to be added to get back to Vx Nom Voltage.</i>	0, 0.1 ... 19.9, 20	0V	
Vx Voltage Trim Angle <i>Allows trimming of voltage angle, the setting value is added to the current voltage angle</i>	-45, -44.9 ... 44.9, 45	0deg	
Vx VT Ratio Prim <i>VT ratio Primary value, used to scale primary voltage instruments</i>	(6 Character String)	132000	
Vx VT Ratio Sec <i>VT ratio Secondary value, used to scale primary voltage instruments</i>	40, 40.5 ... 159.5, 160	110	
Phase Current Input <i>Selects whether 1 or 5 Amp terminals are being used for phase inputs</i>	1, 5	1A	
Phase CT Ratio <i>Phase CT ratio to scale primary current instruments</i>	1:0.2, 1:0.21 ... 5000:6.9, 5000:7	2000:1	
Earth Current Input <i>Selects whether 1 or 5 Amp terminals are being used for Measured Earth inputs</i>	1, 5	1A	
Earth CT Ratio <i>Measured Earth CT ratio to scale primary current instruments</i>	1:0.2, 1:0.21 ... 5000:6.9, 5000:7	2000:1	

Description	Range	Default	Setting
I1, I2, I3 Connections <i>Allocates phase reference letters to the relay hardware current inputs</i>	ABC, ACB, BAC, BCA, CAB,CBA	ABC	
V1, V2, V3 Connections <i>Allocates phase reference letters to the relay hardware voltage inputs</i>	ABC, ACB, BAC, BCA, CAB,CBA	ABC	
Phase Rotation <i>Specifies the vectorial positive phase sequence order of the allocated phase references. This setting allows the relay to be applied on networks with abnormal phasor sequence.</i>	A,B,C A,C,B	A,B,C	

5.3. Function Config

Description	Range	Default	Setting
Gn Phase Overcurrent <i>When set to Disabled, no Phase Overcurrent elements will be functional and all associated settings will be hidden. (The Setting Dependencies setting being set to Disabled will make all settings visible but will not allow them to operate).</i>	Enabled, Disabled	Disabled	
Gn Voltage Cont O/C <i>When set to Disabled, no Voltage Cont O/C elements will be functional and all associated settings will be hidden. (The Setting Dependencies setting being set to Disabled will make all settings visible but will not allow them to operate).</i>	Enabled, Disabled	Disabled	
Gn Cold Load <i>When set to Disabled, no Cold Load elements will be functional and all associated settings will be hidden. (The Setting Dependencies setting being set to Disabled will make all settings visible but will not allow them to operate).</i>	Enabled, Disabled	Disabled	
Gn Measured E/F <i>When set to Disabled, no Measured E/F elements will be functional and all associated settings will be hidden. (The Setting Dependencies setting being set to Disabled will make all settings visible but will not allow them to operate).</i>	Enabled, Disabled	Disabled	
Gn Sensitive E/F <i>When set to Disabled, no Sensitive E/F elements will be functional and all associated settings will be hidden. (The Setting Dependencies setting being set to Disabled will make all settings visible but will not allow them to operate).</i>	Enabled, Disabled	Disabled	
Gn Restricted E/F <i>When set to Disabled, no Restricted E/F elements will be functional and all associated settings will be hidden. (The Setting Dependencies setting being set to Disabled will make all settings visible but will not allow them to operate).</i>	Enabled, Disabled	Disabled	

Description	Range	Default	Setting
Gn NPS Overcurrent <i>When set to Disabled, no NPS Overcurrent elements will be functional and all associated settings will be hidden. (The Setting Dependencies setting being set to Disabled will make all settings visible but will not allow them to operate).</i>	Enabled, Disabled	Disabled	
Gn Under Current <i>When set to Disabled, no Under Current elements will be functional and all associated settings will be hidden. (The Setting Dependencies setting being set to Disabled will make all settings visible but will not allow them to operate).</i>	Enabled, Disabled	Disabled	
Gn Thermal <i>When set to Disabled, no Thermal elements will be functional and all associated settings will be hidden. (The Setting Dependencies setting being set to Disabled will make all settings visible but will not allow them to operate).</i>	Enabled, Disabled	Disabled	
Gn Phase U/O Voltage <i>When set to Disabled, no Phase U/O Voltage elements will be functional and all associated settings will be hidden. (The Setting Dependencies setting being set to Disabled will make all settings visible but will not allow them to operate).</i>	Enabled, Disabled	Disabled	
Gn Vx U/O Voltage <i>When set to Disabled, no Vx U/O Voltage elements will be functional and all associated settings will be hidden. (The Setting Dependencies setting being set to Disabled will make all settings visible but will not allow them to operate).</i>	Enabled, Disabled	Disabled	
Gn NPS Overvoltage <i>When set to Disabled, no NPS Overvoltage elements will be functional and all associated settings will be hidden. (The Setting Dependencies setting being set to Disabled will make all settings visible but will not allow them to operate).</i>	Enabled, Disabled	Disabled	
Gn Neutral Overvoltage <i>When set to Disabled, no Neutral Overvoltage elements will be functional and all associated settings will be hidden. (The Setting Dependencies setting being set to Disabled will make all settings visible but will not allow them to operate).</i>	Enabled, Disabled	Disabled	
Gn U/O Frequency <i>When set to Disabled, no U/O Frequency elements will be functional and all associated settings will be hidden. (The Setting Dependencies setting being set to Disabled will make all settings visible but will not allow them to operate).</i>	Enabled, Disabled	Disabled	

Description	Range	Default	Setting
Gn CB Fail <i>When set to Disabled, no CB Fail elements will be functional and all associated settings will be hidden. (The Setting Dependencies setting being set to Disabled will make all settings visible but will not allow them to operate).</i>	Enabled, Disabled	Disabled	
Gn VT Supervision <i>When set to Disabled, no VT Supervision elements will be functional and all associated settings will be hidden. (The Setting Dependencies setting being set to Disabled will make all settings visible but will not allow them to operate).</i>	Enabled, Disabled	Disabled	
Gn CT Supervision <i>When set to Disabled, no CT Supervision elements will be functional and all associated settings will be hidden. (The Setting Dependencies setting being set to Disabled will make all settings visible but will not allow them to operate).</i>	Enabled, Disabled	Disabled	
Gn Broken Conductor <i>When set to Disabled, no Broken Conductor elements will be functional and all associated settings will be hidden. (The Setting Dependencies setting being set to Disabled will make all settings visible but will not allow them to operate).</i>	Enabled, Disabled	Disabled	
Gn Trip Cct Supervision <i>When set to Disabled, no Trip Cct Supervision elements will be functional and all associated settings will be hidden. (The Setting Dependencies setting being set to Disabled will make all settings visible but will not allow them to operate).</i>	Enabled, Disabled	Disabled	
Gn Inrush Detector <i>When set to Disabled, no Inrush Detector elements will be functional and all associated settings will be hidden. (The Setting Dependencies setting being set to Disabled will make all settings visible but will not allow them to operate).</i>	Enabled, Disabled	Disabled	
Gn CB Counters <i>When set to Disabled, no Gn CB Counter elements will be functional and all associated settings will be hidden. (The Setting Dependencies setting being set to Disabled will make all settings visible but will not allow them to operate).</i>	Enabled, Disabled	Disabled	
Gn I ² t CB Wear <i>When set to Disabled, no Gn I²t CB Wear elements will be functional and all associated settings will be hidden. (The Setting Dependencies setting being set to Disabled will make all settings visible but will not allow them to operate).</i>	Enabled, Disabled	Disabled	

Description	Range	Default	Setting
Gn Battery Test <i>When set to Disabled, no Battery Test elements will be functional and all associated settings will be hidden. (The Setting Dependencies setting being set to Disabled will make all settings visible but will not allow them to operate).</i>	Enabled, Disabled	Disabled	
Gn Capacitor Test <i>When set to Disabled, no Capacitor Test elements will be functional and all associated settings will be hidden. (The Setting Dependencies setting being set to Disabled will make all settings visible but will not allow them to operate).</i>	Enabled, Disabled	Disabled	
Gn 27Sag & 59Swell <i>When set to Disabled, no 27Sag & 59Swell elements will be functional and all associated settings will be hidden. (The Setting Dependencies setting being set to Disabled will make all settings visible but will not allow them to operate).</i>	Enabled, Disabled	Disabled	

5.4. Current Prot'n

5.4.1. Phase Overcurrent

Description	Range	Default	Setting
Gn 67 Char Angle <i>Maximum torque angle for phase overcurrent elements</i>	-95, -94 ... 94, 95	45deg	
Gn 67 Minimum Voltage <i>Selects the directional elements minimum voltage, below which the element will be inhibited</i>	1, 1.5 ... 19.5, 20	1V	
Gn 67 2-out-of-3 Logic <i>Selects whether 2 out of 3 voting logic is enabled for phase overcurrent elements</i>	Enabled, Disabled	Disabled	
Gn 51/50 Measurement <i>Selects whether the RMS value used by the 51 & 50 elements is True RMS or only calculated at fundamental frequency</i>	RMS, Fundamental	RMS	

5.4.1.1. 51-1

Description	Range	Default	Setting
Gn 51-1 Element <i>Selects whether the 51-1 IDMTL Overcurrent element is enabled</i>	Disabled, Enabled	Disabled	
Gn 51-1 Dir. Control <i>Selects whether 51-1 element is non-directional, forward or reverse</i>	Non-Dir, Forward, Reverse	Non-Dir	
Gn 51-1 Setting <i>Pickup level</i>	0.05, 0.06 ... 2.49, 2.5	1xIn	

Description	Range	Default	Setting
Gn 51-1 Char <i>Selects characteristic curve to be IEC or ANSI IDMTL or DTL</i>	DTL, IEC-NI ... 201, 202	IEC-NI	
Gn 51-1 Time Mult (IEC/ANSI) <i>Time multiplier (applicable to IEC and ANSI curves but not DTL selection)</i>	0.025, 0.05 ... 1.575, 1.6	1	
Gn 51-1 Delay (DTL) <i>Delay (applicable only when DTL is selected for characteristic)</i>	0, 0.01 ... 19.99, 20	5s	
Gn 51-1 Min Operate Time <i>Minimum operate time of element.</i>	0, 0.01 ... 19.99, 20	0s	
Gn 51-1 Follower DTL <i>Additional definite time added after characteristic time</i>	0, 0.01 ... 19.99, 20	0s	
Gn 51-1 Reset <i>Selects between an ANSI decaying reset characteristic or a definite time reset</i>	(ANSI) Decaying, 0 ... 59, 60	0s	
Gn 51-1 VTS Action <i>Selects whether 51-1 element is blocked or made non-directional when VTS operates</i>	Off, Inhibit, Non-Dir	Off	
Gn 51-1 Inrush Action <i>Selects if the 51-1 element is blocked from operating when 2nd Harmonic Inrush Detector operates</i>	Off, Inhibit	Off	

5.4.1.2. 51-2

Description	Range	Default	Setting
Gn 51-2 Element <i>Selects whether the 51-2 IDMTL Overcurrent element is enabled</i>	Disabled, Enabled	Disabled	
Gn 51-2 Dir. Control <i>Selects whether 51-2 element is non-directional, forward or reverse</i>	Non-Dir, Forward, Reverse	Non-Dir	
Gn 51-2 Setting <i>Pickup level</i>	0.05, 0.06 ... 2.49, 2.5	1xIn	
Gn 51-2 Char <i>Selects characteristic curve to be IEC or ANSI IDMTL or DTL</i>	DTL, IEC-NI ... 201, 202	IEC-NI	
Gn 51-2 Time Mult (IEC/ANSI) <i>Time multiplier (applicable to IEC and ANSI curves but not DTL selection)</i>	0.025, 0.05 ... 1.575, 1.6	1	
Gn 51-2 Delay (DTL) <i>Delay (applicable only when DTL is selected for characteristic)</i>	0, 0.01 ... 19.99, 20	5s	
Gn 51-2 Min Operate Time <i>Minimum operate time of element.</i>	0, 0.01 ... 19.99, 20	0s	
Gn 51-2 Follower DTL <i>Additional definite time added after characteristic time</i>	0, 0.01 ... 19.99, 20	0s	
Gn 51-2 Reset <i>Selects between an ANSI decaying reset characteristic or a definite time reset</i>	(ANSI) Decaying, 0 ... 59, 60	0s	

Description	Range	Default	Setting
Gn 51-2 VTS Action <i>Selects whether 51-2 element is blocked or made non-directional when VTS operates</i>	Off, Inhibit, Non-Dir	Off	
Gn 51-2 Inrush Action <i>Selects if the 51-2 element is blocked from operating when 2nd Harmonic Inrush Detector operates</i>	Off, Inhibit	Off	

5.4.1.3. 51-3

Description	Range	Default	Setting
Gn 51-3 Element <i>Selects whether the 51-3 IDMTL Overcurrent element is enabled</i>	Disabled, Enabled	Disabled	
Gn 51-3 Dir. Control <i>Selects whether 51-3 element is non-directional, forward or reverse</i>	Non-Dir, Forward, Reverse	Non-Dir	
Gn 51-3 Setting <i>Pickup level</i>	0.05, 0.06 ... 2.49, 2.5	1xIn	
Gn 51-3 Char <i>Selects characteristic curve to be IEC or ANSI IDMTL or DTL</i>	DTL, IEC-NI ... 201, 202	IEC-NI	
Gn 51-3 Time Mult (IEC/ANSI) <i>Time multiplier (applicable to IEC and ANSI curves but not DTL selection)</i>	0.025, 0.05 ... 1.575, 1.6	1	
Gn 51-3 Delay (DTL) <i>Delay (applicable only when DTL is selected for characteristic)</i>	0, 0.01 ... 19.99, 20	5s	
Gn 51-3 Min Operate Time <i>Minimum operate time of element.</i>	0, 0.01 ... 19.99, 20	0s	
Gn 51-3 Follower DTL <i>Additional definite time added after characteristic time</i>	0, 0.01 ... 19.99, 20	0s	
Gn 51-3 Reset <i>Selects between an ANSI decaying reset characteristic or a definite time reset</i>	(ANSI) Decaying, 0 ... 59, 60	0s	
Gn 51-3 VTS Action <i>Selects whether 51-3 element is blocked or made non-directional when VTS operates</i>	Off, Inhibit, Non-Dir	Off	
Gn 51-3 Inrush Action <i>Selects if the 51-3 element is blocked from operating when 2nd Harmonic Inrush Detector operates</i>	Off, Inhibit	Off	

5.4.1.4. 51-4

Description	Range	Default	Setting
Gn 51-4 Element <i>Selects whether the 51-4 IDMTL Overcurrent element is enabled</i>	Disabled, Enabled	Disabled	
Gn 51-4 Dir. Control <i>Selects whether 51-4 element is non-directional, forward or reverse</i>	Non-Dir, Forward, Reverse	Non-Dir	
Gn 51-4 Setting <i>Pickup level</i>	0.05, 0.06 ... 2.49, 2.5	1xIn	

Description	Range	Default	Setting
Gn 51-4 Char <i>Selects characteristic curve to be IEC or ANSI IDMTL or DTL</i>	DTL, IEC-NI ... 201, 202	IEC-NI	
Gn 51-4 Time Mult (IEC/ANSI) <i>Time multiplier (applicable to IEC and ANSI curves but not DTL selection)</i>	0.025, 0.05 ... 1.575, 1.6	1	
Gn 51-4 Delay (DTL) <i>Delay (applicable only when DTL is selected for characteristic)</i>	0, 0.01 ... 19.99, 20	5s	
Gn 51-4 Min Operate Time <i>Minimum operate time of element.</i>	0, 0.01 ... 19.99, 20	0s	
Gn 51-4 Follower DTL <i>Additional definite time added after characteristic time</i>	0, 0.01 ... 19.99, 20	0s	
Gn 51-4 Reset <i>Selects between an ANSI decaying reset characteristic or a definite time reset</i>	(ANSI) Decaying, 0 ... 59, 60	0s	
Gn 51-4 VTS Action <i>Selects whether 51-4 element is blocked or made non-directional when VTS operates</i>	Off, Inhibit, Non-Dir	Off	
Gn 51-4 Inrush Action <i>Selects if the 51-4 element is blocked from operating when 2nd Harmonic Inrush Detector operates</i>	Off, Inhibit	Off	

5.4.1.5. 50-1

Description	Range	Default	Setting
Gn 50-1 Element <i>Selects whether the INST/ DTL Overcurrent element is enabled</i>	Disabled, Enabled	Disabled	
Gn 50-1 Dir. Control <i>Selects whether 50-1 element is non-directional, forward or reverse</i>	Non-Dir, Forward, Reverse	Non-Dir	
Gn 50-1 Setting <i>Pickup level</i>	0.05, 0.06 ... 49.5, 50	1xIn	
Gn 50-1 Delay <i>Sets operate delay time</i>	0, 0.01 ... 14300, 14400	0s	
Gn 50-1 VTS Action <i>Selects whether 50-1 element is blocked or made non-directional when VTS operates</i>	Off, Inhibit, Non-Dir	Off	
Gn 50-1 Inrush Action <i>Selects if the 50-1 element is blocked from operating when 2nd Harmonic Inrush Detector operates</i>	Off, Inhibit	Off	

5.4.1.6. 50-2

Description	Range	Default	Setting
Gn 50-2 Element <i>Selects whether the INST/ DTL Overcurrent element is enabled</i>	Disabled, Enabled	Disabled	
Gn 50-2 Dir. Control <i>Selects whether 50-2 element is non-directional, forward or reverse</i>	Non-Dir, Forward, Reverse	Non-Dir	

Description	Range	Default	Setting
Gn 50-2 Setting <i>Pickup level</i>	0.05, 0.06 ... 49.5, 50	1xIn	
Gn 50-2 Delay <i>Sets operate delay time</i>	0, 0.01 ... 14300, 14400	0s	
Gn 50-2 VTS Action <i>Selects whether 50-2 element is blocked or made non-directional when VTS operates</i>	Off, Inhibit, Non-Dir	Off	
Gn 50-2 Inrush Action <i>Selects if the 50-2 element is blocked from operating when 2nd Harmonic Inrush Detector operates</i>	Off, Inhibit	Off	

5.4.1.7. 50-3

Description	Range	Default	Setting
Gn 50-3 Element <i>Selects whether the INST/ DTL Overcurrent element is enabled</i>	Disabled, Enabled	Disabled	
Gn 50-3 Dir. Control <i>Selects whether 50-3 element is non-directional, forward or reverse</i>	Non-Dir, Forward, Reverse	Non-Dir	
Gn 50-3 Setting <i>Pickup level</i>	0.05, 0.06 ... 49.5, 50	1xIn	
Gn 50-3 Delay <i>Sets operate delay time</i>	0, 0.01 ... 14300, 14400	0s	
Gn 50-3 VTS Action <i>Selects whether 50-3 element is blocked or made non-directional when VTS operates</i>	Off, Inhibit, Non-Dir	Off	
Gn 50-3 Inrush Action <i>Selects if the 50-3 element is blocked from operating when 2nd Harmonic Inrush Detector operates</i>	Off, Inhibit	Off	

5.4.1.8. 50-4

Description	Range	Default	Setting
Gn 50-4 Element <i>Selects whether the INST/ DTL Overcurrent element is enabled</i>	Disabled, Enabled	Disabled	
Gn 50-4 Dir. Control <i>Selects whether 50-4 element is non-directional, forward or reverse</i>	Non-Dir, Forward, Reverse	Non-Dir	
Gn 50-4 Setting <i>Pickup level</i>	0.05, 0.06 ... 49.5, 50	1xIn	
Gn 50-4 Delay <i>Sets operate delay time</i>	0, 0.01 ... 14300, 14400	0s	
Gn 50-4 VTS Action <i>Selects whether 50-4 element is blocked or made non-directional when VTS operates</i>	Off, Inhibit, Non-Dir	Off	
Gn 50-4 Inrush Action <i>Selects if the 50-4 element is blocked from operating when 2nd Harmonic Inrush Detector operates</i>	Off, Inhibit	Off	

5.4.2. Voltage Cont O/C

Description	Range	Default	Setting
Gn 51V Element <i>Selects whether the Voltage Controlled Overcurrent element is enabled</i>	Disabled, Enabled	Disabled	
Gn 51V Setting <i>The voltage below which 51V operates</i>	5, 5.5 ... 199.5, 200	30V	
Gn 51V VTS Action <i>Selects whether or not the 51V element is blocked when VTS operates</i>	Off, Inhibit	Off	
Gn 51-1 Multiplier <i>Multiplier applied to the 51-1 element when VCO element has operated</i>	0.25, 0.3, 0.35, 0.4, 0.45, 0.5, 0.55, 0.6, 0.65, 0.7, 0.75, 0.8, 0.85, 0.9, 0.95, 1	0.5	
Gn 51-2 Multiplier <i>Multiplier applied to the 51-2 element when VCO element has operated</i>	0.25, 0.3, 0.35, 0.4, 0.45, 0.5, 0.55, 0.6, 0.65, 0.7, 0.75, 0.8, 0.85, 0.9, 0.95, 1	0.5	
Gn 51-3 Multiplier <i>Multiplier applied to the 51-3 element when VCO element has operated</i>	0.25, 0.3, 0.35, 0.4, 0.45, 0.5, 0.55, 0.6, 0.65, 0.7, 0.75, 0.8, 0.85, 0.9, 0.95, 1	0.5	
Gn 51-4 Multiplier <i>Multiplier applied to the 51-4 element when VCO element has operated</i>	0.25, 0.3, 0.35, 0.4, 0.45, 0.5, 0.55, 0.6, 0.65, 0.7, 0.75, 0.8, 0.85, 0.9, 0.95, 1	0.5	

5.4.3. Cold Load

Description	Range	Default	Setting
Cold Load <i>Selects whether the Cold Load element is enabled</i>	Disabled, Enabled	Disabled	
Pick-up Time <i>Cold Load operate time delay</i>	1, 1.1 ... 14100, 14400	600s	
Drop-off Time <i>Cold Load reset time delay</i>	1, 1.1 ... 14100, 14400	600s	
Reduced Current <i>Selects whether reduced current functionality is to be used</i>	Disabled, Enabled	Disabled	
Reduced Current Level <i>Selects current level below which Reduced Current Time is used for Cold Load reset delay</i>	0.05, 0.1 ... 2.45, 2.5	0.25xIn	
Reduced Current Time <i>Cold Load reset time delay used when reduced current active</i>	1, 1.1 ... 14100, 14400	600s	
Gn 51c-1 Setting <i>51-1 element parameter used when Cold Load operates</i>	0.05, 0.06 ... 2.49, 2.5	1xIn	
Gn 51c-1 Char <i>As Above</i>	DTL, IEC-NI ... 201, 202	IEC-NI	
Gn 51c-1 Time Mult (IEC/ANSI) <i>As Above</i>	0.025, 0.05 ... 1.575, 1.6	1	
Gn 51c-1 Delay (DTL) <i>As Above</i>	0, 0.01 ... 19.99, 20	5s	

Description	Range	Default	Setting
Gn 51c-1 Min Operate Time <i>As Above</i>	0, 0.01 ... 19.99, 20	0s	
Gn 51c-1 Follower DTL <i>As Above</i>	0, 0.01 ... 19.99, 20	0s	
Gn 51c-1 Reset <i>As Above</i>	(ANSI) Decaying, 0 ... 59, 60	0s	
Gn 51c-2 Setting <i>51-2 element parameter used when Cold Load operates</i>	0.05, 0.06 ... 2.49, 2.5	1xIn	
Gn 51c-2 Char <i>As Above</i>	DTL, IEC-NI ... 201, 202	IEC-NI	
Gn 51c-2 Time Mult (IEC/ANSI) <i>As Above</i>	0.025, 0.05 ... 1.575, 1.6	1	
Gn 51c-2 Delay (DTL) <i>As Above</i>	0, 0.01 ... 19.99, 20	5s	
Gn 51c-2 Min Operate Time <i>As Above</i>	0, 0.01 ... 19.99, 20	0s	
Gn 51c-2 Follower DTL <i>As Above</i>	0, 0.01 ... 19.99, 20	0s	
Gn 51c-2 Reset <i>As Above</i>	(ANSI) Decaying, 0 ... 59, 60	0s	
Gn 51c-3 Setting <i>51-3 element parameter used when Cold Load operates</i>	0.05, 0.06 ... 2.49, 2.5	1xIn	
Gn 51c-3 Char <i>As Above</i>	DTL, IEC-NI ... 201, 202	IEC-NI	
Gn 51c-3 Time Mult (IEC/ANSI) <i>As Above</i>	0.025, 0.05 ... 1.575, 1.6	1	
Gn 51c-3 Delay (DTL) <i>As Above</i>	0, 0.01 ... 19.99, 20	5s	
Gn 51c-3 Min Operate Time <i>As Above</i>	0, 0.01 ... 19.99, 20	0s	
Gn 51c-3 Follower DTL <i>As Above</i>	0, 0.01 ... 19.99, 20	0s	
Gn 51c-3 Reset <i>As Above</i>	(ANSI) Decaying, 0 ... 59, 60	0s	
Gn 51c-4 Setting <i>51-4 element parameter used when Cold Load operates</i>	0.05, 0.06 ... 2.49, 2.5	1xIn	
Gn 51c-4 Char <i>As Above</i>	DTL, IEC-NI ... 201, 202	IEC-NI	
Gn 51c-4 Time Mult (IEC/ANSI) <i>As Above</i>	0.025, 0.05 ... 1.575, 1.6	1	
Gn 51c-4 Delay (DTL) <i>As Above</i>	0, 0.01 ... 19.99, 20	5s	
Gn 51c-4 Min Operate Time <i>As Above</i>	0, 0.01 ... 19.99, 20	0s	
Gn 51c-4 Follower DTL <i>As Above</i>	0, 0.01 ... 19.99, 20	0s	

Description	Range	Default	Setting
Gn 51c-4 Reset <i>As Above</i>	(ANSI) Decaying, 0 ... 59, 60	0s	

5.4.4. Measured E/F

Description	Range	Default	Setting
Gn 67G Char Angle <i>Maximum torque angle for measured earth fault elements</i>	-95, -94 ... 94, 95	-15deg	
Gn 67G Minimum Voltage <i>Selects the directional elements minimum voltage, below which the element will be inhibited</i>	0.33, 0.5, 1, 1.5, 2, 2.5, 3	0.33V	
Gn 51G/50G Measurement <i>Selects whether the RMS value used by the 51G & 50G elements is True RMS or only calculated at fundamental frequency. Calculated setting switches the current source from measured at I_4 to derived from sum of I_1-I_3</i>	RMS, Fundamental, Calculated	RMS	

5.4.4.1. 51G-1

Description	Range	Default	Setting
Gn 51G-1 Element <i>Selects whether the 51G-1 IDMTL measured Earth Fault element is enabled</i>	Disabled, Enabled	Disabled	
Gn 51G-1 Dir. Control <i>Selects whether 51G-1 element is non-directional, forward or reverse</i>	Non-Dir, Forward, Reverse	Non-Dir	
Gn 51G-1 Setting <i>Pickup level</i>	0.005, 0.006 ... 0.995, 1	0.5xIn	
Gn 51G-1 Char <i>Selects characteristic curve to be IEC or ANSI IDMTL or DTL</i>	DTL, IEC-NI ... 201, 202	IEC-NI	
Gn 51G-1 Time Mult (IEC/ANSI) <i>Time multiplier (applicable to IEC and ANSI curves but not DTL selection)</i>	0.025, 0.05 ... 1.575, 1.6	1	
Gn 51G-1 Delay (DTL) <i>Delay (applicable only when DTL is selected for characteristic)</i>	0, 0.01 ... 19.99, 20	5s	
Gn 51G-1 Min Operate Time <i>Minimum operate time of element.</i>	0, 0.01 ... 19.99, 20	0s	
Gn 51G-1 Follower DTL <i>Additional definite time added after characteristic time</i>	0, 0.01 ... 19.99, 20	0s	
Gn 51G-1 Reset <i>Selects between an ANSI decaying reset characteristic or DTL reset</i>	(ANSI) Decaying, 0 ... 59, 60	0s	
Gn 51G-1 VTS Action <i>Selects whether 51G-1 element is blocked or made non-directional when VTS operates</i>	Off, Inhibit, Non-Dir	Off	

Description	Range	Default	Setting
Gn 51G-1 Inrush Action <i>Selects if the 51G-1 element is blocked from operating when 2nd Harmonic Inrush Detector operates</i>	Off, Inhibit	Off	

5.4.4.2. 51G-2

Description	Range	Default	Setting
Gn 51G-2 Element <i>Selects whether the 51G-2 IDMTL measured Earth Fault element is enabled</i>	Disabled, Enabled	Disabled	
Gn 51G-2 Dir. Control <i>Selects whether 51G-2 element is non-directional, forward or reverse</i>	Non-Dir, Forward, Reverse	Non-Dir	
Gn 51G-2 Setting <i>Pickup level</i>	0.005, 0.006 ... 0.995, 1	0.5xIn	
Gn 51G-2 Char <i>Selects characteristic curve to be IEC or ANSI IDMTL or DTL</i>	DTL, IEC-NI ... 201, 202	IEC-NI	
Gn 51G-2 Time Mult (IEC/ANSI) <i>Time multiplier (applicable to IEC and ANSI curves but not DTL selection)</i>	0.025, 0.05 ... 1.575, 1.6	1	
Gn 51G-2 Delay (DTL) <i>Delay (applicable only when DTL is selected for characteristic)</i>	0, 0.01 ... 19.99, 20	5s	
Gn 51G-2 Min Operate Time <i>Minimum operate time of element.</i>	0, 0.01 ... 19.99, 20	0s	
Gn 51G-2 Follower DTL <i>Additional definite time added after characteristic time</i>	0, 0.01 ... 19.99, 20	0s	
Gn 51G-2 Reset <i>Selects between an ANSI decaying reset characteristic or DTL reset</i>	(ANSI) Decaying, 0 ... 59, 60	0s	
Gn 51G-2 VTS Action <i>Selects whether 51G-2 element is blocked or made non-directional when VTS operates</i>	Off, Inhibit, Non-Dir	Off	
Gn 51G-2 Inrush Action <i>Selects if the 51G-2 element is blocked from operating when 2nd Harmonic Inrush Detector operates</i>	Off, Inhibit	Off	

5.4.4.3. 51G-3

Description	Range	Default	Setting
Gn 51G-3 Element <i>Selects whether the 51G-3 IDMTL measured Earth Fault element is enabled</i>	Disabled, Enabled	Disabled	
Gn 51G-3 Dir. Control <i>Selects whether 51G-3 element is non-directional, forward or reverse</i>	Non-Dir, Forward, Reverse	Non-Dir	
Gn 51G-3 Setting <i>Pickup level</i>	0.005, 0.006 ... 0.995, 1	0.5xIn	
Gn 51G-3 Char <i>Selects characteristic curve to be IEC or ANSI IDMTL or DTL</i>	DTL, IEC-NI ... 201, 202	IEC-NI	
Gn 51G-3 Time Mult (IEC/ANSI) <i>Time multiplier (applicable to IEC and ANSI curves but not DTL selection)</i>	0.025, 0.05 ... 1.575, 1.6	1	
Gn 51G-3 Delay (DTL) <i>Delay (applicable only when DTL is selected for characteristic)</i>	0, 0.01 ... 19.99, 20	5s	
Gn 51G-3 Min Operate Time <i>Minimum operate time of element.</i>	0, 0.01 ... 19.99, 20	0s	
Gn 51G-3 Follower DTL <i>Additional definite time added after characteristic time</i>	0, 0.01 ... 19.99, 20	0s	
Gn 51G-3 Reset <i>Selects between an ANSI decaying reset characteristic or DTL reset</i>	(ANSI) Decaying, 0 ... 59, 60	0s	
Gn 51G-3 VTS Action <i>Selects whether 51G-3 element is blocked or made non-directional when VTS operates</i>	Off, Inhibit, Non-Dir	Off	
Gn 51G-3 Inrush Action <i>Selects if the 51G-3 element is blocked from operating when 2nd Harmonic Inrush Detector operates</i>	Off, Inhibit	Off	

5.4.4.4. 51G-4

Description	Range	Default	Setting
Gn 51G-4 Element <i>Selects whether the 51G-4 IDMTL measured Earth Fault element is enabled</i>	Disabled, Enabled	Disabled	
Gn 51G-4 Dir. Control <i>Selects whether 51G-4 element is non-directional, forward or reverse</i>	Non-Dir, Forward, Reverse	Non-Dir	
Gn 51G-4 Setting <i>Pickup level</i>	0.005, 0.006 ... 0.995, 1	0.5xIn	
Gn 51G-4 Char <i>Selects characteristic curve to be IEC or ANSI IDMTL or DTL</i>	DTL, IEC-NI ... 201, 202	IEC-NI	
Gn 51G-4 Time Mult (IEC/ANSI) <i>Time multiplier (applicable to IEC and ANSI curves but not DTL selection)</i>	0.025, 0.05 ... 1.575, 1.6	1	

Description	Range	Default	Setting
Gn 51G-4 Delay (DTL) <i>Delay (applicable only when DTL is selected for characteristic)</i>	0, 0.01 ... 19.99, 20	5s	
Gn 51G-4 Min Operate Time <i>Minimum operate time of element.</i>	0, 0.01 ... 19.99, 20	0s	
Gn 51G-4 Follower DTL <i>Additional definite time added after characteristic time</i>	0, 0.01 ... 19.99, 20	0s	
Gn 51G-4 Reset <i>Selects between an ANSI decaying reset characteristic or DTL reset</i>	(ANSI) Decaying, 0 ... 59, 60	0s	
Gn 51G-4 VTS Action <i>Selects whether 51G-4 element is blocked or made non-directional when VTS operates</i>	Off, Inhibit, Non-Dir	Off	
Gn 51G-4 Inrush Action <i>Selects if the 51G-4 element is blocked from operating when 2nd Harmonic Inrush Detector operates</i>	Off, Inhibit	Off	

5.4.4.5. 50G-1

Description	Range	Default	Setting
Gn 50G-1 Element <i>Selects whether the DTL measured Earth fault element is enabled</i>	Disabled, Enabled	Disabled	
Gn 50G-1 Dir. Control <i>Selects whether 50G-1 element is non-directional, forward or reverse</i>	Non-Dir, Forward, Reverse	Non-Dir	
Gn 50G-1 Setting <i>Pickup level</i>	0.005, 0.006 ... 24.95, 25	0.5xIn	
Gn 50G-1 Delay <i>Sets operate delay time</i>	0, 0.01 ... 14300, 14400	0s	
Gn 50G-1 VTS Action <i>Selects whether 50G-1 element is blocked or made non-directional when VTS operates</i>	Off, Inhibit, Non-Dir	Off	
Gn 50G-1 Inrush Action <i>Selects if the 50G-1 element is blocked from operating when 2nd Harmonic Inrush Detector operates</i>	Off, Inhibit	Off	

5.4.4.6. 50G-2

Description	Range	Default	Setting
Gn 50G-2 Element <i>Selects whether the DTL measured Earth fault element is enabled</i>	Disabled, Enabled	Disabled	
Gn 50G-2 Dir. Control <i>Selects whether 50G-2 element is non-directional, forward or reverse</i>	Non-Dir, Forward, Reverse	Non-Dir	
Gn 50G-2 Setting <i>Pickup level</i>	0.005, 0.006 ... 24.95, 25	0.5xIn	
Gn 50G-2 Delay <i>Sets operate delay time</i>	0, 0.01 ... 14300, 14400	0s	

Description	Range	Default	Setting
Gn 50G-2 VTS Action <i>Selects whether 50G-2 element is blocked or made non-directional when VTS operates</i>	Off, Inhibit, Non-Dir	Off	
Gn 50G-2 Inrush Action <i>Selects if the 50G-2 element is blocked from operating when 2nd Harmonic Inrush Detector operates</i>	Off, Inhibit	Off	

5.4.4.7. 50G-3

Description	Range	Default	Setting
Gn 50G-3 Element <i>Selects whether the DTL measured Earth fault element is enabled</i>	Disabled, Enabled	Disabled	
Gn 50G-3 Dir. Control <i>Selects whether 50G-3 element is non-directional, forward or reverse</i>	Non-Dir, Forward, Reverse	Non-Dir	
Gn 50G-3 Setting <i>Pickup level</i>	0.005, 0.006 ... 24.95, 25	0.5xIn	
Gn 50G-3 Delay <i>Sets operate delay time</i>	0, 0.01 ... 14300, 14400	0s	
Gn 50G-3 VTS Action <i>Selects whether 50G-3 element is blocked or made non-directional when VTS operates</i>	Off, Inhibit, Non-Dir	Off	
Gn 50G-3 Inrush Action <i>Selects if the 50G-3 element is blocked from operating when 2nd Harmonic Inrush Detector operates</i>	Off, Inhibit	Off	

5.4.4.8. 50G-4

Description	Range	Default	Setting
Gn 50G-4 Element <i>Selects whether the DTL measured Earth fault element is enabled</i>	Disabled, Enabled	Disabled	
Gn 50G-4 Dir. Control <i>Selects whether 50G-4 element is non-directional, forward or reverse</i>	Non-Dir, Forward, Reverse	Non-Dir	
Gn 50G-4 Setting <i>Pickup level</i>	0.005, 0.006 ... 24.95, 25	0.5xIn	
Gn 50G-4 Delay <i>Sets operate delay time</i>	0, 0.01 ... 14300, 14400	0s	
Gn 50G-4 VTS Action <i>Selects whether 50G-4 element is blocked or made non-directional when VTS operates</i>	Off, Inhibit, Non-Dir	Off	
Gn 50G-4 Inrush Action <i>Selects if the 50G-4 element is blocked from operating when 2nd Harmonic Inrush Detector operates</i>	Off, Inhibit	Off	

5.4.5. Sensitive E/F

Description	Range	Default	Setting
-------------	-------	---------	---------

Description	Range	Default	Setting
Gn 67SEF Char Angle <i>Maximum torque angle for sensitive earth fault elements</i>	-95, -94 ... 94, 95	-15deg	
Gn 67SEF Minimum Voltage <i>Selects the directional elements minimum voltage, below which the element will be inhibited</i>	0.33, 0.5 ... 66.5, 67	0.33V	
Gn 67SEF Compensated Network <i>When Enabled the directional elements boundaries are widened to +- 87.5 Degs</i>	Disabled, Enabled	Disabled	

5.4.5.1. 51SEF-1

Description	Range	Default	Setting
Gn 51SEF-1 Element <i>Selects whether the 51SEF-1 IDMTL Sensitive Earth Fault element is enabled</i>	Disabled, Enabled	Disabled	
Gn 51SEF-1 Dir. Control <i>Selects whether 51SEF-1 element is non-directional, forward or reverse</i>	Non-Dir, Forward, Reverse	Non-Dir	
Gn 51SEF-1 Setting <i>Pickup level</i>	0.005, 0.006 ... 0.995, 1	0.2xIn	
Gn 51SEF-1 Char <i>Selects characteristic curve to be IEC or ANSI IDMTL or DTL</i>	DTL, IEC-NI ... 201, 202	IEC-NI	
Gn 51SEF-1 Time Mult (IEC/ANSI) <i>Time multiplier (applicable to IEC and ANSI curves but not DTL selection)</i>	0.025, 0.05 ... 1.575, 1.6	1	
Gn 51SEF-1 Delay (DTL) <i>Delay (applicable only when DTL is selected for characteristic)</i>	0, 0.01 ... 19.99, 20	5s	
Gn 51SEF-1 Min Operate Time <i>Minimum operate time of element.</i>	0, 0.01 ... 19.99, 20	0s	
Gn 51SEF-1 Follower DTL <i>Additional definite time added after characteristic time</i>	0, 0.01 ... 19.99, 20	0s	
Gn 51SEF-1 Reset <i>Selects between an ANSI decaying reset characteristic or DTL reset</i>	(ANSI) Decaying, 0 ... 59, 60	0s	
Gn 51SEF-1 VTS Action <i>Selects whether 51SEF-1 element is blocked or made non-directional when VTS operates</i>	Off, Inhibit, Non-Dir	Off	

5.4.5.2. 51SEF-2

Description	Range	Default	Setting
Gn 51SEF-2 Element <i>Selects whether the 51SEF-2 IDMTL derived Earth Fault element is enabled</i>	Disabled, Enabled	Disabled	
Gn 51SEF-2 Dir. Control <i>Selects whether 51SEF-2 element is non-directional, forward or reverse</i>	Non-Dir, Forward, Reverse	Non-Dir	
Gn 51SEF-2 Setting <i>Pickup level</i>	0.005, 0.006 ... 0.995, 1	0.2xIn	

Description	Range	Default	Setting
Gn 51SEF-2 Char <i>Selects characteristic curve to be IEC or ANSI IDMTL or DTL</i>	DTL, IEC-NI ... 201, 202	IEC-NI	
Gn 51SEF-2 Time Mult (IEC/ANSI) <i>Time multiplier (applicable to IEC and ANSI curves but not DTL selection)</i>	0.025, 0.05 ... 1.575, 1.6	1	
Gn 51SEF-2 Delay (DTL) <i>Delay (applicable only when DTL is selected for characteristic)</i>	0, 0.01 ... 19.99, 20	5s	
Gn 51SEF-2 Min Operate Time <i>Minimum operate time of element.</i>	0, 0.01 ... 19.99, 20	0s	
Gn 51SEF-2 Follower DTL <i>Additional definite time added after characteristic time</i>	0, 0.01 ... 19.99, 20	0s	
Gn 51SEF-2 Reset <i>Selects between an ANSI decaying reset characteristic or DTL reset</i>	(ANSI) Decaying, 0 ... 59, 60	0s	
Gn 51SEF-2 VTS Action <i>Selects whether 51SEF-2 element is blocked or made non-directional when VTS operates</i>	Off, Inhibit, Non-Dir	Off	

5.4.5.3. 51SEF-3

Description	Range	Default	Setting
Gn 51SEF-3 Element <i>Selects whether the 51SEF-3 IDMTL derived Earth Fault element is enabled</i>	Disabled, Enabled	Disabled	
Gn 51SEF-3 Dir. Control <i>Selects whether 51SEF-3 element is non-directional, forward or reverse</i>	Non-Dir, Forward, Reverse	Non-Dir	
Gn 51SEF-3 Setting <i>Pickup level</i>	0.005, 0.006 ... 0.995, 1	0.2xIn	
Gn 51SEF-3 Char <i>Selects characteristic curve to be IEC or ANSI IDMTL or DTL</i>	DTL, IEC-NI ... 201, 202	IEC-NI	
Gn 51SEF-3 Time Mult (IEC/ANSI) <i>Time multiplier (applicable to IEC and ANSI curves but not DTL selection)</i>	0.025, 0.05 ... 1.575, 1.6	1	
Gn 51SEF-3 Delay (DTL) <i>Delay (applicable only when DTL is selected for characteristic)</i>	0, 0.01 ... 19.99, 20	5s	
Gn 51SEF-3 Min Operate Time <i>Minimum operate time of element.</i>	0, 0.01 ... 19.99, 20	0s	
Gn 51SEF-3 Follower DTL <i>Additional definite time added after characteristic time</i>	0, 0.01 ... 19.99, 20	0s	
Gn 51SEF-3 Reset <i>Selects between an ANSI decaying reset characteristic or a definite time reset</i>	(ANSI) Decaying, 0 ... 59, 60	0s	
Gn 51SEF-3 VTS Action <i>Selects whether 51SEF-3 element is blocked or made non-directional when VTS operates</i>	Off, Inhibit, Non-Dir	Off	

5.4.5.4. 51SEF-4

Description	Range	Default	Setting
Gn 51SEF-4 Element <i>Selects whether the 51SEF-4 IDMTL derived Earth Fault element is enabled</i>	Disabled, Enabled	Disabled	
Gn 51SEF-4 Dir. Control <i>Selects whether 51SEF-4 element is non-directional, forward or reverse</i>	Non-Dir, Forward, Reverse	Non-Dir	
Gn 51SEF-4 Setting <i>Pickup level</i>	0.005, 0.006 ... 0.995, 1	0.2xIn	
Gn 51SEF-4 Char <i>Selects characteristic curve to be IEC or ANSI IDMTL or DTL</i>	DTL, IEC-NI ... 201, 202	IEC-NI	
Gn 51SEF-4 Time Mult (IEC/ANSI) <i>Time multiplier (applicable to IEC and ANSI curves but not DTL selection)</i>	0.025, 0.05 ... 1.575, 1.6	1	
Gn 51SEF-4 Delay (DTL) <i>Delay (applicable only when DTL is selected for characteristic)</i>	0, 0.01 ... 19.99, 20	5s	
Gn 51SEF-4 Min Operate Time <i>Minimum operate time of element.</i>	0, 0.01 ... 19.99, 20	0s	
Gn 51SEF-4 Follower DTL <i>Additional definite time added after characteristic time</i>	0, 0.01 ... 19.99, 20	0s	
Gn 51SEF-4 Reset <i>Selects between an ANSI decaying reset characteristic or a definite time reset</i>	(ANSI) Decaying, 0 ... 59, 60	0s	
Gn 51SEF-4 VTS Action <i>Selects whether 51SEF-4 element is blocked or made non-directional when VTS operates</i>	Off, Inhibit, Non-Dir	Off	

5.4.5.5. 50SEF-1

Description	Range	Default	Setting
Gn 50SEF-1 Element <i>Selects whether the DTL measured Earth fault element is enabled</i>	Disabled, Enabled	Disabled	
Gn 50SEF-1 Dir. Control <i>Selects whether 50SEF-1 element is non-directional, forward or reverse</i>	Non-Dir, Forward, Reverse	Non-Dir	
Gn 50SEF-1 Setting <i>Pickup level</i>	0.005, 0.006 ... 4.995, 5	0.2xIn	
Gn 50SEF-1 Delay <i>Sets operate delay time</i>	0, 0.01 ... 14300, 14400	0s	
Gn 50SEF-1 VTS Action <i>Selects whether 50SEF-1 element is blocked or made non-directional when VTS operates</i>	Off, Inhibit, Non-Dir	Off	

5.4.5.6. 50SEF-2

Description	Range	Default	Setting
Gn 50SEF-2 Element <i>Selects whether the DTL measured Earth fault element is enabled</i>	Disabled, Enabled	Disabled	

Description	Range	Default	Setting
Gn 50SEF-2 Dir. Control <i>Selects whether 50SEF-2 element is non-directional, forward or reverse</i>	Non-Dir, Forward, Reverse	Non-Dir	
Gn 50SEF-2 Setting <i>Pickup level</i>	0.005, 0.006 ... 4.995, 5	0.2xIn	
Gn 50SEF-2 Delay <i>Sets operate delay time</i>	0, 0.01 ... 14300, 14400	0s	
Gn 50SEF-2 VTS Action <i>Selects whether 50SEF-2 element is blocked or made non-directional when VTS operates</i>	Off, Inhibit, Non-Dir	Off	

5.4.5.7. 50SEF-3

Description	Range	Default	Setting
Gn 50SEF-3 Element <i>Selects whether the DTL measured Earth fault element is enabled</i>	Disabled, Enabled	Disabled	
Gn 50SEF-3 Dir. Control <i>Selects whether 50SEF-3 element is non-directional, forward or reverse</i>	Non-Dir, Forward, Reverse	Non-Dir	
Gn 50SEF-3 Setting <i>Pickup level</i>	0.005, 0.006 ... 4.995, 5	0.2xIn	
Gn 50SEF-3 Delay <i>Sets operate delay time</i>	0, 0.01 ... 14300, 14400	0s	
Gn 50SEF-3 VTS Action <i>Selects whether 50SEF-3 element is blocked or made non-directional when VTS operates</i>	Off, Inhibit, Non-Dir	Off	

5.4.5.8. 50SEF-4

Description	Range	Default	Setting
Gn 50SEF-4 Element <i>Selects whether the DTL measured Earth fault element is enabled</i>	Disabled, Enabled	Disabled	
Gn 50SEF-4 Dir. Control <i>Selects whether 50SEF-4 element is non-directional, forward or reverse</i>	Non-Dir, Forward, Reverse	Non-Dir	
Gn 50SEF-4 Setting <i>Pickup level</i>	0.005, 0.006 ... 4.995, 5	0.2xIn	
Gn 50SEF-4 Delay <i>Sets operate delay time</i>	0, 0.01 ... 14300, 14400	0s	
Gn 50SEF-4 VTS Action <i>Selects whether 50SEF-4 element is blocked or made non-directional when VTS operates</i>	Off, Inhibit, Non-Dir	Off	

5.4.6. Restricted E/F

Description	Range	Default	Setting
Gn 64H Element <i>High impedance restricted earth fault current element</i>	Disabled, Enabled	Disabled	
Gn 64H Setting <i>Pickup level</i>	0.005, 0.006 ... 0.945, 0.95	0.2xIn	

Description	Range	Default	Setting
Gn 64H Delay <i>Sets operate delay time</i>	0, 0.01 ... 14300, 14400	0s	

5.4.7. NPS Overcurrent

5.4.7.1. 46IT

Description	Range	Default	Setting
Gn 46IT Element <i>Selects whether the 46IT IDMTL/DTL negative phase sequence current element is enabled</i>	Disabled, Enabled	Disabled	
Gn 46IT Setting <i>Pickup level</i>	0.05, 0.06 ... 2.49, 2.5	0.25xIn	
Gn 46IT Char <i>Selects characteristic curve to be IEC or ANSI IDMTL or DTL</i>	DTL, IEC-NI, IEC-VI, IEC-EI, IEC-LTI, ANSI-MI, ANSI-VI, ANSI-EI	IEC-NI	
Gn 46IT Time Mult (IEC/ANSI) <i>Time multiplier (applicable to IEC and ANSI curves but not DTL selection)</i>	0.025, 0.05 ... 1.575, 1.6	1	
Gn 46IT Delay (DTL) <i>Delay (applicable only when DTL is selected for characteristic)</i>	0, 0.01 ... 19.99, 20	5s	
Gn 46IT Reset <i>Selects between an ANSI decaying reset characteristic or a definite time reset</i>	(ANSI) Decaying, 0 ... 59, 60	0s	

5.4.7.2. 46DT

Description	Range	Default	Setting
Gn 46DT Element <i>Selects whether the 46DT INST/DTL negative sequence current element is enabled</i>	Disabled, Enabled	Disabled	
Gn 46DT Setting <i>Pickup level</i>	0.05, 0.06 ... 3.99, 4	0.1xIn	
Gn 46DT Delay <i>Sets operate delay time</i>	0, 0.01 ... 14300, 14400	0.02s	

5.4.8. Under Current

5.4.8.1. 37-1

Description	Range	Default	Setting
Gn 37-1 Element <i>Phase under current element 37-1</i>	Disabled, Enabled	Disabled	
Gn 37-1 Setting <i>Pickup level</i>	0.05, 0.1 ... 4.95, 5	0.25xIn	
Gn 37-1 Delay <i>Sets operate delay time</i>	0, 0.01 ... 14300, 14400	0s	

5.4.8.2. 37-2

Description	Range	Default	Setting
Gn 37-2 Element <i>Phase under current element 37-2</i>	Disabled, Enabled	Disabled	
Gn 37-2 Setting <i>Pickup level</i>	0.05, 0.1 ... 4.95, 5	0.25xIn	
Gn 37-2 Delay <i>Sets operate delay time</i>	0, 0.01 ... 14300, 14400	0s	

5.4.9. Thermal

Description	Range	Default	Setting
Gn 49 Thermal Overload <i>Selects whether the thermal overload protection element is enabled</i>	Disabled, Enabled	Disabled	
Gn 49 Overload Setting <i>Pickup level</i>	0.1, 0.11 ... 2.99, 3	1.05xIn	
Gn 49 Time Constant <i>Thermal time constant</i>	1, 1.5 ... 999.5, 1000	10m	
Gn 49 Capacity Alarm <i>Selects whether thermal capacity alarm enabled</i>	Disabled, 50 ... 99, 100	Disabled	
49 Reset Therm State <i>Control that allows thermal state to be manually reset</i>			

5.5. Voltage Prot'n

5.5.1. Phase U/O Voltage

Description	Range	Default	Setting
Gn Voltage Input Mode <i>Selects Ph-Ph or Ph-N voltages for U/V guard element & 27/59 elements operation.</i>	Ph-N, Ph-Ph	Ph-N	
Gn 27/59 U/V Guard Setting <i>Selects voltage level below which the guard element is applied.</i>	1, 1.5 ... 199.5, 200	5V	

5.5.1.1. 27/59-1

Description	Range	Default	Setting
Gn 27/59-1 Element <i>Selects whether the Under/Over voltage element stage 1 is enabled</i>	Disabled, Enabled	Disabled	
Gn 27/59-1 Operation <i>Selects between Undervoltage and Overvoltage pickup for this element</i>	Under, Over	Over	
Gn 27/59-1 Setting <i>Under or over voltage pickup level</i>	5, 5.5 ... 199.5, 200	80V	
Gn 27/59-1 Hysteresis <i>Sets the pickup to dropoff thresholds e.g. 3% on Overlevel picks up above pickup setting and drops off below 97% of setting, 3% on Underlevel picks up below setting and drops off above 103% of setting</i>	0, 0.1 ... 79.9, 80	3%	
Gn 27/59-1 Delay <i>Sets operate delay time</i>	0, 0.01 ... 14300, 14400	0.1s	
Gn 27/59-1 U/V Guarded <i>Selects whether U/V Guard element can block the operation of this element</i>	No, Yes	No	
Gn 27/59-1 VTS Inhibit <i>Selects whether element is blocked or not when VTS operates</i>	No, Yes	No	
Gn 27/59-1 O/P Phases <i>Selects whether element operates for any phase picked up or only when all phases are picked up</i>	Any, All	Any	

5.5.1.2. 27/59-2

Description	Range	Default	Setting
Gn 27/59-2 Element <i>Selects whether the Under/Over voltage element stage 2 is enabled</i>	Disabled, Enabled	Disabled	
Gn 27/59-2 Operation <i>Selects between Undervoltage and Overvoltage pickup for this element</i>	Under, Over	Over	
Gn 27/59-2 Setting <i>Under or over voltage pickup level</i>	5, 5.5 ... 199.5, 200	80V	
Gn 27/59-2 Hysteresis <i>Sets the pickup to dropoff thresholds e.g. 3% on Overlevel picks up above pickup setting and drops off below 97% of setting, 3% on Underlevel picks up below setting and drops off above 103% of setting</i>	0, 0.1 ... 79.9, 80	3%	
Gn 27/59-2 Delay <i>Sets operate delay time</i>	0, 0.01 ... 14300, 14400	0.1s	
Gn 27/59-2 U/V Guarded <i>Selects whether U/V Guard element can block the operation of this element</i>	No, Yes	No	
Gn 27/59-2 VTS Inhibit <i>Selects whether element is blocked or not when VTS operates</i>	No, Yes	No	

Description	Range	Default	Setting
Gn 27/59-2 O/P Phases <i>Selects whether element operates for any phase picked up or only when all phases are picked up</i>	Any, All	Any	

5.5.1.3. 27/59-3

Description	Range	Default	Setting
Gn 27/59-3 Element <i>Selects whether the Under/Over voltage element stage 3 is enabled</i>	Disabled, Enabled	Disabled	
Gn 27/59-3 Operation <i>Selects between Undervoltage and Overvoltage pickup for this element</i>	Under, Over	Under	
Gn 27/59-3 Setting <i>Under or over voltage pickup level</i>	5, 5.5 ... 199.5, 200	50V	
Gn 27/59-3 Hysteresis <i>Sets the pickup to dropoff thresholds e.g. 3% on Overlevel picks up above pickup setting and drops off below 97% of setting, 3% on Underlevel picks up below setting and drops off above 103% of setting</i>	0, 0.1 ... 79.9, 80	3%	
Gn 27/59-3 Delay <i>Sets operate delay time</i>	0, 0.01 ... 14300, 14400	0.1s	
Gn 27/59-3 U/V Guarded <i>Selects whether U/V Guard element can block the operation of this element</i>	No, Yes	Yes	
Gn 27/59-3 VTS Inhibit <i>Selects whether element is blocked or not when VTS operates</i>	No, Yes	No	
Gn 27/59-3 O/P Phases <i>Selects whether element operates for any phase picked up or only when all phases are picked up</i>	Any, All	Any	

5.5.1.4. 27/59-4

Description	Range	Default	Setting
Gn 27/59-4 Element <i>Selects whether the Under/Over voltage element stage 4 is enabled</i>	Disabled, Enabled	Disabled	
Gn 27/59-4 Operation <i>Selects between Undervoltage and Overvoltage pickup for this element</i>	Under, Over	Under	
Gn 27/59-4 Setting <i>Under or over voltage pickup level</i>	5, 5.5 ... 199.5, 200	50V	
Gn 27/59-4 Hysteresis <i>Sets the pickup to dropoff thresholds e.g. 3% on Overlevel picks up above pickup setting and drops off below 97% of setting, 3% on Underlevel picks up below setting and drops off above 103% of setting</i>	0, 0.1 ... 79.9, 80	3%	
Gn 27/59-4 Delay <i>Sets operate delay time</i>	0, 0.01 ... 14300, 14400	0.1s	

Description	Range	Default	Setting
Gn 27/59-4 U/V Guarded <i>Selects whether U/V Guard element can block the operation of this element</i>	No, Yes	Yes	
Gn 27/59-4 VTS Inhibit <i>Selects whether element is blocked or not when VTS operates</i>	No, Yes	No	
Gn 27/59-4 O/P Phases <i>Selects whether element operates for any phase picked up or only when all phases are picked up</i>	Any, All	Any	

5.5.2. Vx U/O Voltage

Description	Range	Default	Setting
Gn Vx 27/59 Element <i>Selects whether the Under/Over voltage element for Vx is enabled</i>	Disabled, Enabled	Disabled	
Gn Vx 27/59 Operation <i>Selects between Undervoltage and Overvoltage pickup for this element</i>	Under, Over	Over	
Gn Vx 27/59 Setting <i>Under or over voltage pickup level</i>	5, 5.5 ... 199.5, 200	80V	
Gn Vx 27/59 Hysteresis <i>Sets the pickup to dropoff thresholds e.g. 3% on Overlevel picks up above pickup setting and drops off below 97% of setting, 3% on Underlevel picks up below setting and drops off above 103% of setting</i>	0, 0.1 ... 79.9, 80	3%	
Gn Vx 27/59 Delay <i>Sets operate delay time</i>	0, 0.01 ... 14300, 14400	0.1s	

5.5.3. NPS Overvoltage

5.5.3.1. 47-1

Description	Range	Default	Setting
Gn 47-1 Element <i>Selects whether the definite time NPS overvoltage element is enabled</i>	Disabled, Enabled	Disabled	
Gn 47-1 Setting <i>Pickup level</i>	1, 1.5 ... 89.5, 90	20V	
Gn 47-1 Hysteresis <i>Sets the pickup to drop-off thresholds e.g. 3% picks up at setting and drops off below 97% of setting</i>	0, 0.1 ... 79.9, 80	3%	
Gn 47-1 Delay <i>Sets operate delay time</i>	0, 0.01 ... 14300, 14400	1s	

5.5.3.2. 47-2

Description	Range	Default	Setting
Gn 47-2 Element <i>Selects whether the definite time NPS overvoltage element is enabled</i>	Disabled, Enabled	Disabled	

Description	Range	Default	Setting
Gn 47-2 Setting <i>Pickup level</i>	1, 1.5 ... 89.5, 90	20V	
Gn 47-2 Hysteresis <i>Sets the pickup to drop-off thresholds e.g. 3% picks up at setting and drops off below 97% of setting</i>	0, 0.1 ... 79.9, 80	3%	
Gn 47-2 Delay <i>Sets operate delay time</i>	0, 0.01 ... 14300, 14400	0.5s	

5.5.4. Neutral Overvoltage

Description	Range	Default	Setting
Gn 59N Voltage Source <i>Selects voltage source between calculated 3V0 (Vn) or measured 3V0 through Vx input</i>	Vn, Vx	Vn	

5.5.4.1. 59NIT

Description	Range	Default	Setting
Gn 59NIT Element <i>Selects whether the inverse time neutral over voltage element is enabled</i>	Disabled, Enabled	Disabled	
Gn 59NIT Setting <i>Pickup level</i>	1, 1.5 ... 99.5, 100	5V	
Gn 59NIT Char <i>Selects characteristic curve to be IDMTL or DTL</i>	DTL, IDMTL	IDMTL	
Gn 59NIT Time Mult (IDMTL) <i>Time multiplier (applicable to IDMTL curve but not DTL selection)</i>	0.1, 0.2 ... 139.5, 140	1	
Gn 59NIT Delay (DTL) <i>Delay (applicable only when DTL is selected for characteristic)</i>	0, 0.01 ... 19.99, 20	5s	
Gn 59NIT Reset <i>Selects between an instantaneous reset characteristic or a definite time reset</i>	(ANSI) Decaying, 0 ... 59, 60	0s	

5.5.4.2. 59NDT

Description	Range	Default	Setting
Gn 59NDT Element <i>Selects whether the definite time neutral over voltage element is enabled</i>	Disabled, Enabled	Disabled	
Gn 59NDT Setting <i>Pickup level</i>	1, 1.5 ... 99.5, 100	5V	
Gn 59NDT Delay <i>Sets operate delay time</i>	0, 0.01 ... 14300, 14400	0.01s	

5.5.5. U/O Frequency

Description	Range	Default	Setting
Gn 81 U/V Guard Setting <i>Selects voltage level below which the guard element is applied.</i>	5, 5.5 ... 199.5, 200	5V	

5.5.5.1. 81-1

Description	Range	Default	Setting
Gn 81-1 Element <i>Selects whether the Under/Over frequency element stage 1 is enabled</i>	Disabled, Enabled	Disabled	
Gn 81-1 Operation <i>Selects between Underfrequency and Overfrequency pickup for this element</i>	Under, Over	Under	
Gn 81-1 Setting <i>Under or over frequency pickup level</i>	40, 40.01 ... 69.98, 69.99	49.5Hz	
Gn 81-1 Hysteresis <i>Sets the pickup to dropoff thresholds e.g. 3% on Overlevel picks up above pickup setting and drops off below 97% of setting, 3% on Underlevel picks up below setting and drops off above 103% of setting</i>	0, 0.1 ... 79.9, 80	0.1%	
Gn 81-1 Delay <i>Sets operate delay time</i>	0, 0.01 ... 14300, 14400	1s	
Gn 81-1 U/V Guarded <i>Selects whether U/V Guard element can block the operation of this element</i>	No, Yes	Yes	

5.5.5.2. 81-2

Description	Range	Default	Setting
Gn 81-2 Element <i>Selects whether the Under/Over frequency element stage 2 is enabled</i>	Disabled, Enabled	Disabled	
Gn 81-2 Operation <i>Selects between Underfrequency and Overfrequency pickup for this element</i>	Under, Over	Under	
Gn 81-2 Setting <i>Under or over frequency pickup level</i>	40, 40.01 ... 69.98, 69.99	49Hz	

Description	Range	Default	Setting
Gn 81-2 Hysteresis <i>Sets the pickup to dropoff thresholds e.g. 3% on Overlevel picks up above pickup setting and drops off below 97% of setting, 3% on Underlevel picks up below setting and drops off above 103% of setting</i>	0, 0.1 ... 79.9, 80	0.1%	
Gn 81-2 Delay <i>Sets operate delay time</i>	0, 0.01 ... 14300, 14400	0.8s	
Gn 81-2 U/V Guarded <i>Selects whether U/V Guard element can block the operation of this element</i>	No, Yes	Yes	

5.5.5.3. 81-3

Description	Range	Default	Setting
Gn 81-3 Element <i>Selects whether the Under/Over frequency element stage 3 is enabled</i>	Disabled, Enabled	Disabled	
Gn 81-3 Operation <i>Selects between Underfrequency and Overfrequency pickup for this element</i>	Under, Over	Under	
Gn 81-3 Setting <i>Under or over frequency pickup level</i>	40, 40.01 ... 69.98, 69.99	48Hz	
Gn 81-3 Hysteresis <i>Sets the pickup to dropoff thresholds e.g. 3% on Overlevel picks up above pickup setting and drops off below 97% of setting, 3% on Underlevel picks up below setting and drops off above 103% of setting</i>	0, 0.1 ... 79.9, 80	0.1%	
Gn 81-3 Delay <i>Sets operate delay time</i>	0, 0.01 ... 14300, 14400	0.6s	
Gn 81-3 U/V Guarded <i>Selects whether U/V Guard element can block the operation of this element</i>	No, Yes	Yes	

5.5.5.4. 81-4

Description	Range	Default	Setting
Gn 81-4 Element <i>Selects whether the Under/Over frequency element stage 4 is enabled</i>	Disabled, Enabled	Disabled	
Gn 81-4 Operation <i>Selects between Underfrequency and Overfrequency pickup for this element</i>	Under, Over	Under	
Gn 81-4 Setting <i>Under or over frequency pickup level</i>	40, 40.01 ... 69.98, 69.99	47.5Hz	
Gn 81-4 Hysteresis <i>Sets the pickup to dropoff thresholds e.g. 3% on Overlevel picks up above pickup setting and drops off below 97% of setting, 3% on Underlevel picks up below setting and drops off above 103% of setting</i>	0, 0.1 ... 79.9, 80	0.1%	
Gn 81-4 Delay <i>Sets operate delay time</i>	0, 0.01 ... 14300, 14400	0.4s	

Description	Range	Default	Setting
Gn 81-4 U/V Guarded <i>Selects whether U/V Guard element can block the operation of this element</i>	No, Yes	Yes	

5.6. Supervision

5.6.1. CB Fail

Description	Range	Default	Setting
Gn 50BF Element <i>Selects whether the Circuit Breaker Fail element is enabled</i>	Disabled, Enabled	Disabled	
Gn 50BF Setting <i>Breaker Fail Current Pickup level. If the current falls below this level then the CB is deemed to have opened and the element is reset.</i>	0.05, 0.055 ... 1.995, 2	0.2xIn	
Gn 50BF-I4 Setting	0.05, 0.055 ... 1.995, 2	0.05xIn	
Gn 50BF-1 Delay <i>Delay before Circuit Breaker Fail stage 1 operates</i>	0, 5 ... 59995, 60000	60ms	
Gn 50BF-2 Delay <i>Delay before Circuit Breaker Fail stage 2 operates</i>	0, 5 ... 59995, 60000	120ms	

5.6.2. VT Supervision

Description	Range	Default	Setting
Gn 60VTS Element <i>Selects whether the VT supervision element is enabled</i>	Disabled, Enabled	Disabled	
Gn 60VTS Component <i>Selects whether NPS or ZPS quantities are used by the VT supervision element</i>	NPS, ZPS	NPS	
Gn 60VTS V <i>Level above which there is a possible 1 or 2 phase VT fuse failure</i>	7, 8 ... 109, 110	7V	
Gn 60VTS I <i>Level above which a 1 or 2 phase fault condition is assumed so VTS inhibited</i>	0.05, 0.1, 0.15, 0.2, 0.25, 0.3, 0.35, 0.4, 0.45, 0.5, 0.55, 0.6, 0.65, 0.7, 0.75, 0.8, 0.85, 0.9, 0.95, 1	0.1xIn	
Gn 60VTS Vpps <i>Level below which there is a possible 3 phase VT fuse failure</i>	1, 2 ... 109, 110	15V	
Gn 60VTS Ipps Load <i>Level current must be above before 3 phase VTS will be issued</i>	0.05, 0.1, 0.15, 0.2, 0.25, 0.3, 0.35, 0.4, 0.45, 0.5, 0.55, 0.6, 0.65, 0.7, 0.75, 0.8, 0.85, 0.9, 0.95, 1	0.1xIn	
Gn 60VTS Ipps Fault <i>Level above which 3 phase fault is assumed so VTS inhibited</i>	0.05, 0.1 ... 19.95, 20	10xIn	

Description	Range	Default	Setting
Gn 60VTS Delay <i>Sets operate delay time</i>	0.03, 0.04 ... 14300, 14400	10s	

5.6.3. CT Supervision

Description	Range	Default	Setting
Gn 60CTS Element <i>Selects whether the CT supervision element is enabled (NPS current in the absence of NPS voltage)</i>	Disabled, Enabled	Disabled	
Gn 60CTS Inps <i>Arm if NPS Current (Inps) is above this level</i>	0.05, 0.1, 0.15, 0.2, 0.25, 0.3, 0.35, 0.4, 0.45, 0.5, 0.55, 0.6, 0.65, 0.7, 0.75, 0.8, 0.85, 0.9, 0.95, 1	0.1xIn	
Gn 60CTS Vnps <i>Inhibit if NPS Voltage (Vnps) is above this level</i>	7, 8 ... 109, 110	10V	
Gn 60CTS Delay <i>CTS Operate delay</i>	0.03, 0.04 ... 14300, 14400	10s	

5.6.4. Broken Conductor

Description	Range	Default	Setting
Gn 46BC Element <i>Selects whether the definite time broken conductor element is enabled</i>	Disabled, Enabled	Disabled	
Gn 46BC Setting <i>NPS Current to PPS Current ratio</i>	20, 21 ... 99, 100	20%	
Gn 46BC Delay <i>Sets operate delay time</i>	0.03, 0.04 ... 14300, 14400	20s	

5.6.5. Trip CCT Supervision

Description	Range	Default	Setting
Gn 74TCS-1 <i>Selects whether the trip circuit supervision element 74TCS-1 is enabled</i>	Disabled, Enabled	Disabled	
Gn 74TCS-1 Delay <i>Time delay before trip circuit supervision operates</i>	0, 0.02 ... 59.98, 60	0.4s	
Gn 74TCS-2 <i>Selects whether the trip circuit supervision element 74TCS-2 is enabled</i>	Disabled, Enabled	Disabled	
Gn 74TCS-2 Delay <i>Time delay before trip circuit supervision operates</i>	0, 0.02 ... 59.98, 60	0.4s	
Gn 74TCS-3 <i>Selects whether the trip circuit supervision element 74TCS-3 is enabled</i>	Disabled, Enabled	Disabled	
Gn 74TCS-3 Delay <i>Time delay before trip circuit supervision operates</i>	0, 0.02 ... 59.98, 60	0.4s	

5.6.6. Inrush Detector

Description	Range	Default	Setting
Gn 81HBL2 Element <i>Selects whether the phase inrush detector 81HBL2 is enabled</i>	Disabled, Enabled	Disabled	
Gn 81HBL2 Bias <i>Selects the bias method used for magnetising inrush. Phase – Segregated, each phase blocks itself. Cross – Blocked, each phase can block the operation of other phases. Sum - Of Squares, each phase blocks itself using the square root of the sum of squares of the 2nd harmonic.</i>	Phase, Cross, Sum	Cross	
Gn 81HBL2 Setting <i>The magnetising inrush detector operates when the 2nd harmonic current exceeds a set percentage of the fundamental current</i>	0.1, 0.11 ... 0.49, 0.5	0.2xl	

5.6.7. Battery Test

Description	Range	Default	Setting
Battery Element <i>Selects whether the Battery Element is enabled</i>	Disabled, Enabled	Disabled	
Battery Nominal Voltage <i>Selects battery nominal voltage</i>	24, 30, 48, 110, 220	48V	
Battery Test Rate <i>Frequency of battery tests</i>	Every 12 Hours, Every Day ... Every Nov 1st, Every Dec 1st	Every Month 1st	
Battery Test Time <i>Hour of the day at which test will take place</i>	0, 1 ... 22, 23	12	
Battery Test Load <i>Load resistance applied during test</i>	2.5, 2.6 ... 99.9, 100	6.8ohms	
Battery Volts Drop <i>Max step change in voltage allowed when test load is applied</i>	0.5, 0.75, 1, 1.25, 1.5, 1.75, 2, 2.25, 2.5, 2.75, 3, 3.25, 3.5	2.5V	

5.6.8. Capacitor Test

Description	Range	Default	Setting
Cap-A Element <i>Selects whether the Capacitor Element is enabled</i>	Disabled, Enabled	Disabled	
Cap-A Holdup Time <i>If capacitor test load applied for this time & capacitor is still above test threshold the load test will be classed as a pass</i>	0, 0.02 ... 9.9, 10	5s	
Cap-B Element <i>Selects whether the Capacitor Element is enabled</i>	Disabled, Enabled	Disabled	
Cap-B Holdup Time <i>If capacitor test load applied for this time & capacitor is still above test threshold the load test will be classed as a pass</i>	0, 0.02 ... 9.9, 10	5s	

Description	Range	Default	Setting
Cap-C Element <i>Selects whether the Capacitor Element is enabled</i>	Disabled, Enabled	Disabled	
Cap-C Holdup Time <i>If capacitor test load applied for this time & capacitor is still above test threshold the load test will be classed as a pass</i>	0, 0.02 ... 9.9, 10	5s	

5.6.9. Power Quality

Description	Range	Default	Setting
Gn Voltage Input Mode <i>Selects Ph-Ph or Ph-N voltages for U/V guard element & 27/59 elements operation.</i>	Ph-N, Ph-Ph	Ph-N	

5.6.10. 27SAG

Description	Range	Default	Setting
Gn 27Sag Element <i>Selects whether the 27Sag Element is enabled</i>	Disabled, Enabled	Disabled	
Gn 27Sag SARFI Threshold <i>Percentage of nominal voltage below which 27Sag SARFI is raised</i>	10, 20, 30, 40, 50, 60, 70, 80, 90	70%	
Gn 27Sag VTS Block <i>Selects whether element is blocked or not when VTS operates</i>	Disabled, Enabled	Disabled	
Gn 27Sag SIARFI Delay <i>Time below which the SIARFI count is incremented</i>	0, 0.01 ... 55, 60	0.5s	
Gn 27Sag SMARFI Delay <i>Time below which the SMARFI count is incremented, if greater than SIARFI Delay.</i>	0, 0.01 ... 55, 60	5s	
Gn 27Sag STARFI Delay <i>Time below which the STARFI count is incremented, if greater than SMARFI Delay. If voltage dip longer than this time it is classed as an interruption.</i>	0, 0.01 ... 55, 60	60s	

5.6.11. 59SWELL

Description	Range	Default	Setting
Gn 59Swell Element <i>Selects whether the 59Swell Element is enabled</i>	Disabled, Enabled	Disabled	
Gn 59Swell SARFI Threshold <i>Percentage of nominal voltage above which 59 SARFI is raised.</i>	110, 120, 130, 140	120%	
Gn 59Swell SIARFI Delay <i>Time below which the SIARFI count is incremented.</i>	0, 0.01 ... 55, 60	0.5s	
Gn 59Swell SMARFI Delay <i>Time below which the SMARFI count is incremented, if greater than SIARFI Delay</i>	0, 0.01 ... 55, 60	5s	

Description	Range	Default	Setting
Gn 59Swell STARFI Delay <i>Time below which the STARFI count is incremented, if greater than SMARFI Delay.</i>	0, 0.01 ... 55, 60	60s	

5.7. Control & Logic

5.7.1. Autoreclose Prot'n

Description	Range	Default	Setting
Gn 79 P/F Inst Trips <i>Selects which phase fault protection elements are classed as Instantaneous elements and start an autoreclose sequence. These will be blocked from operating during Delayed autoreclose sequences. See autoreclose section of manual for detail of what elements can cause only Delayed protection to be used.</i>	Combination of (51-1, 51-2, 51-3, 51-4, 50-1, 50-2, 50-3, 50-4)	-----	
Gn 79 E/F Inst Trips <i>Selects which earth fault protection elements are classed as Instantaneous elements and start an autoreclose sequence. These will be blocked from operating during Delayed autoreclose sequences. See autoreclose section of manual for detail of what elements can cause only Delayed protection to be used.</i>	Combination of (51G-1, 51G-2, 51G-3, 51G-4, 50G-1, 50G-2, 50G-3, 50G-4)	-----	
Gn 79 SEF Inst Trips <i>Selects which sensitive earth fault protection elements are classed as Instantaneous elements and start an autoreclose sequence. These will be blocked from operating during Delayed autoreclose sequences. See autoreclose section of manual for detail of what elements can cause only Delayed protection to be used.</i>	Combination of (51SEF-1, 51SEF-2, 51SEF-3, 51SEF-4, 50SEF-1, 50SEF-2, 50SEF-3, 50SEF-4)	-----	
Gn 79 P/F Delayed Trips <i>Selects which phase fault protection are classed as Delayed elements, any selected elements operating will start an autoreclose sequence.</i>	Combination of (51-1, 51-2, 51-3, 51-4, 50-1, 50-2, 50-3, 50-4)	51-1, 51-2, 51-3, 51-4, 50-1, 50-2, 50-3, 50-4	
Gn 79 E/F Delayed Trips <i>Selects which earth fault protection are classed as Delayed elements, any selected elements operating will start an autoreclose sequence.</i>	Combination of (51G-1, 51G-2, 51G-3, 51G-4, 50G-1, 50G-2, 50G-3, 50G-4)	51G-1, 51G-2, 51G-3, 51G-4, 50G-1, 50G-2, 50G-3, 50G-4	
Gn 79 SEF Delayed Trips <i>Selects which sensitive earth fault elements are classed as Delayed elements, any selected elements operating will start an autoreclose sequence.</i>	Combination of (51SEF-1, 51SEF-2, 51SEF-3, 51SEF-4, 50SEF-1, 50SEF-2, 50SEF-3, 50SEF-4)	51SEF-1, 51SEF-2, 51SEF-3, 51SEF-4, 50SEF-1, 50SEF-2, 50SEF-3, 50SEF-4	

Description	Range	Default	Setting
Gn 79 P/F HS Trips <i>Selects which phase fault elements are classed as High Set elements, any selected elements operating will start an autoreclose sequence.</i>	Combination of (50-1, 50-2, 50-3, 50-4)	----	
Gn 79 E/F HS Trips <i>Selects which earth fault elements are classed as High Set elements, any selected elements operating will start an autoreclose sequence.</i>	Combination of (50G-1, 50G-2, 50G-3, 50G-4)	----	

5.7.2. Autoreclose Config

Description	Range	Default	Setting
Gn Single Triple Mode	Mode A - 3PTrip3PLO, Mode B - 1PTrip3PLO, Mode C - 1PTrip1PLO	Mode A - 3PTrip3PLO	
Gn 79 Autoreclose <i>If disabled then all attempts to control the AR IN/OUT status will fail and the AR will be permanently Out Of Service. When enabled the AR IN/OUT state may be controlled via the CONTROL MODE menu option, via Binary Input or via local or remote communications.</i>	Disabled, Enabled	Disabled	
Gn 79 Num Shots <i>Selects the number of auto-reclose attempts before the Autorecloser locks out</i>	1, 2, 3, 4	1	
Gn 79 Retry Enable <i>Selects whether the Retry close functionality is enabled</i>	Disabled, Enabled	Disabled	
Gn 79 Retry Attempts <i>Selects the number of retries allowed per shot</i>	0, 1, 2, 3, 4, 5, 6, 7, 8, 9, 10	1	
Gn 79 Retry Interval <i>Time delay between retries</i>	0, 1 ... 599, 600	60s	
Gn 79 Reclose Blocked Delay <i>Specifies the maximum time that the Autorecloser can be blocked before proceeding to the lockout state. (NOTE: The block delay timer only starts after the Deadtime.)</i>	0, 1 ... 599, 600	60s	
Gn 79 Sequence Fail Timer <i>Time before lockout occurs on an incomplete reclose sequence. (i.e Trip & starter conditions have not been cleared after Sequence Fail Time.)</i>	0, 1 ... 599, 600	60s	
Gn 79 Minimum LO Delay <i>The time after entering lockout before any further external close commands are allowed.</i>	0, 1 ... 599, 600	2s	
Gn 79 Reset LO By Timer <i>Select whether Lockout is automatically reset after a time delay.</i>	Disabled, Enabled	Enabled	
Gn 79 Sequence Co-ord <i>Selects whether Sequence co-ordination functionality is used or not.</i>	Disabled, Enabled	Enabled	

Description	Range	Default	Setting
Gn 79 Cold Load Action <i>Selects whether whist Cold Load is active the relay will perform only Delayed Trips or not.</i>	Off, Delayed	Off	

5.7.2.1. P/F Shots

Description	Range	Default	Setting
Gn 79 P/F Prot'n Trip 1 <i>Selects whether the first phase fault trip is Instantaneous (Fast) or Delayed. When set to Delayed all P/F Inst Trips will be Inhibited for this shot.</i>	Inst, Delayed	Inst	
Gn 79 P/F Deadtime 1 <i>Time period between the fault being cleared and the close pulse being issued</i>	0.08, 0.1 ... 14300, 14400	5s	
Gn 79 P/F Prot'n Trip 2 <i>Selects whether the second phase fault trip is Instantaneous (Fast) or Delayed. When set to Delayed all P/F Inst Trips will be Inhibited for this shot.</i>	Inst, Delayed	Inst	
Gn 79 P/F Deadtime 2 <i>Time period between the fault being cleared and the close pulse being issued</i>	2, 2.1 ... 14300, 14400	5s	
Gn 79 P/F Prot'n Trip 3 <i>Selects whether the third phase fault trip is Instantaneous (Fast) or Delayed. When set to Delayed all P/F Inst Trips will be Inhibited for this shot.</i>	Inst, Delayed	Delayed	
Gn 79 P/F Deadtime 3 <i>Time period between the fault being cleared and the close pulse being issued</i>	2, 2.1 ... 14300, 14400	5s	
Gn 79 P/F Prot'n Trip 4 <i>Selects whether the fourth phase fault trip is Instantaneous (Fast) or Delayed. When set to Delayed all P/F Inst Trips will be Inhibited for this shot.</i>	Inst, Delayed	Delayed	
Gn 79 P/F Deadtime 4 <i>Time period between the fault being cleared and the close pulse being issued</i>	30, 30.1 ... 14300, 14400	30s	
Gn 79 P/F Prot'n Trip 5 <i>Selects whether the fifth phase fault trip is Instantaneous (Fast) or Delayed. When set to Delayed all P/F Inst Trips will be Inhibited for this shot.</i>	Inst, Delayed	Delayed	
Gn 79 PhA HS Trips To Lockout <i>Selects how many High Set trips are allowed before going to Lockout</i>	1, 2, 3, 4, 5	5	
Gn 79 PhB HS Trips To Lockout <i>As Above</i>	1, 2, 3, 4, 5	5	
Gn 79 PhC HS Trips To Lockout <i>As Above</i>	1, 2, 3, 4, 5	5	
Gn 79 PhA Delayed Trips To Lockout <i>Selects how many Delayed trips are allowed before going to Lockout</i>	1, 2, 3, 4, 5	5	

Description	Range	Default	Setting
Gn 79 PhB Delayed Trips To Lockout As Above	1, 2, 3, 4, 5	5	
Gn 79 PhC Delayed Trips To Lockout As Above	1, 2, 3, 4, 5	5	

5.7.2.2. E/F Shots

Description	Range	Default	Setting
Gn 79 E/F Prot'n Trip 1 <i>Selects whether the first earth fault trip is Instantaneous (Fast) or Delayed. When set to Delayed all E/F Inst Trips will be Inhibited for this shot.</i>	Inst, Delayed	Inst	
Gn 79 E/F Deadtime 1 <i>Time period between the fault being cleared and the close pulse being issued</i>	0.08, 0.1 ... 14300, 14400	5s	
Gn 79 E/F Prot'n Trip 2 <i>Selects whether the second earth fault trip is Instantaneous (Fast) or Delayed. When set to Delayed all E/F Inst Trips will be Inhibited for this shot.</i>	Inst, Delayed	Inst	
Gn 79 E/F Deadtime 2 <i>Time period between the fault being cleared and the close pulse being issued</i>	2, 2.1 ... 14300, 14400	5s	
Gn 79 E/F Prot'n Trip 3 <i>Selects whether the third earth fault trip is Instantaneous (Fast) or Delayed. When set to Delayed all E/F Inst Trips will be Inhibited for this shot.</i>	Inst, Delayed	Delayed	
Gn 79 E/F Deadtime 3 <i>Time period between the fault being cleared and the close pulse being issued</i>	2, 2.1 ... 14300, 14400	5s	
Gn 79 E/F Prot'n Trip 4 <i>Selects whether the fourth earth fault trip is Instantaneous (Fast) or Delayed. When set to Delayed all E/F Inst Trips will be Inhibited for this shot.</i>	Inst, Delayed	Delayed	
Gn 79 E/F Deadtime 4 <i>Time period between the fault being cleared and the close pulse being issued</i>	30, 30.1 ... 14300, 14400	30s	
Gn 79 E/F Prot'n Trip 5 <i>Selects whether the fifth earth fault trip is Instantaneous (Fast) or Delayed. When set to Delayed all E/F Inst Trips will be Inhibited for this shot.</i>	Inst, Delayed	Delayed	
Gn 79 E/F HS Trips To Lockout <i>Selects how many High Set trips are allowed before going to Lockout</i>	1, 2, 3, 4, 5	5	
Gn 79 E/F Delayed Trips To Lockout <i>Selects how many Delayed trips are allowed before going to Lockout</i>	1, 2, 3, 4, 5	5	

5.7.2.3. SEF Shots

Description	Range	Default	Setting
Gn 79 SEF Prot'n Trip 1 <i>Selects whether the first sensitive earth fault trip is Instantaneous or Delayed. When set to Delayed all SEF Inst Trips will be Inhibited for this shot.</i>	Inst, Delayed	Inst	
Gn 79 SEF Deadtime 1 <i>Time period between the fault being cleared and the close pulse being issued</i>	0.08, 0.1 ... 14300, 14400	5s	
Gn 79 SEF Prot'n Trip 2 <i>Selects whether the second sensitive earth fault trip is Instantaneous or Delayed. When set to Delayed all SEF Inst Trips will be Inhibited for this shot.</i>	Inst, Delayed	Inst	
Gn 79 SEF Deadtime 2 <i>Time period between the fault being cleared and the close pulse being issued</i>	2, 2.1 ... 14300, 14400	5s	
Gn 79 SEF Prot'n Trip 3 <i>Selects whether the third sensitive earth fault trip is Instantaneous or Delayed. When set to Delayed all SEF Inst Trips will be Inhibited for this shot.</i>	Inst, Delayed	Delayed	
Gn 79 SEF Deadtime 3 <i>Time period between the fault being cleared and the close pulse being issued</i>	2, 2.1 ... 14300, 14400	5s	
Gn 79 SEF Prot'n Trip 4 <i>Selects whether the fourth sensitive earth fault trip is Instantaneous or Delayed. When set to Delayed all SEF Inst Trips will be Inhibited for this shot.</i>	Inst, Delayed	Delayed	
Gn 79 SEF Deadtime 4 <i>Time period between the fault being cleared and the close pulse being issued</i>	30, 30.1 ... 14300, 14400	30s	
Gn 79 SEF Prot'n Trip 5 <i>Selects whether the fifth sensitive earth fault trip is Instantaneous or Delayed. When set to Delayed all SEF Inst Trips will be Inhibited for this shot.</i>	Inst, Delayed	Delayed	
Gn 79 SEF Delayed Trips To Lockout <i>Selects how many Delayed trips are allowed before going to Lockout</i>	1, 2, 3, 4, 5	5	

5.7.2.4. Extern Shots

Description	Range	Default	Setting
Gn 79 Extern Prot'n Trip 1 <i>Selects whether the first external trip is Instantaneous or Delayed</i>	Not Blocked, Blocked	Not Blocked	
Gn 79 Extern Deadtime 1 <i>Time period between the fault being cleared and the close pulse being issued</i>	0.08, 0.1 ... 14300, 14400	5s	
Gn 79 Extern Prot'n Trip 2 <i>Selects whether the second external trip is Instantaneous or Delayed</i>	Not Blocked, Blocked	Not Blocked	

Description	Range	Default	Setting
Gn 79 Extern Deadtime 2 <i>Time period between the fault being cleared and the close pulse being issued</i>	2, 2.1 ... 14300, 14400	5s	
Gn 79 Extern Prot'n Trip 3 <i>Selects whether the third external trip is Instantaneous or Delayed</i>	Not Blocked, Blocked	Not Blocked	
Gn 79 Extern Deadtime 3 <i>Time period between the fault being cleared and the close pulse being issued</i>	2, 2.1 ... 14300, 14400	5s	
Gn 79 Extern Prot'n Trip 4 <i>Selects whether the fourth external trip is Instantaneous or Delayed</i>	Not Blocked, Blocked	Not Blocked	
Gn 79 Extern Deadtime 4 <i>Time period between the fault being cleared and the close pulse being issued</i>	30, 30.1 ... 14300, 14400	30s	
Gn 79 Extern Prot'n Trip 5 <i>Selects whether the fifth external trip is Instantaneous or Delayed</i>	Not Blocked, Blocked	Not Blocked	
Gn 79 Extern Trips To Lockout <i>Selects how many external trips are allowed before going to Lockout</i>	1, 2, 3, 4, 5	5	

5.7.3. Manual Close

Description	Range	Default	Setting
Gn Line Check Trip <i>Selects whether line check trip is enabled, if enabled no AR sequence initiated</i>	Disabled, Enabled	Enabled	
Gn P/F Line Check Trip <i>Selects whether a phase fault line check trip is Instantaneous (Fast) or Delayed. When set to Delayed all P/F Inst Trips will be Inhibited for this shot.</i>	Inst, Delayed	Inst	
Gn E/F Line Check Trip <i>Selects whether an earth fault line check trip is Instantaneous or Delayed. When set to Delayed all E/F Inst Trips will be Inhibited for this shot.</i>	Inst, Delayed	Inst	
Gn SEF Line Check Trip <i>Selects whether a sensitive earth fault line check trip is Instantaneous or Delayed. When set to Delayed all SEF Inst Trips will be Inhibited for this shot.</i>	Inst, Delayed	Inst	
Gn Extern Line Check Trip <i>Selects whether an external line check trip is Instantaneous (Fast) or Delayed</i>	Not Blocked, Blocked	Not Blocked	

5.7.4. Circuit Breaker

Description	Range	Default	Setting
Gn Close CB Delay <i>Delay between a Close CB control being received and the Close CB contacts being operated to allow operator walk away.</i>	0, 0.1 ... 899, 900	10s	

Description	Range	Default	Setting
Gn Close CB Pulse <i>Specifies the duration of the circuit breaker close pulse</i>	0.1, 0.2 ... 59.9, 60	2s	
Gn Reclaim Timer <i>The period of time after a CB has closed and remained closed before the reclosure is deemed to be successful and the AR is re-initialised. If the CB remains open at the end of the reclaim time then the AR goes to lockout.</i>	0, 1 ... 599, 600	2s	
Gn Blocked Close Delay <i>Selects the maximum time that the manual Close CB may be blocked by interlocking before the command or control is cancelled. The relay will signal "Blocked by Interlocking".</i>	0, 1 ... 599, 600	5s	
Gn Open CB Delay <i>Delay between an Open CB control being received and the Open CB contacts being operated.</i>	0, 0.1 ... 899, 900	10s	
Gn Open CB Pulse <i>Selects the maximum time of the Open CB pulse. If the CB is not closed when this timer expires then an alarm will be raised to signify failure to close.</i>	0.1, 0.2, 0.3, 0.4, 0.5, 0.6, 0.7, 0.8, 0.9, 1, 1.1, 1.2, 1.3, 1.4, 1.5, 1.6, 1.7, 1.8, 1.9, 2	1s	
Gn CB Travel Alarm <i>Selects the maximum time that the CB should take to either Open or Close before a failure is recorded.</i>	0.01, 0.02 ... 1.99, 2	1s	
Gn PD Time Delay <i>Selects the maximum time that a CB pole discrepancy should allowed to exist before issuing an alarm. (This is not active in Mode C as single pole Lockout is allowed)</i>	1, 2 ... 14300, 14400	10s	
Gn CB Controls Latched <i>Selects whether Binary Input triggers of Close CB and Open CB are latched.</i>	Latch, Reset	Latch	

5.7.5. Quick Logic

Description	Range	Default	Setting
Quick Logic <i>Enable or Disable all logic equations</i>	Disabled, Enabled	Disabled	
E1 Equation <i>Enable or Disable logic equation E1</i>	Disabled, Enabled	Disabled	

Description	Range	Default	Setting
<p>E1</p> <p>Specify logic equations of the form $E_n = \langle \text{Operand} \rangle \langle \text{Operator} \rangle \langle \text{Operand} \rangle$ using the following: 0123456789=Digit() = Parenthesis! = NOT operation. = AND operation ^ = EXCLUSIVE OR operation E (followed by a digit) = Equation number F (Followed by a digit) = Function Key number I (Followed by a digit) = Binary Input number L (Followed by a digit) = LED number O (Followed by a digit) = output relay number V (Followed by a digit) = Virtual Input/Output number. Examples Make a function key LED toggle when function key is pressed (requires E1 to drive L11 in output matrix) $E1 = F3 \wedge L11$</p>	(20 Character String)		
<p>E1 Pickup Delay</p> <p>Time before equation output operates, after equation satisfied</p>	0, 0.01 ... 14300, 14400	0s	
<p>E1 Dropoff Delay</p> <p>Time before equation output resets, after equation no longer satisfied</p>	0, 0.01 ... 14300, 14400	0s	
<p>E1 Counter Target</p> <p>Select number of times equation must be satisfied before equation output operates</p>	1, 2 ... 998, 999	1	
<p>E1 Counter Reset Mode</p> <p>Select type of counter reset mode</p>	Off, Multi-shot, Single-shot	Off	
<p>E1 Counter Reset Time</p> <p>Select counter reset time</p>	0, 0.01 ... 14300, 14400	0s	
<p>E2 Equation</p> <p>Enable or Disable logic equation E2</p>	Disabled, Enabled	Disabled	
<p>E2</p> <p>Specify logic equations of the form $E_n = \langle \text{Operand} \rangle \langle \text{Operator} \rangle \langle \text{Operand} \rangle$ using the following: 0123456789=Digit() = Parenthesis! = NOT operation. = AND operation ^ = EXCLUSIVE OR operation E (followed by a digit) = Equation number F (Followed by a digit) = Function Key number I (Followed by a digit) = Binary Input number L (Followed by a digit) = LED number O (Followed by a digit) = output relay number V (Followed by a digit) = Virtual Input/Output number. Examples Make a function key LED toggle when function key is pressed (requires E1 to drive L11 in output matrix) $E1 = F3 \wedge L11$</p>	(20 Character String)		
<p>E2 Pickup Delay</p> <p>Time before equation output operates, after equation satisfied</p>	0, 0.01 ... 14300, 14400	0s	
<p>E2 Dropoff Delay</p> <p>Time before equation output resets, after equation no longer satisfied</p>	0, 0.01 ... 14300, 14400	0s	
<p>E2 Counter Target</p> <p>Select number of times equation must be satisfied before equation output operates</p>	1, 2 ... 998, 999	1	
<p>E2 Counter Reset Mode</p> <p>Select type of counter reset mode</p>	Off, Multi-shot, Single-shot	Off	

Description	Range	Default	Setting
E2 Counter Reset Time <i>Select counter reset time</i>	0, 0.01 ... 14300, 14400	0s	
E3 Equation <i>Enable or Disable logic equation E3</i>	Disabled, Enabled	Disabled	
E3 <i>Specify logic equations of the form En = <Operand><Operator><Operand>using the following:0123456789=Digit() = Parenthesis! = NOT operation. = AND operation^ = EXCLUSIVE OR operationE(followed by a digit) = Equation numberF (Followed by a digit) = Function Key numberI(Followed by a digit) = Binary Input numberL(Followed by a digit) = LED numberO(Followed by a digit) = output relay numberV(Followed by a digit) =Virtual Input/Output number.ExamplesMake a function key LED toggle when function key is pressed (requires E1 to drive L11 in output matrix)E1 = F3^L11</i>	(20 Character String)		
E3 Pickup Delay <i>Time before equation output operates, after equation satisfied</i>	0, 0.01 ... 14300, 14400	0s	
E3 Dropoff Delay <i>Time before equation output resets, after equation no longer satisfied</i>	0, 0.01 ... 14300, 14400	0s	
E3 Counter Target <i>Select number of times equation must be satisfied before equation output operates</i>	1, 2 ... 998, 999	1	
E3 Counter Reset Mode <i>Select type of counter reset mode</i>	Off, Multi-shot, Single-shot	Off	
E3 Counter Reset Time <i>Select counter reset time</i>	0, 0.01 ... 14300, 14400	0s	
E4 Equation <i>Enable or Disable logic equation E4</i>	Disabled, Enabled	Disabled	
E4 <i>Specify logic equations of the form En = <Operand><Operator><Operand>using the following:0123456789=Digit() = Parenthesis! = NOT operation. = AND operation^ = EXCLUSIVE OR operationE(followed by a digit) = Equation numberF (Followed by a digit) = Function Key numberI(Followed by a digit) = Binary Input numberL(Followed by a digit) = LED numberO(Followed by a digit) = output relay numberV(Followed by a digit) =Virtual Input/Output number.ExamplesMake a function key LED toggle when function key is pressed (requires E1 to drive L11 in output matrix)E1 = F3^L11</i>	(20 Character String)		
E4 Pickup Delay <i>Time before equation output operates, after equation satisfied</i>	0, 0.01 ... 14300, 14400	0s	
E4 Dropoff Delay <i>Time before equation output resets, after equation no longer satisfied</i>	0, 0.01 ... 14300, 14400	0s	

Description	Range	Default	Setting
E4 Counter Target <i>Select number of times equation must be satisfied before equation output operates</i>	1, 2 ... 998, 999	1	
E4 Counter Reset Mode <i>Select type of counter reset mode</i>	Off, Multi-shot, Single-shot	Off	
E4 Counter Reset Time <i>Select counter reset time</i>	0, 0.01 ... 14300, 14400	0s	
E5 Equation <i>Enable or Disable logic equation E5</i>	Disabled, Enabled	Disabled	
E5 <i>Specify logic equations of the form En = <Operand><Operator><Operand>using the following:0123456789=Digit() = Parenthesis! = NOT operation. = AND operation^ = EXCLUSIVE OR operationE(followed by a digit) = Equation numberF (Followed by a digit) = Function Key numberI(Followed by a digit) = Binary Input numberL(Followed by a digit) = LED numberO(Followed by a digit) = output relay numberV(Followed by a digit) =Virtual Input/Output number.ExamplesMake a function key LED toggle when function key is pressed (requires E1 to drive L11 in output matrix)E1 = F3^L11</i>	(20 Character String)		
E5 Pickup Delay <i>Time before equation output operates, after equation satisfied</i>	0, 0.01 ... 14300, 14400	0s	
E5 Dropoff Delay <i>Time before equation output resets, after equation no longer satisfied</i>	0, 0.01 ... 14300, 14400	0s	
E5 Counter Target <i>Select number of times equation must be satisfied before equation output operates</i>	1, 2 ... 998, 999	1	
E5 Counter Reset Mode <i>Select type of counter reset mode</i>	Off, Multi-shot, Single-shot	Off	
E5 Counter Reset Time <i>Select counter reset time</i>	0, 0.01 ... 14300, 14400	0s	
E6 Equation <i>Enable or Disable logic equation E6</i>	Disabled, Enabled	Disabled	
E6 <i>Specify logic equations of the form En = <Operand><Operator><Operand>using the following:0123456789=Digit() = Parenthesis! = NOT operation. = AND operation^ = EXCLUSIVE OR operationE(followed by a digit) = Equation numberF (Followed by a digit) = Function Key numberI(Followed by a digit) = Binary Input numberL(Followed by a digit) = LED numberO(Followed by a digit) = output relay numberV(Followed by a digit) =Virtual Input/Output number.ExamplesMake a function key LED toggle when function key is pressed (requires E1 to drive L11 in output matrix)E1 = F3^L11</i>	(20 Character String)		

Description	Range	Default	Setting
E6 Pickup Delay <i>Time before equation output operates, after equation satisfied</i>	0, 0.01 ... 14300, 14400	0s	
E6 Dropoff Delay <i>Time before equation output resets, after equation no longer satisfied</i>	0, 0.01 ... 14300, 14400	0s	
E6 Counter Target <i>Select number of times equation must be satisfied before equation output operates</i>	1, 2 ... 998, 999	1	
E6 Counter Reset Mode <i>Select type of counter reset mode</i>	Off, Multi-shot, Single-shot	Off	
E6 Counter Reset Time <i>Select counter reset time</i>	0, 0.01 ... 14300, 14400	0s	
E7 Equation <i>Enable or Disable logic equation E7</i>	Disabled, Enabled	Disabled	
E7 <i>Specify logic equations of the form En = <Operand><Operator><Operand> using the following: 0123456789=Digit() = Parenthesis! = NOT operation. = AND operation ^ = EXCLUSIVE OR operation E (followed by a digit) = Equation number F (Followed by a digit) = Function Key number I (Followed by a digit) = Binary Input number L (Followed by a digit) = LED number O (Followed by a digit) = output relay number V (Followed by a digit) = Virtual Input/Output number. Examples Make a function key LED toggle when function key is pressed (requires E1 to drive L11 in output matrix) E1 = F3^L11</i>	(20 Character String)		
E7 Pickup Delay <i>Time before equation output operates, after equation satisfied</i>	0, 0.01 ... 14300, 14400	0s	
E7 Dropoff Delay <i>Time before equation output resets, after equation no longer satisfied</i>	0, 0.01 ... 14300, 14400	0s	
E7 Counter Target <i>Select number of times equation must be satisfied before equation output operates</i>	1, 2 ... 998, 999	1	
E7 Counter Reset Mode <i>Select type of counter reset mode</i>	Off, Multi-shot, Single-shot	Off	
E7 Counter Reset Time <i>Select counter reset time</i>	0, 0.01 ... 14300, 14400	0s	
E8 Equation <i>Enable or Disable logic equation E8</i>	Disabled, Enabled	Disabled	

Description	Range	Default	Setting
<p>E8</p> <p>Specify logic equations of the form $E_n = \langle \text{Operand} \rangle \langle \text{Operator} \rangle \langle \text{Operand} \rangle$ using the following: 0123456789=Digit() = Parenthesis! = NOT operation. = AND operation ^ = EXCLUSIVE OR operation E (followed by a digit) = Equation number F (Followed by a digit) = Function Key number I (Followed by a digit) = Binary Input number L (Followed by a digit) = LED number O (Followed by a digit) = output relay number V (Followed by a digit) = Virtual Input/Output number. Examples Make a function key LED toggle when function key is pressed (requires E1 to drive L11 in output matrix) $E1 = F3 \wedge L11$</p>	(20 Character String)		
<p>E8 Pickup Delay</p> <p>Time before equation output operates, after equation satisfied</p>	0, 0.01 ... 14300, 14400	0s	
<p>E8 Dropoff Delay</p> <p>Time before equation output resets, after equation no longer satisfied</p>	0, 0.01 ... 14300, 14400	0s	
<p>E8 Counter Target</p> <p>Select number of times equation must be satisfied before equation output operates</p>	1, 2 ... 998, 999	1	
<p>E8 Counter Reset Mode</p> <p>Select type of counter reset mode</p>	Off, Multi-shot, Single-shot	Off	
<p>E8 Counter Reset Time</p> <p>Select counter reset time</p>	0, 0.01 ... 14300, 14400	0s	
<p>E9 Equation</p> <p>Enable or Disable logic equation E9</p>	Disabled, Enabled	Disabled	
<p>E9</p> <p>Specify logic equations of the form $E_n = \langle \text{Operand} \rangle \langle \text{Operator} \rangle \langle \text{Operand} \rangle$ using the following: 0123456789=Digit() = Parenthesis! = NOT operation. = AND operation ^ = EXCLUSIVE OR operation E (followed by a digit) = Equation number F (Followed by a digit) = Function Key number I (Followed by a digit) = Binary Input number L (Followed by a digit) = LED number O (Followed by a digit) = output relay number V (Followed by a digit) = Virtual Input/Output number. Examples Make a function key LED toggle when function key is pressed (requires E1 to drive L11 in output matrix) $E1 = F3 \wedge L11$</p>	(20 Character String)		
<p>E9 Pickup Delay</p> <p>Time before equation output operates, after equation satisfied</p>	0, 0.01 ... 14300, 14400	0s	
<p>E9 Dropoff Delay</p> <p>Time before equation output resets, after equation no longer satisfied</p>	0, 0.01 ... 14300, 14400	0s	
<p>E9 Counter Target</p> <p>Select number of times equation must be satisfied before equation output operates</p>	1, 2 ... 998, 999	1	
<p>E9 Counter Reset Mode</p> <p>Select type of counter reset mode</p>	Off, Multi-shot, Single-shot	Off	

Description	Range	Default	Setting
E9 Counter Reset Time <i>Select counter reset time</i>	0, 0.01 ... 14300, 14400	0s	
E10 Equation <i>Enable or Disable logic equation E10</i>	Disabled, Enabled	Disabled	
E10 <i>Specify logic equations of the form En = <Operand><Operator><Operand>using the following:0123456789=Digit() = Parenthesis! = NOT operation. = AND operation^ = EXCLUSIVE OR operationE(followed by a digit) = Equation numberF (Followed by a digit) = Function Key numberI(Followed by a digit) = Binary Input numberL(Followed by a digit) = LED numberO(Followed by a digit) = output relay numberV(Followed by a digit) =Virtual Input/Output number.ExamplesMake a function key LED toggle when function key is pressed (requires E1 to drive L11 in output matrix)E1 = F3^L11</i>	(20 Character String)		
E10 Pickup Delay <i>Time before equation output operates, after equation satisfied</i>	0, 0.01 ... 14300, 14400	0s	
E10 Dropoff Delay <i>Time before equation output resets, after equation no longer satisfied</i>	0, 0.01 ... 14300, 14400	0s	
E10 Counter Target <i>Select number of times equation must be satisfied before equation output operates</i>	1, 2 ... 998, 999	1	
E10 Counter Reset Mode <i>Select type of counter reset mode</i>	Off, Multi-shot, Single-shot	Off	
E10 Counter Reset Time <i>Select counter reset time</i>	0, 0.01 ... 14300, 14400	0s	
E11 Equation <i>Enable or Disable logic equation E11</i>	Disabled, Enabled	Disabled	
E11 <i>Specify logic equations of the form En = <Operand><Operator><Operand>using the following:0123456789=Digit() = Parenthesis! = NOT operation. = AND operation^ = EXCLUSIVE OR operationE(followed by a digit) = Equation numberF (Followed by a digit) = Function Key numberI(Followed by a digit) = Binary Input numberL(Followed by a digit) = LED numberO(Followed by a digit) = output relay numberV(Followed by a digit) =Virtual Input/Output number.ExamplesMake a function key LED toggle when function key is pressed (requires E1 to drive L11 in output matrix)E1 = F3^L11</i>	(20 Character String)		
E11 Pickup Delay <i>Time before equation output operates, after equation satisfied</i>	0, 0.01 ... 14300, 14400	0s	
E11 Dropoff Delay <i>Time before equation output resets, after equation no longer satisfied</i>	0, 0.01 ... 14300, 14400	0s	

Description	Range	Default	Setting
E11 Counter Target <i>Select number of times equation must be satisfied before equation output operates</i>	1, 2 ... 998, 999	1	
E11 Counter Reset Mode <i>Select type of counter reset mode</i>	Off, Multi-shot, Single-shot	Off	
E11 Counter Reset Time <i>Select counter reset time</i>	0, 0.01 ... 14300, 14400	0s	
E12 Equation <i>Enable or Disable logic equation E12</i>	Disabled, Enabled	Disabled	
E12 <i>Specify logic equations of the form En = <Operand><Operator><Operand>using the following:0123456789=Digit() = Parenthesis! = NOT operation. = AND operation^ = EXCLUSIVE OR operationE(followed by a digit) = Equation numberF (Followed by a digit) = Function Key numberI(Followed by a digit) = Binary Input numberL(Followed by a digit) = LED numberO(Followed by a digit) = output relay numberV(Followed by a digit) =Virtual Input/Output number.ExamplesMake a function key LED toggle when function key is pressed (requires E1 to drive L11 in output matrix)E1 = F3^L11</i>	(20 Character String)		
E12 Pickup Delay <i>Time before equation output operates, after equation satisfied</i>	0, 0.01 ... 14300, 14400	0s	
E12 Dropoff Delay <i>Time before equation output resets, after equation no longer satisfied</i>	0, 0.01 ... 14300, 14400	0s	
E12 Counter Target <i>Select number of times equation must be satisfied before equation output operates</i>	1, 2 ... 998, 999	1	
E12 Counter Reset Mode <i>Select type of counter reset mode</i>	Off, Multi-shot, Single-shot	Off	
E12 Counter Reset Time <i>Select counter reset time</i>	0, 0.01 ... 14300, 14400	0s	
E13 Equation <i>Enable or Disable logic equation E13</i>	Disabled, Enabled	Disabled	
E13 <i>Specify logic equations of the form En = <Operand><Operator><Operand>using the following:0123456789=Digit() = Parenthesis! = NOT operation. = AND operation^ = EXCLUSIVE OR operationE(followed by a digit) = Equation numberF (Followed by a digit) = Function Key numberI(Followed by a digit) = Binary Input numberL(Followed by a digit) = LED numberO(Followed by a digit) = output relay numberV(Followed by a digit) =Virtual Input/Output number.ExamplesMake a function key LED toggle when function key is pressed (requires E1 to drive L11 in output matrix)E1 = F3^L11</i>	(20 Character String)		

Description	Range	Default	Setting
E13 Pickup Delay <i>Time before equation output operates, after equation satisfied</i>	0, 0.01 ... 14300, 14400	0s	
E13 Dropoff Delay <i>Time before equation output resets, after equation no longer satisfied</i>	0, 0.01 ... 14300, 14400	0s	
E13 Counter Target <i>Select number of times equation must be satisfied before equation output operates</i>	1, 2 ... 998, 999	1	
E13 Counter Reset Mode <i>Select type of counter reset mode</i>	Off, Multi-shot, Single-shot	Off	
E13 Counter Reset Time <i>Select counter reset time</i>	0, 0.01 ... 14300, 14400	0s	
E14 Equation <i>Enable or Disable logic equation E14</i>	Disabled, Enabled	Disabled	
E14 <i>Specify logic equations of the form En = <Operand><Operator><Operand> using the following: 0123456789=Digit() = Parenthesis! = NOT operation. = AND operation ^ = EXCLUSIVE OR operation E (followed by a digit) = Equation number F (Followed by a digit) = Function Key number I (Followed by a digit) = Binary Input number L (Followed by a digit) = LED number O (Followed by a digit) = output relay number V (Followed by a digit) = Virtual Input/Output number. Examples Make a function key LED toggle when function key is pressed (requires E1 to drive L11 in output matrix) E1 = F3^L11</i>	(20 Character String)		
E14 Pickup Delay <i>Time before equation output operates, after equation satisfied</i>	0, 0.01 ... 14300, 14400	0s	
E14 Dropoff Delay <i>Time before equation output resets, after equation no longer satisfied</i>	0, 0.01 ... 14300, 14400	0s	
E14 Counter Target <i>Select number of times equation must be satisfied before equation output operates</i>	1, 2 ... 998, 999	1	
E14 Counter Reset Mode <i>Select type of counter reset mode</i>	Off, Multi-shot, Single-shot	Off	
E14 Counter Reset Time <i>Select counter reset time</i>	0, 0.01 ... 14300, 14400	0s	
E15 Equation <i>Enable or Disable logic equation E15</i>	Disabled, Enabled	Disabled	

Description	Range	Default	Setting
E15 Specify logic equations of the form $E_n = \langle \text{Operand} \rangle \langle \text{Operator} \rangle \langle \text{Operand} \rangle$ using the following: 0123456789=Digit() = Parenthesis! = NOT operation. = AND operation ^ = EXCLUSIVE OR operation E (followed by a digit) = Equation number F (Followed by a digit) = Function Key number I (Followed by a digit) = Binary Input number L (Followed by a digit) = LED number O (Followed by a digit) = output relay number V (Followed by a digit) = Virtual Input/Output number. Examples Make a function key LED toggle when function key is pressed (requires E1 to drive L11 in output matrix) $E1 = F3 \wedge L11$	(20 Character String)		
E15 Pickup Delay Time before equation output operates, after equation satisfied	0, 0.01 ... 14300, 14400	0s	
E15 Dropoff Delay Time before equation output resets, after equation no longer satisfied	0, 0.01 ... 14300, 14400	0s	
E15 Counter Target Select number of times equation must be satisfied before equation output operates	1, 2 ... 998, 999	1	
E15 Counter Reset Mode Select type of counter reset mode	Off, Multi-shot, Single-shot	Off	
E15 Counter Reset Time Select counter reset time	0, 0.01 ... 14300, 14400	0s	
E16 Equation Enable or Disable logic equation E16	Disabled, Enabled	Disabled	
E16 Specify logic equations of the form $E_n = \langle \text{Operand} \rangle \langle \text{Operator} \rangle \langle \text{Operand} \rangle$ using the following: 0123456789=Digit() = Parenthesis! = NOT operation. = AND operation ^ = EXCLUSIVE OR operation E (followed by a digit) = Equation number F (Followed by a digit) = Function Key number I (Followed by a digit) = Binary Input number L (Followed by a digit) = LED number O (Followed by a digit) = output relay number V (Followed by a digit) = Virtual Input/Output number. Examples Make a function key LED toggle when function key is pressed (requires E1 to drive L11 in output matrix) $E1 = F3 \wedge L11$	(20 Character String)		
E16 Pickup Delay Time before equation output operates, after equation satisfied	0, 0.01 ... 14300, 14400	0s	
E16 Dropoff Delay Time before equation output resets, after equation no longer satisfied	0, 0.01 ... 14300, 14400	0s	
E16 Counter Target Select number of times equation must be satisfied before equation output operates	1, 2 ... 998, 999	1	
E16 Counter Reset Mode Select type of counter reset mode	Off, Multi-shot, Single-shot	Off	

Description	Range	Default	Setting
E16 Counter Reset Time <i>Select counter reset time</i>	0, 0.01 ... 14300, 14400	0s	

5.8. Input Config

5.8.1. Input Matrix

Description	Range	Default	Setting
Inhibit 51-1 <i>Selects which inputs inhibit the 51-1 element</i>	Combination of (BI1, BI2, BI3, BI4, BI5, BI6, BI7, BI8, BI9, BI10, BI11, BI12, BI13, BI14, BI15, BI16, BI17, BI18, BI19, BI20, BI21, BI22, BI23, BI24, BI25, BI26, BI27, BI28, BI29, BI30, BI31, BI32, BI33, BI34, BI35, BI36, BI37, BI38, BI39, BI40, BI41, BI42, BI43, V1, V2, V3, V4, V5, V6, V7, V8, V9, V10, V11, V12, V13, V14)	----- ----- -----	
Inhibit 51-2 <i>Selects which inputs inhibit the 51-2 element</i>	Combination of (BI1, BI2, BI3, BI4, BI5, BI6, BI7, BI8, BI9, BI10, BI11, BI12, BI13, BI14, BI15, BI16, BI17, BI18, BI19, BI20, BI21, BI22, BI23, BI24, BI25, BI26, BI27, BI28, BI29, BI30, BI31, BI32, BI33, BI34, BI35, BI36, BI37, BI38, BI39, BI40, BI41, BI42, BI43, V1, V2, V3, V4, V5, V6, V7, V8, V9, V10, V11, V12, V13, V14)	----- ----- -----	
Inhibit 51-3 <i>Selects which inputs inhibit the 51-3 element</i>	Combination of (BI1, BI2, BI3, BI4, BI5, BI6, BI7, BI8, BI9, BI10, BI11, BI12, BI13, BI14, BI15, BI16, BI17, BI18, BI19, BI20, BI21, BI22, BI23, BI24, BI25, BI26, BI27, BI28, BI29, BI30, BI31, BI32, BI33, BI34, BI35, BI36, BI37, BI38, BI39, BI40, BI41, BI42, BI43, V1, V2, V3, V4, V5, V6, V7, V8, V9, V10, V11, V12, V13, V14)	----- ----- -----	
Inhibit 51-4 <i>Selects which inputs inhibit the 51-4 element</i>	Combination of (BI1, BI2, BI3, BI4, BI5, BI6, BI7, BI8, BI9, BI10, BI11, BI12, BI13, BI14, BI15, BI16, BI17, BI18, BI19, BI20, BI21, BI22, BI23, BI24, BI25, BI26, BI27, BI28, BI29, BI30, BI31, BI32, BI33, BI34, BI35, BI36, BI37, BI38, BI39, BI40, BI41, BI42, BI43, V1, V2, V3, V4, V5, V6, V7, V8, V9, V10, V11, V12, V13, V14)	----- ----- -----	

Description	Range	Default	Setting
Inhibit 50-1 <i>Selects which inputs inhibit the 50-1 element</i>	Combination of (BI1, BI2, BI3, BI4, BI5, BI6, BI7, BI8, BI9, BI10, BI11, BI12, BI13, BI14, BI15, BI16, BI17, BI18, BI19, BI20, BI21, BI22, BI23, BI24, BI25, BI26, BI27, BI28, BI29, BI30, BI31, BI32, BI33, BI34, BI35, BI36, BI37, BI38, BI39, BI40, BI41, BI42, BI43, V1, V2, V3, V4, V5, V6, V7, V8, V9, V10, V11, V12, V13, V14)	----- ----- -----	
Inhibit 50-2 <i>Selects which inputs inhibit the 50-2 element</i>	Combination of (BI1, BI2, BI3, BI4, BI5, BI6, BI7, BI8, BI9, BI10, BI11, BI12, BI13, BI14, BI15, BI16, BI17, BI18, BI19, BI20, BI21, BI22, BI23, BI24, BI25, BI26, BI27, BI28, BI29, BI30, BI31, BI32, BI33, BI34, BI35, BI36, BI37, BI38, BI39, BI40, BI41, BI42, BI43, V1, V2, V3, V4, V5, V6, V7, V8, V9, V10, V11, V12, V13, V14)	----- ----- -----	
Inhibit 50-3 <i>Selects which inputs inhibit the 50-3 element</i>	Combination of (BI1, BI2, BI3, BI4, BI5, BI6, BI7, BI8, BI9, BI10, BI11, BI12, BI13, BI14, BI15, BI16, BI17, BI18, BI19, BI20, BI21, BI22, BI23, BI24, BI25, BI26, BI27, BI28, BI29, BI30, BI31, BI32, BI33, BI34, BI35, BI36, BI37, BI38, BI39, BI40, BI41, BI42, BI43, V1, V2, V3, V4, V5, V6, V7, V8, V9, V10, V11, V12, V13, V14)	----- ----- -----	
Inhibit 50-4 <i>Selects which inputs inhibit the 50-4 element</i>	Combination of (BI1, BI2, BI3, BI4, BI5, BI6, BI7, BI8, BI9, BI10, BI11, BI12, BI13, BI14, BI15, BI16, BI17, BI18, BI19, BI20, BI21, BI22, BI23, BI24, BI25, BI26, BI27, BI28, BI29, BI30, BI31, BI32, BI33, BI34, BI35, BI36, BI37, BI38, BI39, BI40, BI41, BI42, BI43, V1, V2, V3, V4, V5, V6, V7, V8, V9, V10, V11, V12, V13, V14)	----- ----- -----	
Inhibit 51G-1 <i>Selects which inputs inhibit the 51G-1 element</i>	Combination of (BI1, BI2, BI3, BI4, BI5, BI6, BI7, BI8, BI9, BI10, BI11, BI12, BI13, BI14, BI15, BI16, BI17, BI18, BI19, BI20, BI21, BI22, BI23, BI24, BI25, BI26, BI27, BI28, BI29, BI30, BI31, BI32, BI33, BI34, BI35, BI36, BI37, BI38, BI39, BI40, BI41, BI42, BI43, V1, V2, V3, V4, V5, V6, V7, V8, V9, V10, V11, V12, V13, V14)	----- ----- -----	

Description	Range	Default	Setting
Inhibit 51G-2 <i>Selects which inputs inhibit the 51G-2 element</i>	Combination of (BI1, BI2, BI3, BI4, BI5, BI6, BI7, BI8, BI9, BI10, BI11, BI12, BI13, BI14, BI15, BI16, BI17, BI18, BI19, BI20, BI21, BI22, BI23, BI24, BI25, BI26, BI27, BI28, BI29, BI30, BI31, BI32, BI33, BI34, BI35, BI36, BI37, BI38, BI39, BI40, BI41, BI42, BI43, V1, V2, V3, V4, V5, V6, V7, V8, V9, V10, V11, V12, V13, V14)	----- ----- -----	
Inhibit 51G-3 <i>Selects which inputs inhibit the 51G-3 element</i>	Combination of (BI1, BI2, BI3, BI4, BI5, BI6, BI7, BI8, BI9, BI10, BI11, BI12, BI13, BI14, BI15, BI16, BI17, BI18, BI19, BI20, BI21, BI22, BI23, BI24, BI25, BI26, BI27, BI28, BI29, BI30, BI31, BI32, BI33, BI34, BI35, BI36, BI37, BI38, BI39, BI40, BI41, BI42, BI43, V1, V2, V3, V4, V5, V6, V7, V8, V9, V10, V11, V12, V13, V14)	----- ----- -----	
Inhibit 51G-4 <i>Selects which inputs inhibit the 51G-4 element</i>	Combination of (BI1, BI2, BI3, BI4, BI5, BI6, BI7, BI8, BI9, BI10, BI11, BI12, BI13, BI14, BI15, BI16, BI17, BI18, BI19, BI20, BI21, BI22, BI23, BI24, BI25, BI26, BI27, BI28, BI29, BI30, BI31, BI32, BI33, BI34, BI35, BI36, BI37, BI38, BI39, BI40, BI41, BI42, BI43, V1, V2, V3, V4, V5, V6, V7, V8, V9, V10, V11, V12, V13, V14)	----- ----- -----	
Inhibit 50G-1 <i>Selects which inputs inhibit the 50G-1 element</i>	Combination of (BI1, BI2, BI3, BI4, BI5, BI6, BI7, BI8, BI9, BI10, BI11, BI12, BI13, BI14, BI15, BI16, BI17, BI18, BI19, BI20, BI21, BI22, BI23, BI24, BI25, BI26, BI27, BI28, BI29, BI30, BI31, BI32, BI33, BI34, BI35, BI36, BI37, BI38, BI39, BI40, BI41, BI42, BI43, V1, V2, V3, V4, V5, V6, V7, V8, V9, V10, V11, V12, V13, V14)	----- ----- -----	
Inhibit 50G-2 <i>Selects which inputs inhibit the 50G-2 element</i>	Combination of (BI1, BI2, BI3, BI4, BI5, BI6, BI7, BI8, BI9, BI10, BI11, BI12, BI13, BI14, BI15, BI16, BI17, BI18, BI19, BI20, BI21, BI22, BI23, BI24, BI25, BI26, BI27, BI28, BI29, BI30, BI31, BI32, BI33, BI34, BI35, BI36, BI37, BI38, BI39, BI40, BI41, BI42, BI43, V1, V2, V3, V4, V5, V6, V7, V8, V9, V10, V11, V12, V13, V14)	----- ----- -----	

Description	Range	Default	Setting
Inhibit 50G-3 <i>Selects which inputs inhibit the 50G-3 element</i>	Combination of (BI1, BI2, BI3, BI4, BI5, BI6, BI7, BI8, BI9, BI10, BI11, BI12, BI13, BI14, BI15, BI16, BI17, BI18, BI19, BI20, BI21, BI22, BI23, BI24, BI25, BI26, BI27, BI28, BI29, BI30, BI31, BI32, BI33, BI34, BI35, BI36, BI37, BI38, BI39, BI40, BI41, BI42, BI43, V1, V2, V3, V4, V5, V6, V7, V8, V9, V10, V11, V12, V13, V14)	----- ----- -----	
Inhibit 50G-4 <i>Selects which inputs inhibit the 50G-4 element</i>	Combination of (BI1, BI2, BI3, BI4, BI5, BI6, BI7, BI8, BI9, BI10, BI11, BI12, BI13, BI14, BI15, BI16, BI17, BI18, BI19, BI20, BI21, BI22, BI23, BI24, BI25, BI26, BI27, BI28, BI29, BI30, BI31, BI32, BI33, BI34, BI35, BI36, BI37, BI38, BI39, BI40, BI41, BI42, BI43, V1, V2, V3, V4, V5, V6, V7, V8, V9, V10, V11, V12, V13, V14)	----- ----- -----	
Inhibit 51SEF-1 <i>Selects which inputs inhibit the 51SEF-1 element</i>	Combination of (BI1, BI2, BI3, BI4, BI5, BI6, BI7, BI8, BI9, BI10, BI11, BI12, BI13, BI14, BI15, BI16, BI17, BI18, BI19, BI20, BI21, BI22, BI23, BI24, BI25, BI26, BI27, BI28, BI29, BI30, BI31, BI32, BI33, BI34, BI35, BI36, BI37, BI38, BI39, BI40, BI41, BI42, BI43, V1, V2, V3, V4, V5, V6, V7, V8, V9, V10, V11, V12, V13, V14)	----- ----- -----	
Inhibit 51SEF-2 <i>Selects which inputs inhibit the 51SEF-2 element</i>	Combination of (BI1, BI2, BI3, BI4, BI5, BI6, BI7, BI8, BI9, BI10, BI11, BI12, BI13, BI14, BI15, BI16, BI17, BI18, BI19, BI20, BI21, BI22, BI23, BI24, BI25, BI26, BI27, BI28, BI29, BI30, BI31, BI32, BI33, BI34, BI35, BI36, BI37, BI38, BI39, BI40, BI41, BI42, BI43, V1, V2, V3, V4, V5, V6, V7, V8, V9, V10, V11, V12, V13, V14)	----- ----- -----	
Inhibit 51SEF-3 <i>Selects which inputs inhibit the 51SEF-3 element</i>	Combination of (BI1, BI2, BI3, BI4, BI5, BI6, BI7, BI8, BI9, BI10, BI11, BI12, BI13, BI14, BI15, BI16, BI17, BI18, BI19, BI20, BI21, BI22, BI23, BI24, BI25, BI26, BI27, BI28, BI29, BI30, BI31, BI32, BI33, BI34, BI35, BI36, BI37, BI38, BI39, BI40, BI41, BI42, BI43, V1, V2, V3, V4, V5, V6, V7, V8, V9, V10, V11, V12, V13, V14)	----- ----- -----	

Description	Range	Default	Setting
Inhibit 51SEF-4 <i>Selects which inputs inhibit the 51SEF-4 element</i>	Combination of (BI1, BI2, BI3, BI4, BI5, BI6, BI7, BI8, BI9, BI10, BI11, BI12, BI13, BI14, BI15, BI16, BI17, BI18, BI19, BI20, BI21, BI22, BI23, BI24, BI25, BI26, BI27, BI28, BI29, BI30, BI31, BI32, BI33, BI34, BI35, BI36, BI37, BI38, BI39, BI40, BI41, BI42, BI43, V1, V2, V3, V4, V5, V6, V7, V8, V9, V10, V11, V12, V13, V14)	----- ----- -----	
Inhibit 50SEF-1 <i>Selects which inputs inhibit the 50SEF-1 element</i>	Combination of (BI1, BI2, BI3, BI4, BI5, BI6, BI7, BI8, BI9, BI10, BI11, BI12, BI13, BI14, BI15, BI16, BI17, BI18, BI19, BI20, BI21, BI22, BI23, BI24, BI25, BI26, BI27, BI28, BI29, BI30, BI31, BI32, BI33, BI34, BI35, BI36, BI37, BI38, BI39, BI40, BI41, BI42, BI43, V1, V2, V3, V4, V5, V6, V7, V8, V9, V10, V11, V12, V13, V14)	----- ----- -----	
Inhibit 50SEF-2 <i>Selects which inputs inhibit the 50SEF-2 element</i>	Combination of (BI1, BI2, BI3, BI4, BI5, BI6, BI7, BI8, BI9, BI10, BI11, BI12, BI13, BI14, BI15, BI16, BI17, BI18, BI19, BI20, BI21, BI22, BI23, BI24, BI25, BI26, BI27, BI28, BI29, BI30, BI31, BI32, BI33, BI34, BI35, BI36, BI37, BI38, BI39, BI40, BI41, BI42, BI43, V1, V2, V3, V4, V5, V6, V7, V8, V9, V10, V11, V12, V13, V14)	----- ----- -----	
Inhibit 50SEF-3 <i>Selects which inputs inhibit the 50SEF-3 element</i>	Combination of (BI1, BI2, BI3, BI4, BI5, BI6, BI7, BI8, BI9, BI10, BI11, BI12, BI13, BI14, BI15, BI16, BI17, BI18, BI19, BI20, BI21, BI22, BI23, BI24, BI25, BI26, BI27, BI28, BI29, BI30, BI31, BI32, BI33, BI34, BI35, BI36, BI37, BI38, BI39, BI40, BI41, BI42, BI43, V1, V2, V3, V4, V5, V6, V7, V8, V9, V10, V11, V12, V13, V14)	----- ----- -----	
Inhibit 50SEF-4 <i>Selects which inputs inhibit the 50SEF-4 element</i>	Combination of (BI1, BI2, BI3, BI4, BI5, BI6, BI7, BI8, BI9, BI10, BI11, BI12, BI13, BI14, BI15, BI16, BI17, BI18, BI19, BI20, BI21, BI22, BI23, BI24, BI25, BI26, BI27, BI28, BI29, BI30, BI31, BI32, BI33, BI34, BI35, BI36, BI37, BI38, BI39, BI40, BI41, BI42, BI43, V1, V2, V3, V4, V5, V6, V7, V8, V9, V10, V11, V12, V13, V14)	----- ----- -----	

Description	Range	Default	Setting
Inhibit 64H <i>Selects which inputs inhibit the 64H element</i>	Combination of (BI1, BI2, BI3, BI4, BI5, BI6, BI7, BI8, BI9, BI10, BI11, BI12, BI13, BI14, BI15, BI16, BI17, BI18, BI19, BI20, BI21, BI22, BI23, BI24, BI25, BI26, BI27, BI28, BI29, BI30, BI31, BI32, BI33, BI34, BI35, BI36, BI37, BI38, BI39, BI40, BI41, BI42, BI43, V1, V2, V3, V4, V5, V6, V7, V8, V9, V10, V11, V12, V13, V14)	----- ----- -----	
Inhibit 46IT <i>Selects which inputs inhibit the 46IT element</i>	Combination of (BI1, BI2, BI3, BI4, BI5, BI6, BI7, BI8, BI9, BI10, BI11, BI12, BI13, BI14, BI15, BI16, BI17, BI18, BI19, BI20, BI21, BI22, BI23, BI24, BI25, BI26, BI27, BI28, BI29, BI30, BI31, BI32, BI33, BI34, BI35, BI36, BI37, BI38, BI39, BI40, BI41, BI42, BI43, V1, V2, V3, V4, V5, V6, V7, V8, V9, V10, V11, V12, V13, V14)	----- ----- -----	
Inhibit 46DT <i>Selects which inputs inhibit the 46DT element</i>	Combination of (BI1, BI2, BI3, BI4, BI5, BI6, BI7, BI8, BI9, BI10, BI11, BI12, BI13, BI14, BI15, BI16, BI17, BI18, BI19, BI20, BI21, BI22, BI23, BI24, BI25, BI26, BI27, BI28, BI29, BI30, BI31, BI32, BI33, BI34, BI35, BI36, BI37, BI38, BI39, BI40, BI41, BI42, BI43, V1, V2, V3, V4, V5, V6, V7, V8, V9, V10, V11, V12, V13, V14)	----- ----- -----	
Inhibit 37-1 <i>Selects which inputs inhibit the 37-1 element</i>	Combination of (BI1, BI2, BI3, BI4, BI5, BI6, BI7, BI8, BI9, BI10, BI11, BI12, BI13, BI14, BI15, BI16, BI17, BI18, BI19, BI20, BI21, BI22, BI23, BI24, BI25, BI26, BI27, BI28, BI29, BI30, BI31, BI32, BI33, BI34, BI35, BI36, BI37, BI38, BI39, BI40, BI41, BI42, BI43, V1, V2, V3, V4, V5, V6, V7, V8, V9, V10, V11, V12, V13, V14)	----- ----- -----	
Inhibit 37-2 <i>Selects which inputs inhibit the 37-2 element</i>	Combination of (BI1, BI2, BI3, BI4, BI5, BI6, BI7, BI8, BI9, BI10, BI11, BI12, BI13, BI14, BI15, BI16, BI17, BI18, BI19, BI20, BI21, BI22, BI23, BI24, BI25, BI26, BI27, BI28, BI29, BI30, BI31, BI32, BI33, BI34, BI35, BI36, BI37, BI38, BI39, BI40, BI41, BI42, BI43, V1, V2, V3, V4, V5, V6, V7, V8, V9, V10, V11, V12, V13, V14)	----- ----- -----	

Description	Range	Default	Setting
Inhibit 49 <i>Selects which inputs inhibit the 49 thermal element</i>	Combination of (BI1, BI2, BI3, BI4, BI5, BI6, BI7, BI8, BI9, BI10, BI11, BI12, BI13, BI14, BI15, BI16, BI17, BI18, BI19, BI20, BI21, BI22, BI23, BI24, BI25, BI26, BI27, BI28, BI29, BI30, BI31, BI32, BI33, BI34, BI35, BI36, BI37, BI38, BI39, BI40, BI41, BI42, BI43, V1, V2, V3, V4, V5, V6, V7, V8, V9, V10, V11, V12, V13, V14)	----- ----- -----	
Reset 49 <i>Selects which inputs resets the 49 thermal model element</i>	Combination of (BI1, BI2, BI3, BI4, BI5, BI6, BI7, BI8, BI9, BI10, BI11, BI12, BI13, BI14, BI15, BI16, BI17, BI18, BI19, BI20, BI21, BI22, BI23, BI24, BI25, BI26, BI27, BI28, BI29, BI30, BI31, BI32, BI33, BI34, BI35, BI36, BI37, BI38, BI39, BI40, BI41, BI42, BI43, V1, V2, V3, V4, V5, V6, V7, V8, V9, V10, V11, V12, V13, V14)	----- ----- -----	
Inhibit 27/59-1 <i>Selects which inputs inhibit the 27/59-1 element</i>	Combination of (BI1, BI2, BI3, BI4, BI5, BI6, BI7, BI8, BI9, BI10, BI11, BI12, BI13, BI14, BI15, BI16, BI17, BI18, BI19, BI20, BI21, BI22, BI23, BI24, BI25, BI26, BI27, BI28, BI29, BI30, BI31, BI32, BI33, BI34, BI35, BI36, BI37, BI38, BI39, BI40, BI41, BI42, BI43, V1, V2, V3, V4, V5, V6, V7, V8, V9, V10, V11, V12, V13, V14)	----- ----- -----	
Inhibit 27/59-2 <i>Selects which inputs inhibit the 27/59-2 element</i>	Combination of (BI1, BI2, BI3, BI4, BI5, BI6, BI7, BI8, BI9, BI10, BI11, BI12, BI13, BI14, BI15, BI16, BI17, BI18, BI19, BI20, BI21, BI22, BI23, BI24, BI25, BI26, BI27, BI28, BI29, BI30, BI31, BI32, BI33, BI34, BI35, BI36, BI37, BI38, BI39, BI40, BI41, BI42, BI43, V1, V2, V3, V4, V5, V6, V7, V8, V9, V10, V11, V12, V13, V14)	----- ----- -----	
Inhibit 27/59-3 <i>Selects which inputs inhibit the 27/59-3 element</i>	Combination of (BI1, BI2, BI3, BI4, BI5, BI6, BI7, BI8, BI9, BI10, BI11, BI12, BI13, BI14, BI15, BI16, BI17, BI18, BI19, BI20, BI21, BI22, BI23, BI24, BI25, BI26, BI27, BI28, BI29, BI30, BI31, BI32, BI33, BI34, BI35, BI36, BI37, BI38, BI39, BI40, BI41, BI42, BI43, V1, V2, V3, V4, V5, V6, V7, V8, V9, V10, V11, V12, V13, V14)	----- ----- -----	

Description	Range	Default	Setting
Inhibit 27/59-4 <i>Selects which inputs inhibit the 27/59-4 element</i>	Combination of (BI1, BI2, BI3, BI4, BI5, BI6, BI7, BI8, BI9, BI10, BI11, BI12, BI13, BI14, BI15, BI16, BI17, BI18, BI19, BI20, BI21, BI22, BI23, BI24, BI25, BI26, BI27, BI28, BI29, BI30, BI31, BI32, BI33, BI34, BI35, BI36, BI37, BI38, BI39, BI40, BI41, BI42, BI43, V1, V2, V3, V4, V5, V6, V7, V8, V9, V10, V11, V12, V13, V14)	----- ----- -----	
Inhibit Vx 27/59 <i>Selects which inputs inhibit the Vx 27/59 element</i>	Combination of (BI1, BI2, BI3, BI4, BI5, BI6, BI7, BI8, BI9, BI10, BI11, BI12, BI13, BI14, BI15, BI16, BI17, BI18, BI19, BI20, BI21, BI22, BI23, BI24, BI25, BI26, BI27, BI28, BI29, BI30, BI31, BI32, BI33, BI34, BI35, BI36, BI37, BI38, BI39, BI40, BI41, BI42, BI43, V1, V2, V3, V4, V5, V6, V7, V8, V9, V10, V11, V12, V13, V14)	----- ----- -----	
Inhibit 47-1 <i>Selects which inputs inhibit the 47-1 element</i>	Combination of (BI1, BI2, BI3, BI4, BI5, BI6, BI7, BI8, BI9, BI10, BI11, BI12, BI13, BI14, BI15, BI16, BI17, BI18, BI19, BI20, BI21, BI22, BI23, BI24, BI25, BI26, BI27, BI28, BI29, BI30, BI31, BI32, BI33, BI34, BI35, BI36, BI37, BI38, BI39, BI40, BI41, BI42, BI43, V1, V2, V3, V4, V5, V6, V7, V8, V9, V10, V11, V12, V13, V14)	----- ----- -----	
Inhibit 47-2 <i>Selects which inputs inhibit the 47-2 element</i>	Combination of (BI1, BI2, BI3, BI4, BI5, BI6, BI7, BI8, BI9, BI10, BI11, BI12, BI13, BI14, BI15, BI16, BI17, BI18, BI19, BI20, BI21, BI22, BI23, BI24, BI25, BI26, BI27, BI28, BI29, BI30, BI31, BI32, BI33, BI34, BI35, BI36, BI37, BI38, BI39, BI40, BI41, BI42, BI43, V1, V2, V3, V4, V5, V6, V7, V8, V9, V10, V11, V12, V13, V14)	----- ----- -----	
Inhibit 59NIT <i>Selects which inputs inhibit the 59N IDMTL/DTL element</i>	Combination of (BI1, BI2, BI3, BI4, BI5, BI6, BI7, BI8, BI9, BI10, BI11, BI12, BI13, BI14, BI15, BI16, BI17, BI18, BI19, BI20, BI21, BI22, BI23, BI24, BI25, BI26, BI27, BI28, BI29, BI30, BI31, BI32, BI33, BI34, BI35, BI36, BI37, BI38, BI39, BI40, BI41, BI42, BI43, V1, V2, V3, V4, V5, V6, V7, V8, V9, V10, V11, V12, V13, V14)	----- ----- -----	

Description	Range	Default	Setting
Inhibit 59NDT <i>Selects which inputs inhibit the 59N INST/DTL element</i>	Combination of (BI1, BI2, BI3, BI4, BI5, BI6, BI7, BI8, BI9, BI10, BI11, BI12, BI13, BI14, BI15, BI16, BI17, BI18, BI19, BI20, BI21, BI22, BI23, BI24, BI25, BI26, BI27, BI28, BI29, BI30, BI31, BI32, BI33, BI34, BI35, BI36, BI37, BI38, BI39, BI40, BI41, BI42, BI43, V1, V2, V3, V4, V5, V6, V7, V8, V9, V10, V11, V12, V13, V14)	----- ----- -----	
Inhibit 81-1 <i>Selects which inputs inhibit the 81-1 element</i>	Combination of (BI1, BI2, BI3, BI4, BI5, BI6, BI7, BI8, BI9, BI10, BI11, BI12, BI13, BI14, BI15, BI16, BI17, BI18, BI19, BI20, BI21, BI22, BI23, BI24, BI25, BI26, BI27, BI28, BI29, BI30, BI31, BI32, BI33, BI34, BI35, BI36, BI37, BI38, BI39, BI40, BI41, BI42, BI43, V1, V2, V3, V4, V5, V6, V7, V8, V9, V10, V11, V12, V13, V14)	----- ----- -----	
Inhibit 81-2 <i>Selects which inputs inhibit the 81-2 element</i>	Combination of (BI1, BI2, BI3, BI4, BI5, BI6, BI7, BI8, BI9, BI10, BI11, BI12, BI13, BI14, BI15, BI16, BI17, BI18, BI19, BI20, BI21, BI22, BI23, BI24, BI25, BI26, BI27, BI28, BI29, BI30, BI31, BI32, BI33, BI34, BI35, BI36, BI37, BI38, BI39, BI40, BI41, BI42, BI43, V1, V2, V3, V4, V5, V6, V7, V8, V9, V10, V11, V12, V13, V14)	----- ----- -----	
Inhibit 81-3 <i>Selects which inputs inhibit the 81-3 element</i>	Combination of (BI1, BI2, BI3, BI4, BI5, BI6, BI7, BI8, BI9, BI10, BI11, BI12, BI13, BI14, BI15, BI16, BI17, BI18, BI19, BI20, BI21, BI22, BI23, BI24, BI25, BI26, BI27, BI28, BI29, BI30, BI31, BI32, BI33, BI34, BI35, BI36, BI37, BI38, BI39, BI40, BI41, BI42, BI43, V1, V2, V3, V4, V5, V6, V7, V8, V9, V10, V11, V12, V13, V14)	----- ----- -----	
Inhibit 81-4 <i>Selects which inputs inhibit the 81-4 element</i>	Combination of (BI1, BI2, BI3, BI4, BI5, BI6, BI7, BI8, BI9, BI10, BI11, BI12, BI13, BI14, BI15, BI16, BI17, BI18, BI19, BI20, BI21, BI22, BI23, BI24, BI25, BI26, BI27, BI28, BI29, BI30, BI31, BI32, BI33, BI34, BI35, BI36, BI37, BI38, BI39, BI40, BI41, BI42, BI43, V1, V2, V3, V4, V5, V6, V7, V8, V9, V10, V11, V12, V13, V14)	----- ----- -----	

Description	Range	Default	Setting
Inhibit 60CTS <i>Selects which inputs inhibit the CT Supervision element</i>	Combination of (BI1, BI2, BI3, BI4, BI5, BI6, BI7, BI8, BI9, BI10, BI11, BI12, BI13, BI14, BI15, BI16, BI17, BI18, BI19, BI20, BI21, BI22, BI23, BI24, BI25, BI26, BI27, BI28, BI29, BI30, BI31, BI32, BI33, BI34, BI35, BI36, BI37, BI38, BI39, BI40, BI41, BI42, BI43, V1, V2, V3, V4, V5, V6, V7, V8, V9, V10, V11, V12, V13, V14)	----- ----- -----	
Inhibit 46BC <i>Selects which inputs inhibit the 46 Broken Conductor element</i>	Combination of (BI1, BI2, BI3, BI4, BI5, BI6, BI7, BI8, BI9, BI10, BI11, BI12, BI13, BI14, BI15, BI16, BI17, BI18, BI19, BI20, BI21, BI22, BI23, BI24, BI25, BI26, BI27, BI28, BI29, BI30, BI31, BI32, BI33, BI34, BI35, BI36, BI37, BI38, BI39, BI40, BI41, BI42, BI43, V1, V2, V3, V4, V5, V6, V7, V8, V9, V10, V11, V12, V13, V14)	----- ----- -----	
74TCS-1 <i>Selects which inputs are monitoring trip circuits</i>	Combination of (BI1, BI2, BI3, BI4, BI5, BI6, BI7, BI8, BI9, BI10, BI11, BI12, BI13, BI14, BI15, BI16, BI17, BI18, BI19, BI20, BI21, BI22, BI23, BI24, BI25, BI26, BI27, BI28, BI29, BI30, BI31, BI32, BI33, BI34, BI35, BI36, BI37, BI38, BI39, BI40, BI41, BI42, BI43, V1, V2, V3, V4, V5, V6, V7, V8, V9, V10, V11, V12, V13, V14)	----- ----- -----	
74TCS-2 <i>As Above</i>	Combination of (BI1, BI2, BI3, BI4, BI5, BI6, BI7, BI8, BI9, BI10, BI11, BI12, BI13, BI14, BI15, BI16, BI17, BI18, BI19, BI20, BI21, BI22, BI23, BI24, BI25, BI26, BI27, BI28, BI29, BI30, BI31, BI32, BI33, BI34, BI35, BI36, BI37, BI38, BI39, BI40, BI41, BI42, BI43, V1, V2, V3, V4, V5, V6, V7, V8, V9, V10, V11, V12, V13, V14)	----- ----- -----	
74TCS-3 <i>As Above</i>	Combination of (BI1, BI2, BI3, BI4, BI5, BI6, BI7, BI8, BI9, BI10, BI11, BI12, BI13, BI14, BI15, BI16, BI17, BI18, BI19, BI20, BI21, BI22, BI23, BI24, BI25, BI26, BI27, BI28, BI29, BI30, BI31, BI32, BI33, BI34, BI35, BI36, BI37, BI38, BI39, BI40, BI41, BI42, BI43, V1, V2, V3, V4, V5, V6, V7, V8, V9, V10, V11, V12, V13, V14)	----- ----- -----	

Description	Range	Default	Setting
Trig Trip Contacts A <i>Selects which inputs will trigger the Trip contacts</i>	Combination of (BI1, BI2, BI3, BI4, BI5, BI6, BI7, BI8, BI9, BI10, BI11, BI12, BI13, BI14, BI15, BI16, BI17, BI18, BI19, BI20, BI21, BI22, BI23, BI24, BI25, BI26, BI27, BI28, BI29, BI30, BI31, BI32, BI33, BI34, BI35, BI36, BI37, BI38, BI39, BI40, BI41, BI42, BI43, V1, V2, V3, V4, V5, V6, V7, V8, V9, V10, V11, V12, V13, V14)	----- ----- -----	
Trig Trip Contacts B <i>As Above</i>	Combination of (BI1, BI2, BI3, BI4, BI5, BI6, BI7, BI8, BI9, BI10, BI11, BI12, BI13, BI14, BI15, BI16, BI17, BI18, BI19, BI20, BI21, BI22, BI23, BI24, BI25, BI26, BI27, BI28, BI29, BI30, BI31, BI32, BI33, BI34, BI35, BI36, BI37, BI38, BI39, BI40, BI41, BI42, BI43, V1, V2, V3, V4, V5, V6, V7, V8, V9, V10, V11, V12, V13, V14)	----- ----- -----	
Trig Trip Contacts C <i>As Above</i>	Combination of (BI1, BI2, BI3, BI4, BI5, BI6, BI7, BI8, BI9, BI10, BI11, BI12, BI13, BI14, BI15, BI16, BI17, BI18, BI19, BI20, BI21, BI22, BI23, BI24, BI25, BI26, BI27, BI28, BI29, BI30, BI31, BI32, BI33, BI34, BI35, BI36, BI37, BI38, BI39, BI40, BI41, BI42, BI43, V1, V2, V3, V4, V5, V6, V7, V8, V9, V10, V11, V12, V13, V14)	----- ----- -----	
Inhibit 50BF <i>Selects which inputs inhibit the 50BF element</i>	Combination of (BI1, BI2, BI3, BI4, BI5, BI6, BI7, BI8, BI9, BI10, BI11, BI12, BI13, BI14, BI15, BI16, BI17, BI18, BI19, BI20, BI21, BI22, BI23, BI24, BI25, BI26, BI27, BI28, BI29, BI30, BI31, BI32, BI33, BI34, BI35, BI36, BI37, BI38, BI39, BI40, BI41, BI42, BI43, V1, V2, V3, V4, V5, V6, V7, V8, V9, V10, V11, V12, V13, V14)	----- ----- -----	
50BF-A Ext Trip <i>Selects which inputs can also start the 50BF element</i>	Combination of (BI1, BI2, BI3, BI4, BI5, BI6, BI7, BI8, BI9, BI10, BI11, BI12, BI13, BI14, BI15, BI16, BI17, BI18, BI19, BI20, BI21, BI22, BI23, BI24, BI25, BI26, BI27, BI28, BI29, BI30, BI31, BI32, BI33, BI34, BI35, BI36, BI37, BI38, BI39, BI40, BI41, BI42, BI43, V1, V2, V3, V4, V5, V6, V7, V8, V9, V10, V11, V12, V13, V14)	----- ----- -----	

Description	Range	Default	Setting
50BF-B Ext Trip <i>As Above</i>	Combination of (BI1, BI2, BI3, BI4, BI5, BI6, BI7, BI8, BI9, BI10, BI11, BI12, BI13, BI14, BI15, BI16, BI17, BI18, BI19, BI20, BI21, BI22, BI23, BI24, BI25, BI26, BI27, BI28, BI29, BI30, BI31, BI32, BI33, BI34, BI35, BI36, BI37, BI38, BI39, BI40, BI41, BI42, BI43, V1, V2, V3, V4, V5, V6, V7, V8, V9, V10, V11, V12, V13, V14)	----- ----- -----	
50BF-C Ext Trip <i>As Above</i>	Combination of (BI1, BI2, BI3, BI4, BI5, BI6, BI7, BI8, BI9, BI10, BI11, BI12, BI13, BI14, BI15, BI16, BI17, BI18, BI19, BI20, BI21, BI22, BI23, BI24, BI25, BI26, BI27, BI28, BI29, BI30, BI31, BI32, BI33, BI34, BI35, BI36, BI37, BI38, BI39, BI40, BI41, BI42, BI43, V1, V2, V3, V4, V5, V6, V7, V8, V9, V10, V11, V12, V13, V14)	----- ----- -----	
Inhibit 60VTS <i>Selects which inputs inhibit the VT Supervision element</i>	Combination of (BI1, BI2, BI3, BI4, BI5, BI6, BI7, BI8, BI9, BI10, BI11, BI12, BI13, BI14, BI15, BI16, BI17, BI18, BI19, BI20, BI21, BI22, BI23, BI24, BI25, BI26, BI27, BI28, BI29, BI30, BI31, BI32, BI33, BI34, BI35, BI36, BI37, BI38, BI39, BI40, BI41, BI42, BI43, V1, V2, V3, V4, V5, V6, V7, V8, V9, V10, V11, V12, V13, V14)	----- ----- -----	
Ext Trig 60VTS <i>Selects MCB inputs to VT Supervision element</i>	Combination of (BI1, BI2, BI3, BI4, BI5, BI6, BI7, BI8, BI9, BI10, BI11, BI12, BI13, BI14, BI15, BI16, BI17, BI18, BI19, BI20, BI21, BI22, BI23, BI24, BI25, BI26, BI27, BI28, BI29, BI30, BI31, BI32, BI33, BI34, BI35, BI36, BI37, BI38, BI39, BI40, BI41, BI42, BI43, V1, V2, V3, V4, V5, V6, V7, V8, V9, V10, V11, V12, V13, V14)	----- ----- -----	
Ext Reset 60VTS <i>Selects which inputs reset the VT Supervision element</i>	Combination of (BI1, BI2, BI3, BI4, BI5, BI6, BI7, BI8, BI9, BI10, BI11, BI12, BI13, BI14, BI15, BI16, BI17, BI18, BI19, BI20, BI21, BI22, BI23, BI24, BI25, BI26, BI27, BI28, BI29, BI30, BI31, BI32, BI33, BI34, BI35, BI36, BI37, BI38, BI39, BI40, BI41, BI42, BI43, V1, V2, V3, V4, V5, V6, V7, V8, V9, V10, V11, V12, V13, V14)	----- ----- -----	

Description	Range	Default	Setting
Reset CB-A TotalTrip <i>Selects which inputs Reset the CB Total Trip count</i>	Combination of (BI1, BI2, BI3, BI4, BI5, BI6, BI7, BI8, BI9, BI10, BI11, BI12, BI13, BI14, BI15, BI16, BI17, BI18, BI19, BI20, BI21, BI22, BI23, BI24, BI25, BI26, BI27, BI28, BI29, BI30, BI31, BI32, BI33, BI34, BI35, BI36, BI37, BI38, BI39, BI40, BI41, BI42, BI43, V1, V2, V3, V4, V5, V6, V7, V8, V9, V10, V11, V12, V13, V14)	----- ----- -----	
Reset CB-B TotalTrip <i>As Above</i>	Combination of (BI1, BI2, BI3, BI4, BI5, BI6, BI7, BI8, BI9, BI10, BI11, BI12, BI13, BI14, BI15, BI16, BI17, BI18, BI19, BI20, BI21, BI22, BI23, BI24, BI25, BI26, BI27, BI28, BI29, BI30, BI31, BI32, BI33, BI34, BI35, BI36, BI37, BI38, BI39, BI40, BI41, BI42, BI43, V1, V2, V3, V4, V5, V6, V7, V8, V9, V10, V11, V12, V13, V14)	----- ----- -----	
Reset CB-C TotalTrip <i>As Above</i>	Combination of (BI1, BI2, BI3, BI4, BI5, BI6, BI7, BI8, BI9, BI10, BI11, BI12, BI13, BI14, BI15, BI16, BI17, BI18, BI19, BI20, BI21, BI22, BI23, BI24, BI25, BI26, BI27, BI28, BI29, BI30, BI31, BI32, BI33, BI34, BI35, BI36, BI37, BI38, BI39, BI40, BI41, BI42, BI43, V1, V2, V3, V4, V5, V6, V7, V8, V9, V10, V11, V12, V13, V14)	----- ----- -----	
Reset CB-A DeltaTrip <i>Selects which inputs Reset the Delta CB Trip count</i>	Combination of (BI1, BI2, BI3, BI4, BI5, BI6, BI7, BI8, BI9, BI10, BI11, BI12, BI13, BI14, BI15, BI16, BI17, BI18, BI19, BI20, BI21, BI22, BI23, BI24, BI25, BI26, BI27, BI28, BI29, BI30, BI31, BI32, BI33, BI34, BI35, BI36, BI37, BI38, BI39, BI40, BI41, BI42, BI43, V1, V2, V3, V4, V5, V6, V7, V8, V9, V10, V11, V12, V13, V14)	----- ----- -----	
Reset CB-B DeltaTrip <i>As Above</i>	Combination of (BI1, BI2, BI3, BI4, BI5, BI6, BI7, BI8, BI9, BI10, BI11, BI12, BI13, BI14, BI15, BI16, BI17, BI18, BI19, BI20, BI21, BI22, BI23, BI24, BI25, BI26, BI27, BI28, BI29, BI30, BI31, BI32, BI33, BI34, BI35, BI36, BI37, BI38, BI39, BI40, BI41, BI42, BI43, V1, V2, V3, V4, V5, V6, V7, V8, V9, V10, V11, V12, V13, V14)	----- ----- -----	

Description	Range	Default	Setting
Reset CB-C DeltaTrip <i>As Above</i>	Combination of (BI1, BI2, BI3, BI4, BI5, BI6, BI7, BI8, BI9, BI10, BI11, BI12, BI13, BI14, BI15, BI16, BI17, BI18, BI19, BI20, BI21, BI22, BI23, BI24, BI25, BI26, BI27, BI28, BI29, BI30, BI31, BI32, BI33, BI34, BI35, BI36, BI37, BI38, BI39, BI40, BI41, BI42, BI43, V1, V2, V3, V4, V5, V6, V7, V8, V9, V10, V11, V12, V13, V14)	----- ----- -----	
ResetCB-A ARBlockCnt <i>Selects which inputs Reset the AR Block count</i>	Combination of (BI1, BI2, BI3, BI4, BI5, BI6, BI7, BI8, BI9, BI10, BI11, BI12, BI13, BI14, BI15, BI16, BI17, BI18, BI19, BI20, BI21, BI22, BI23, BI24, BI25, BI26, BI27, BI28, BI29, BI30, BI31, BI32, BI33, BI34, BI35, BI36, BI37, BI38, BI39, BI40, BI41, BI42, BI43, V1, V2, V3, V4, V5, V6, V7, V8, V9, V10, V11, V12, V13, V14)	----- ----- -----	
ResetCB-B ARBlockCnt <i>As Above</i>	Combination of (BI1, BI2, BI3, BI4, BI5, BI6, BI7, BI8, BI9, BI10, BI11, BI12, BI13, BI14, BI15, BI16, BI17, BI18, BI19, BI20, BI21, BI22, BI23, BI24, BI25, BI26, BI27, BI28, BI29, BI30, BI31, BI32, BI33, BI34, BI35, BI36, BI37, BI38, BI39, BI40, BI41, BI42, BI43, V1, V2, V3, V4, V5, V6, V7, V8, V9, V10, V11, V12, V13, V14)	----- ----- -----	
ResetCB-C ARBlockCnt <i>As Above</i>	Combination of (BI1, BI2, BI3, BI4, BI5, BI6, BI7, BI8, BI9, BI10, BI11, BI12, BI13, BI14, BI15, BI16, BI17, BI18, BI19, BI20, BI21, BI22, BI23, BI24, BI25, BI26, BI27, BI28, BI29, BI30, BI31, BI32, BI33, BI34, BI35, BI36, BI37, BI38, BI39, BI40, BI41, BI42, BI43, V1, V2, V3, V4, V5, V6, V7, V8, V9, V10, V11, V12, V13, V14)	----- ----- -----	
Reset CB-A Freq Ops <i>Selects which inputs Reset the Frequent Ops count</i>	Combination of (BI1, BI2, BI3, BI4, BI5, BI6, BI7, BI8, BI9, BI10, BI11, BI12, BI13, BI14, BI15, BI16, BI17, BI18, BI19, BI20, BI21, BI22, BI23, BI24, BI25, BI26, BI27, BI28, BI29, BI30, BI31, BI32, BI33, BI34, BI35, BI36, BI37, BI38, BI39, BI40, BI41, BI42, BI43, V1, V2, V3, V4, V5, V6, V7, V8, V9, V10, V11, V12, V13, V14)	----- ----- -----	

Description	Range	Default	Setting
Reset CB-B Freq Ops <i>As Above</i>	Combination of (BI1, BI2, BI3, BI4, BI5, BI6, BI7, BI8, BI9, BI10, BI11, BI12, BI13, BI14, BI15, BI16, BI17, BI18, BI19, BI20, BI21, BI22, BI23, BI24, BI25, BI26, BI27, BI28, BI29, BI30, BI31, BI32, BI33, BI34, BI35, BI36, BI37, BI38, BI39, BI40, BI41, BI42, BI43, V1, V2, V3, V4, V5, V6, V7, V8, V9, V10, V11, V12, V13, V14)	----- ----- -----	
Reset CB-C Freq Ops <i>As Above</i>	Combination of (BI1, BI2, BI3, BI4, BI5, BI6, BI7, BI8, BI9, BI10, BI11, BI12, BI13, BI14, BI15, BI16, BI17, BI18, BI19, BI20, BI21, BI22, BI23, BI24, BI25, BI26, BI27, BI28, BI29, BI30, BI31, BI32, BI33, BI34, BI35, BI36, BI37, BI38, BI39, BI40, BI41, BI42, BI43, V1, V2, V3, V4, V5, V6, V7, V8, V9, V10, V11, V12, V13, V14)	----- ----- -----	
Reset CB-A LO Count <i>Selects which inputs Reset the CB Lockout operations count</i>	Combination of (BI1, BI2, BI3, BI4, BI5, BI6, BI7, BI8, BI9, BI10, BI11, BI12, BI13, BI14, BI15, BI16, BI17, BI18, BI19, BI20, BI21, BI22, BI23, BI24, BI25, BI26, BI27, BI28, BI29, BI30, BI31, BI32, BI33, BI34, BI35, BI36, BI37, BI38, BI39, BI40, BI41, BI42, BI43, V1, V2, V3, V4, V5, V6, V7, V8, V9, V10, V11, V12, V13, V14)	----- ----- -----	
Reset CB-B LO Count <i>As Above</i>	Combination of (BI1, BI2, BI3, BI4, BI5, BI6, BI7, BI8, BI9, BI10, BI11, BI12, BI13, BI14, BI15, BI16, BI17, BI18, BI19, BI20, BI21, BI22, BI23, BI24, BI25, BI26, BI27, BI28, BI29, BI30, BI31, BI32, BI33, BI34, BI35, BI36, BI37, BI38, BI39, BI40, BI41, BI42, BI43, V1, V2, V3, V4, V5, V6, V7, V8, V9, V10, V11, V12, V13, V14)	----- ----- -----	
Reset CB-C LO Count <i>As Above</i>	Combination of (BI1, BI2, BI3, BI4, BI5, BI6, BI7, BI8, BI9, BI10, BI11, BI12, BI13, BI14, BI15, BI16, BI17, BI18, BI19, BI20, BI21, BI22, BI23, BI24, BI25, BI26, BI27, BI28, BI29, BI30, BI31, BI32, BI33, BI34, BI35, BI36, BI37, BI38, BI39, BI40, BI41, BI42, BI43, V1, V2, V3, V4, V5, V6, V7, V8, V9, V10, V11, V12, V13, V14)	----- ----- -----	

Description	Range	Default	Setting
Reset I ² t CB-A Wear <i>Selects which inputs Reset the I²t CB Wear element</i>	Combination of (BI1, BI2, BI3, BI4, BI5, BI6, BI7, BI8, BI9, BI10, BI11, BI12, BI13, BI14, BI15, BI16, BI17, BI18, BI19, BI20, BI21, BI22, BI23, BI24, BI25, BI26, BI27, BI28, BI29, BI30, BI31, BI32, BI33, BI34, BI35, BI36, BI37, BI38, BI39, BI40, BI41, BI42, BI43, V1, V2, V3, V4, V5, V6, V7, V8, V9, V10, V11, V12, V13, V14)	----- ----- -----	
Reset I ² t CB-B Wear <i>As Above</i>	Combination of (BI1, BI2, BI3, BI4, BI5, BI6, BI7, BI8, BI9, BI10, BI11, BI12, BI13, BI14, BI15, BI16, BI17, BI18, BI19, BI20, BI21, BI22, BI23, BI24, BI25, BI26, BI27, BI28, BI29, BI30, BI31, BI32, BI33, BI34, BI35, BI36, BI37, BI38, BI39, BI40, BI41, BI42, BI43, V1, V2, V3, V4, V5, V6, V7, V8, V9, V10, V11, V12, V13, V14)	----- ----- -----	
Reset I ² t CB-C Wear <i>As Above</i>	Combination of (BI1, BI2, BI3, BI4, BI5, BI6, BI7, BI8, BI9, BI10, BI11, BI12, BI13, BI14, BI15, BI16, BI17, BI18, BI19, BI20, BI21, BI22, BI23, BI24, BI25, BI26, BI27, BI28, BI29, BI30, BI31, BI32, BI33, BI34, BI35, BI36, BI37, BI38, BI39, BI40, BI41, BI42, BI43, V1, V2, V3, V4, V5, V6, V7, V8, V9, V10, V11, V12, V13, V14)	----- ----- -----	
Trig I ² t CB-A Wear <i>Selects which inputs will cause an external trigger of the I²t CB Wear element</i>	Combination of (BI1, BI2, BI3, BI4, BI5, BI6, BI7, BI8, BI9, BI10, BI11, BI12, BI13, BI14, BI15, BI16, BI17, BI18, BI19, BI20, BI21, BI22, BI23, BI24, BI25, BI26, BI27, BI28, BI29, BI30, BI31, BI32, BI33, BI34, BI35, BI36, BI37, BI38, BI39, BI40, BI41, BI42, BI43, V1, V2, V3, V4, V5, V6, V7, V8, V9, V10, V11, V12, V13, V14)	----- ----- -----	
Trig I ² t CB-B Wear <i>As Above</i>	Combination of (BI1, BI2, BI3, BI4, BI5, BI6, BI7, BI8, BI9, BI10, BI11, BI12, BI13, BI14, BI15, BI16, BI17, BI18, BI19, BI20, BI21, BI22, BI23, BI24, BI25, BI26, BI27, BI28, BI29, BI30, BI31, BI32, BI33, BI34, BI35, BI36, BI37, BI38, BI39, BI40, BI41, BI42, BI43, V1, V2, V3, V4, V5, V6, V7, V8, V9, V10, V11, V12, V13, V14)	----- ----- -----	

Description	Range	Default	Setting
Trig I ² t CB-C Wear As Above	Combination of (BI1, BI2, BI3, BI4, BI5, BI6, BI7, BI8, BI9, BI10, BI11, BI12, BI13, BI14, BI15, BI16, BI17, BI18, BI19, BI20, BI21, BI22, BI23, BI24, BI25, BI26, BI27, BI28, BI29, BI30, BI31, BI32, BI33, BI34, BI35, BI36, BI37, BI38, BI39, BI40, BI41, BI42, BI43, V1, V2, V3, V4, V5, V6, V7, V8, V9, V10, V11, V12, V13, V14)	----- ----- -----	
General Alarm 1 <i>Selects which inputs will activate the General Alarm 1 text</i>	Combination of (BI1, BI2, BI3, BI4, BI5, BI6, BI7, BI8, BI9, BI10, BI11, BI12, BI13, BI14, BI15, BI16, BI17, BI18, BI19, BI20, BI21, BI22, BI23, BI24, BI25, BI26, BI27, BI28, BI29, BI30, BI31, BI32, BI33, BI34, BI35, BI36, BI37, BI38, BI39, BI40, BI41, BI42, BI43, V1, V2, V3, V4, V5, V6, V7, V8, V9, V10, V11, V12, V13, V14)	----- ----- -----	
General Alarm 2 <i>Selects which inputs will activate the General Alarm 2 text</i>	Combination of (BI1, BI2, BI3, BI4, BI5, BI6, BI7, BI8, BI9, BI10, BI11, BI12, BI13, BI14, BI15, BI16, BI17, BI18, BI19, BI20, BI21, BI22, BI23, BI24, BI25, BI26, BI27, BI28, BI29, BI30, BI31, BI32, BI33, BI34, BI35, BI36, BI37, BI38, BI39, BI40, BI41, BI42, BI43, V1, V2, V3, V4, V5, V6, V7, V8, V9, V10, V11, V12, V13, V14)	----- ----- -----	
General Alarm 3 <i>Selects which inputs will activate the General Alarm 3 text</i>	Combination of (BI1, BI2, BI3, BI4, BI5, BI6, BI7, BI8, BI9, BI10, BI11, BI12, BI13, BI14, BI15, BI16, BI17, BI18, BI19, BI20, BI21, BI22, BI23, BI24, BI25, BI26, BI27, BI28, BI29, BI30, BI31, BI32, BI33, BI34, BI35, BI36, BI37, BI38, BI39, BI40, BI41, BI42, BI43, V1, V2, V3, V4, V5, V6, V7, V8, V9, V10, V11, V12, V13, V14)	----- ----- -----	
General Alarm 4 <i>Selects which inputs will activate the General Alarm 4 text</i>	Combination of (BI1, BI2, BI3, BI4, BI5, BI6, BI7, BI8, BI9, BI10, BI11, BI12, BI13, BI14, BI15, BI16, BI17, BI18, BI19, BI20, BI21, BI22, BI23, BI24, BI25, BI26, BI27, BI28, BI29, BI30, BI31, BI32, BI33, BI34, BI35, BI36, BI37, BI38, BI39, BI40, BI41, BI42, BI43, V1, V2, V3, V4, V5, V6, V7, V8, V9, V10, V11, V12, V13, V14)	----- ----- -----	

Description	Range	Default	Setting
<p>General Alarm 5 <i>Selects which inputs will activate the General Alarm 5 text</i></p>	<p>Combination of (BI1, BI2, BI3, BI4, BI5, BI6, BI7, BI8, BI9, BI10, BI11, BI12, BI13, BI14, BI15, BI16, BI17, BI18, BI19, BI20, BI21, BI22, BI23, BI24, BI25, BI26, BI27, BI28, BI29, BI30, BI31, BI32, BI33, BI34, BI35, BI36, BI37, BI38, BI39, BI40, BI41, BI42, BI43, V1, V2, V3, V4, V5, V6, V7, V8, V9, V10, V11, V12, V13, V14)</p>	<p>----- ----- -----</p>	
<p>General Alarm 6 <i>Selects which inputs will activate the General Alarm 6 text</i></p>	<p>Combination of (BI1, BI2, BI3, BI4, BI5, BI6, BI7, BI8, BI9, BI10, BI11, BI12, BI13, BI14, BI15, BI16, BI17, BI18, BI19, BI20, BI21, BI22, BI23, BI24, BI25, BI26, BI27, BI28, BI29, BI30, BI31, BI32, BI33, BI34, BI35, BI36, BI37, BI38, BI39, BI40, BI41, BI42, BI43, V1, V2, V3, V4, V5, V6, V7, V8, V9, V10, V11, V12, V13, V14)</p>	<p>----- ----- -----</p>	
<p>General Alarm 7 <i>Selects which inputs will activate the General Alarm 7 text</i></p>	<p>Combination of (BI1, BI2, BI3, BI4, BI5, BI6, BI7, BI8, BI9, BI10, BI11, BI12, BI13, BI14, BI15, BI16, BI17, BI18, BI19, BI20, BI21, BI22, BI23, BI24, BI25, BI26, BI27, BI28, BI29, BI30, BI31, BI32, BI33, BI34, BI35, BI36, BI37, BI38, BI39, BI40, BI41, BI42, BI43, V1, V2, V3, V4, V5, V6, V7, V8, V9, V10, V11, V12, V13, V14)</p>	<p>----- ----- -----</p>	
<p>General Alarm 8 <i>Selects which inputs will activate the General Alarm 8 text</i></p>	<p>Combination of (BI1, BI2, BI3, BI4, BI5, BI6, BI7, BI8, BI9, BI10, BI11, BI12, BI13, BI14, BI15, BI16, BI17, BI18, BI19, BI20, BI21, BI22, BI23, BI24, BI25, BI26, BI27, BI28, BI29, BI30, BI31, BI32, BI33, BI34, BI35, BI36, BI37, BI38, BI39, BI40, BI41, BI42, BI43, V1, V2, V3, V4, V5, V6, V7, V8, V9, V10, V11, V12, V13, V14)</p>	<p>----- ----- -----</p>	
<p>General Alarm 9 <i>Selects which inputs will activate the General Alarm 9 text</i></p>	<p>Combination of (BI1, BI2, BI3, BI4, BI5, BI6, BI7, BI8, BI9, BI10, BI11, BI12, BI13, BI14, BI15, BI16, BI17, BI18, BI19, BI20, BI21, BI22, BI23, BI24, BI25, BI26, BI27, BI28, BI29, BI30, BI31, BI32, BI33, BI34, BI35, BI36, BI37, BI38, BI39, BI40, BI41, BI42, BI43, V1, V2, V3, V4, V5, V6, V7, V8, V9, V10, V11, V12, V13, V14)</p>	<p>----- ----- -----</p>	

Description	Range	Default	Setting
General Alarm 10 <i>Selects which inputs will activate the General Alarm 10 text</i>	Combination of (BI1, BI2, BI3, BI4, BI5, BI6, BI7, BI8, BI9, BI10, BI11, BI12, BI13, BI14, BI15, BI16, BI17, BI18, BI19, BI20, BI21, BI22, BI23, BI24, BI25, BI26, BI27, BI28, BI29, BI30, BI31, BI32, BI33, BI34, BI35, BI36, BI37, BI38, BI39, BI40, BI41, BI42, BI43, V1, V2, V3, V4, V5, V6, V7, V8, V9, V10, V11, V12, V13, V14)	----- ----- -----	
General Alarm 11 <i>Selects which inputs will activate the General Alarm 11 text</i>	Combination of (BI1, BI2, BI3, BI4, BI5, BI6, BI7, BI8, BI9, BI10, BI11, BI12, BI13, BI14, BI15, BI16, BI17, BI18, BI19, BI20, BI21, BI22, BI23, BI24, BI25, BI26, BI27, BI28, BI29, BI30, BI31, BI32, BI33, BI34, BI35, BI36, BI37, BI38, BI39, BI40, BI41, BI42, BI43, V1, V2, V3, V4, V5, V6, V7, V8, V9, V10, V11, V12, V13, V14)	----- ----- -----	
General Alarm 12 <i>Selects which inputs will activate the General Alarm 12 text</i>	Combination of (BI1, BI2, BI3, BI4, BI5, BI6, BI7, BI8, BI9, BI10, BI11, BI12, BI13, BI14, BI15, BI16, BI17, BI18, BI19, BI20, BI21, BI22, BI23, BI24, BI25, BI26, BI27, BI28, BI29, BI30, BI31, BI32, BI33, BI34, BI35, BI36, BI37, BI38, BI39, BI40, BI41, BI42, BI43, V1, V2, V3, V4, V5, V6, V7, V8, V9, V10, V11, V12, V13, V14)	----- ----- -----	
BatteryTestRequired <i>Selects which inputs will initiate a Battery test</i>	Combination of (BI1, BI2, BI3, BI4, BI5, BI6, BI7, BI8, BI9, BI10, BI11, BI12, BI13, BI14, BI15, BI16, BI17, BI18, BI19, BI20, BI21, BI22, BI23, BI24, BI25, BI26, BI27, BI28, BI29, BI30, BI31, BI32, BI33, BI34, BI35, BI36, BI37, BI38, BI39, BI40, BI41, BI42, BI43, V1, V2, V3, V4, V5, V6, V7, V8, V9, V10, V11, V12, V13, V14)	----- ----- -----	
ExtPowerGood <i>Selects which inputs are used to indicate External power to battery is good.</i>	Combination of (BI1, BI2, BI3, BI4, BI5, BI6, BI7, BI8, BI9, BI10, BI11, BI12, BI13, BI14, BI15, BI16, BI17, BI18, BI19, BI20, BI21, BI22, BI23, BI24, BI25, BI26, BI27, BI28, BI29, BI30, BI31, BI32, BI33, BI34, BI35, BI36, BI37, BI38, BI39, BI40, BI41, BI42, BI43, V1, V2, V3, V4, V5, V6, V7, V8, V9, V10, V11, V12, V13, V14)	----- ----- -----	

Description	Range	Default	Setting
InhibitBatteryTest <i>Selects which inputs will inhibit a Battery test.</i>	Combination of (BI1, BI2, BI3, BI4, BI5, BI6, BI7, BI8, BI9, BI10, BI11, BI12, BI13, BI14, BI15, BI16, BI17, BI18, BI19, BI20, BI21, BI22, BI23, BI24, BI25, BI26, BI27, BI28, BI29, BI30, BI31, BI32, BI33, BI34, BI35, BI36, BI37, BI38, BI39, BI40, BI41, BI42, BI43, V1, V2, V3, V4, V5, V6, V7, V8, V9, V10, V11, V12, V13, V14)	----- ----- -----	
Capacitor Test <i>Selects which inputs will initiate a Capacitor test.</i>	Combination of (BI1, BI2, BI3, BI4, BI5, BI6, BI7, BI8, BI9, BI10, BI11, BI12, BI13, BI14, BI15, BI16, BI17, BI18, BI19, BI20, BI21, BI22, BI23, BI24, BI25, BI26, BI27, BI28, BI29, BI30, BI31, BI32, BI33, BI34, BI35, BI36, BI37, BI38, BI39, BI40, BI41, BI42, BI43, V1, V2, V3, V4, V5, V6, V7, V8, V9, V10, V11, V12, V13, V14)	----- ----- -----	
Cap-A Mon Input 1 <i>Selects which inputs will monitor Capacitor level 1.</i>	Combination of (BI1, BI2, BI3, BI4, BI5, BI6, BI7, BI8, BI9, BI10, BI11, BI12, BI13, BI14, BI15, BI16, BI17, BI18, BI19, BI20, BI21, BI22, BI23, BI24, BI25, BI26, BI27, BI28, BI29, BI30, BI31, BI32, BI33, BI34, BI35, BI36, BI37, BI38, BI39, BI40, BI41, BI42, BI43, V1, V2, V3, V4, V5, V6, V7, V8, V9, V10, V11, V12, V13, V14)	----- ----- -----	
Cap-A Mon Input 2 <i>Selects which inputs will monitor Capacitor level 2.</i>	Combination of (BI1, BI2, BI3, BI4, BI5, BI6, BI7, BI8, BI9, BI10, BI11, BI12, BI13, BI14, BI15, BI16, BI17, BI18, BI19, BI20, BI21, BI22, BI23, BI24, BI25, BI26, BI27, BI28, BI29, BI30, BI31, BI32, BI33, BI34, BI35, BI36, BI37, BI38, BI39, BI40, BI41, BI42, BI43, V1, V2, V3, V4, V5, V6, V7, V8, V9, V10, V11, V12, V13, V14)	----- ----- -----	
Inhibit Cap-A Test <i>Selects which inputs will inhibit a Capacitor test.</i>	Combination of (BI1, BI2, BI3, BI4, BI5, BI6, BI7, BI8, BI9, BI10, BI11, BI12, BI13, BI14, BI15, BI16, BI17, BI18, BI19, BI20, BI21, BI22, BI23, BI24, BI25, BI26, BI27, BI28, BI29, BI30, BI31, BI32, BI33, BI34, BI35, BI36, BI37, BI38, BI39, BI40, BI41, BI42, BI43, V1, V2, V3, V4, V5, V6, V7, V8, V9, V10, V11, V12, V13, V14)	----- ----- -----	

Description	Range	Default	Setting
Cap-B Mon Input 1 <i>Selects which inputs will monitor Capacitor level 1.</i>	Combination of (BI1, BI2, BI3, BI4, BI5, BI6, BI7, BI8, BI9, BI10, BI11, BI12, BI13, BI14, BI15, BI16, BI17, BI18, BI19, BI20, BI21, BI22, BI23, BI24, BI25, BI26, BI27, BI28, BI29, BI30, BI31, BI32, BI33, BI34, BI35, BI36, BI37, BI38, BI39, BI40, BI41, BI42, BI43, V1, V2, V3, V4, V5, V6, V7, V8, V9, V10, V11, V12, V13, V14)	----- ----- -----	
Cap-B Mon Input 2 <i>Selects which inputs will monitor Capacitor level 2.</i>	Combination of (BI1, BI2, BI3, BI4, BI5, BI6, BI7, BI8, BI9, BI10, BI11, BI12, BI13, BI14, BI15, BI16, BI17, BI18, BI19, BI20, BI21, BI22, BI23, BI24, BI25, BI26, BI27, BI28, BI29, BI30, BI31, BI32, BI33, BI34, BI35, BI36, BI37, BI38, BI39, BI40, BI41, BI42, BI43, V1, V2, V3, V4, V5, V6, V7, V8, V9, V10, V11, V12, V13, V14)	----- ----- -----	
Inhibit Cap-B Test <i>Selects which inputs will inhibit a Capacitor test.</i>	Combination of (BI1, BI2, BI3, BI4, BI5, BI6, BI7, BI8, BI9, BI10, BI11, BI12, BI13, BI14, BI15, BI16, BI17, BI18, BI19, BI20, BI21, BI22, BI23, BI24, BI25, BI26, BI27, BI28, BI29, BI30, BI31, BI32, BI33, BI34, BI35, BI36, BI37, BI38, BI39, BI40, BI41, BI42, BI43, V1, V2, V3, V4, V5, V6, V7, V8, V9, V10, V11, V12, V13, V14)	----- ----- -----	
Cap-C Mon Input 1 <i>Selects which inputs will monitor Capacitor level 1.</i>	Combination of (BI1, BI2, BI3, BI4, BI5, BI6, BI7, BI8, BI9, BI10, BI11, BI12, BI13, BI14, BI15, BI16, BI17, BI18, BI19, BI20, BI21, BI22, BI23, BI24, BI25, BI26, BI27, BI28, BI29, BI30, BI31, BI32, BI33, BI34, BI35, BI36, BI37, BI38, BI39, BI40, BI41, BI42, BI43, V1, V2, V3, V4, V5, V6, V7, V8, V9, V10, V11, V12, V13, V14)	----- ----- -----	
Cap-C Mon Input 2 <i>Selects which inputs will monitor Capacitor level 2.</i>	Combination of (BI1, BI2, BI3, BI4, BI5, BI6, BI7, BI8, BI9, BI10, BI11, BI12, BI13, BI14, BI15, BI16, BI17, BI18, BI19, BI20, BI21, BI22, BI23, BI24, BI25, BI26, BI27, BI28, BI29, BI30, BI31, BI32, BI33, BI34, BI35, BI36, BI37, BI38, BI39, BI40, BI41, BI42, BI43, V1, V2, V3, V4, V5, V6, V7, V8, V9, V10, V11, V12, V13, V14)	----- ----- -----	

Description	Range	Default	Setting
Inhibit Cap-C Test <i>Selects which inputs will inhibit a Capacitor test.</i>	Combination of (BI1, BI2, BI3, BI4, BI5, BI6, BI7, BI8, BI9, BI10, BI11, BI12, BI13, BI14, BI15, BI16, BI17, BI18, BI19, BI20, BI21, BI22, BI23, BI24, BI25, BI26, BI27, BI28, BI29, BI30, BI31, BI32, BI33, BI34, BI35, BI36, BI37, BI38, BI39, BI40, BI41, BI42, BI43, V1, V2, V3, V4, V5, V6, V7, V8, V9, V10, V11, V12, V13, V14)	----- ----- -----	
Reset SagSwell Count <i>Selects which inputs will reset the 27Sag & 59Swell counts.</i>	Combination of (BI1, BI2, BI3, BI4, BI5, BI6, BI7, BI8, BI9, BI10, BI11, BI12, BI13, BI14, BI15, BI16, BI17, BI18, BI19, BI20, BI21, BI22, BI23, BI24, BI25, BI26, BI27, BI28, BI29, BI30, BI31, BI32, BI33, BI34, BI35, BI36, BI37, BI38, BI39, BI40, BI41, BI42, BI43, V1, V2, V3, V4, V5, V6, V7, V8, V9, V10, V11, V12, V13, V14)	----- ----- -----	
Inhibit 27Sag <i>Selects which inputs will inhibit the 27Sag elements.</i>	Combination of (BI1, BI2, BI3, BI4, BI5, BI6, BI7, BI8, BI9, BI10, BI11, BI12, BI13, BI14, BI15, BI16, BI17, BI18, BI19, BI20, BI21, BI22, BI23, BI24, BI25, BI26, BI27, BI28, BI29, BI30, BI31, BI32, BI33, BI34, BI35, BI36, BI37, BI38, BI39, BI40, BI41, BI42, BI43, V1, V2, V3, V4, V5, V6, V7, V8, V9, V10, V11, V12, V13, V14)	----- ----- -----	
Inhibit 59Swell <i>Selects which inputs will inhibit the 59Swell elements.</i>	Combination of (BI1, BI2, BI3, BI4, BI5, BI6, BI7, BI8, BI9, BI10, BI11, BI12, BI13, BI14, BI15, BI16, BI17, BI18, BI19, BI20, BI21, BI22, BI23, BI24, BI25, BI26, BI27, BI28, BI29, BI30, BI31, BI32, BI33, BI34, BI35, BI36, BI37, BI38, BI39, BI40, BI41, BI42, BI43, V1, V2, V3, V4, V5, V6, V7, V8, V9, V10, V11, V12, V13, V14)	----- ----- -----	
Reset Demand <i>Selects which inputs will rest the Demand elements.</i>	Combination of (BI1, BI2, BI3, BI4, BI5, BI6, BI7, BI8, BI9, BI10, BI11, BI12, BI13, BI14, BI15, BI16, BI17, BI18, BI19, BI20, BI21, BI22, BI23, BI24, BI25, BI26, BI27, BI28, BI29, BI30, BI31, BI32, BI33, BI34, BI35, BI36, BI37, BI38, BI39, BI40, BI41, BI42, BI43, V1, V2, V3, V4, V5, V6, V7, V8, V9, V10, V11, V12, V13, V14)	----- ----- -----	

Description	Range	Default	Setting
<p>Mode A - 3PTrip3PLO <i>Selects which inputs will Set the relay to operate in Mode A (3 pole Trip & 3 pole lockout).</i></p>	<p>Combination of (BI1, BI2, BI3, BI4, BI5, BI6, BI7, BI8, BI9, BI10, BI11, BI12, BI13, BI14, BI15, BI16, BI17, BI18, BI19, BI20, BI21, BI22, BI23, BI24, BI25, BI26, BI27, BI28, BI29, BI30, BI31, BI32, BI33, BI34, BI35, BI36, BI37, BI38, BI39, BI40, BI41, BI42, BI43, V1, V2, V3, V4, V5, V6, V7, V8, V9, V10, V11, V12, V13, V14)</p>	<p>----- ----- -----</p>	
<p>Mode B - 1PTrip3PLO <i>Selects which inputs will Set the relay to operate in Mode B (1 pole Trip & 3 pole lockout).</i></p>	<p>Combination of (BI1, BI2, BI3, BI4, BI5, BI6, BI7, BI8, BI9, BI10, BI11, BI12, BI13, BI14, BI15, BI16, BI17, BI18, BI19, BI20, BI21, BI22, BI23, BI24, BI25, BI26, BI27, BI28, BI29, BI30, BI31, BI32, BI33, BI34, BI35, BI36, BI37, BI38, BI39, BI40, BI41, BI42, BI43, V1, V2, V3, V4, V5, V6, V7, V8, V9, V10, V11, V12, V13, V14)</p>	<p>----- ----- -----</p>	
<p>Mode C - 1PTrip1PLO <i>Selects which inputs will Set the relay to operate in Mode C (1 pole Trip & 1 pole lockout).</i></p>	<p>Combination of (BI1, BI2, BI3, BI4, BI5, BI6, BI7, BI8, BI9, BI10, BI11, BI12, BI13, BI14, BI15, BI16, BI17, BI18, BI19, BI20, BI21, BI22, BI23, BI24, BI25, BI26, BI27, BI28, BI29, BI30, BI31, BI32, BI33, BI34, BI35, BI36, BI37, BI38, BI39, BI40, BI41, BI42, BI43, V1, V2, V3, V4, V5, V6, V7, V8, V9, V10, V11, V12, V13, V14)</p>	<p>----- ----- -----</p>	
<p>Close CB-A <i>Selects which inputs will issue a close to the circuit breaker.</i></p>	<p>Combination of (BI1, BI2, BI3, BI4, BI5, BI6, BI7, BI8, BI9, BI10, BI11, BI12, BI13, BI14, BI15, BI16, BI17, BI18, BI19, BI20, BI21, BI22, BI23, BI24, BI25, BI26, BI27, BI28, BI29, BI30, BI31, BI32, BI33, BI34, BI35, BI36, BI37, BI38, BI39, BI40, BI41, BI42, BI43, V1, V2, V3, V4, V5, V6, V7, V8, V9, V10, V11, V12, V13, V14)</p>	<p>----- ----- -----</p>	
<p>Block Close CB-A <i>Selects which inputs will block the manual closing of the circuit breaker.</i></p>	<p>Combination of (BI1, BI2, BI3, BI4, BI5, BI6, BI7, BI8, BI9, BI10, BI11, BI12, BI13, BI14, BI15, BI16, BI17, BI18, BI19, BI20, BI21, BI22, BI23, BI24, BI25, BI26, BI27, BI28, BI29, BI30, BI31, BI32, BI33, BI34, BI35, BI36, BI37, BI38, BI39, BI40, BI41, BI42, BI43, V1, V2, V3, V4, V5, V6, V7, V8, V9, V10, V11, V12, V13, V14)</p>	<p>----- ----- -----</p>	

Description	Range	Default	Setting
<p>Open CB-A <i>Selects which inputs will issue an open to the circuit breaker.</i></p>	<p>Combination of (BI1, BI2, BI3, BI4, BI5, BI6, BI7, BI8, BI9, BI10, BI11, BI12, BI13, BI14, BI15, BI16, BI17, BI18, BI19, BI20, BI21, BI22, BI23, BI24, BI25, BI26, BI27, BI28, BI29, BI30, BI31, BI32, BI33, BI34, BI35, BI36, BI37, BI38, BI39, BI40, BI41, BI42, BI43, V1, V2, V3, V4, V5, V6, V7, V8, V9, V10, V11, V12, V13, V14)</p>	<p>----- ----- -----</p>	
<p>CB-A Closed <i>Selects which inputs are connected to the circuit breaker closed contacts</i></p>	<p>Combination of (BI1, BI2, BI3, BI4, BI5, BI6, BI7, BI8, BI9, BI10, BI11, BI12, BI13, BI14, BI15, BI16, BI17, BI18, BI19, BI20, BI21, BI22, BI23, BI24, BI25, BI26, BI27, BI28, BI29, BI30, BI31, BI32, BI33, BI34, BI35, BI36, BI37, BI38, BI39, BI40, BI41, BI42, BI43, V1, V2, V3, V4, V5, V6, V7, V8, V9, V10, V11, V12, V13, V14)</p>	<p>----- ----- -----</p>	
<p>CB-A Open <i>Selects which inputs are connected to the circuit breaker open contacts</i></p>	<p>Combination of (BI1, BI2, BI3, BI4, BI5, BI6, BI7, BI8, BI9, BI10, BI11, BI12, BI13, BI14, BI15, BI16, BI17, BI18, BI19, BI20, BI21, BI22, BI23, BI24, BI25, BI26, BI27, BI28, BI29, BI30, BI31, BI32, BI33, BI34, BI35, BI36, BI37, BI38, BI39, BI40, BI41, BI42, BI43, V1, V2, V3, V4, V5, V6, V7, V8, V9, V10, V11, V12, V13, V14)</p>	<p>----- ----- -----</p>	
<p>Close CB-B <i>Selects which inputs will issue a close to the circuit breaker.</i></p>	<p>Combination of (BI1, BI2, BI3, BI4, BI5, BI6, BI7, BI8, BI9, BI10, BI11, BI12, BI13, BI14, BI15, BI16, BI17, BI18, BI19, BI20, BI21, BI22, BI23, BI24, BI25, BI26, BI27, BI28, BI29, BI30, BI31, BI32, BI33, BI34, BI35, BI36, BI37, BI38, BI39, BI40, BI41, BI42, BI43, V1, V2, V3, V4, V5, V6, V7, V8, V9, V10, V11, V12, V13, V14)</p>	<p>----- ----- -----</p>	
<p>Block Close CB-B <i>Selects which inputs will block the manual closing of the circuit breaker.</i></p>	<p>Combination of (BI1, BI2, BI3, BI4, BI5, BI6, BI7, BI8, BI9, BI10, BI11, BI12, BI13, BI14, BI15, BI16, BI17, BI18, BI19, BI20, BI21, BI22, BI23, BI24, BI25, BI26, BI27, BI28, BI29, BI30, BI31, BI32, BI33, BI34, BI35, BI36, BI37, BI38, BI39, BI40, BI41, BI42, BI43, V1, V2, V3, V4, V5, V6, V7, V8, V9, V10, V11, V12, V13, V14)</p>	<p>----- ----- -----</p>	

Description	Range	Default	Setting
<p>Open CB-B <i>Selects which inputs will issue an open to the circuit breaker.</i></p>	<p>Combination of (BI1, BI2, BI3, BI4, BI5, BI6, BI7, BI8, BI9, BI10, BI11, BI12, BI13, BI14, BI15, BI16, BI17, BI18, BI19, BI20, BI21, BI22, BI23, BI24, BI25, BI26, BI27, BI28, BI29, BI30, BI31, BI32, BI33, BI34, BI35, BI36, BI37, BI38, BI39, BI40, BI41, BI42, BI43, V1, V2, V3, V4, V5, V6, V7, V8, V9, V10, V11, V12, V13, V14)</p>	<p>----- ----- -----</p>	
<p>CB-B Closed <i>Selects which inputs are connected to the circuit breaker closed contacts</i></p>	<p>Combination of (BI1, BI2, BI3, BI4, BI5, BI6, BI7, BI8, BI9, BI10, BI11, BI12, BI13, BI14, BI15, BI16, BI17, BI18, BI19, BI20, BI21, BI22, BI23, BI24, BI25, BI26, BI27, BI28, BI29, BI30, BI31, BI32, BI33, BI34, BI35, BI36, BI37, BI38, BI39, BI40, BI41, BI42, BI43, V1, V2, V3, V4, V5, V6, V7, V8, V9, V10, V11, V12, V13, V14)</p>	<p>----- ----- -----</p>	
<p>CB-B Open <i>Selects which inputs are connected to the circuit breaker open contacts</i></p>	<p>Combination of (BI1, BI2, BI3, BI4, BI5, BI6, BI7, BI8, BI9, BI10, BI11, BI12, BI13, BI14, BI15, BI16, BI17, BI18, BI19, BI20, BI21, BI22, BI23, BI24, BI25, BI26, BI27, BI28, BI29, BI30, BI31, BI32, BI33, BI34, BI35, BI36, BI37, BI38, BI39, BI40, BI41, BI42, BI43, V1, V2, V3, V4, V5, V6, V7, V8, V9, V10, V11, V12, V13, V14)</p>	<p>----- ----- -----</p>	
<p>Close CB-C <i>Selects which inputs will issue a close to the circuit breaker.</i></p>	<p>Combination of (BI1, BI2, BI3, BI4, BI5, BI6, BI7, BI8, BI9, BI10, BI11, BI12, BI13, BI14, BI15, BI16, BI17, BI18, BI19, BI20, BI21, BI22, BI23, BI24, BI25, BI26, BI27, BI28, BI29, BI30, BI31, BI32, BI33, BI34, BI35, BI36, BI37, BI38, BI39, BI40, BI41, BI42, BI43, V1, V2, V3, V4, V5, V6, V7, V8, V9, V10, V11, V12, V13, V14)</p>	<p>----- ----- -----</p>	
<p>Block Close CB-C <i>Selects which inputs will block the manual closing of the circuit breaker.</i></p>	<p>Combination of (BI1, BI2, BI3, BI4, BI5, BI6, BI7, BI8, BI9, BI10, BI11, BI12, BI13, BI14, BI15, BI16, BI17, BI18, BI19, BI20, BI21, BI22, BI23, BI24, BI25, BI26, BI27, BI28, BI29, BI30, BI31, BI32, BI33, BI34, BI35, BI36, BI37, BI38, BI39, BI40, BI41, BI42, BI43, V1, V2, V3, V4, V5, V6, V7, V8, V9, V10, V11, V12, V13, V14)</p>	<p>----- ----- -----</p>	

Description	Range	Default	Setting
<p>Open CB-C <i>Selects which inputs will issue an open to the circuit breaker.</i></p>	<p>Combination of (BI1, BI2, BI3, BI4, BI5, BI6, BI7, BI8, BI9, BI10, BI11, BI12, BI13, BI14, BI15, BI16, BI17, BI18, BI19, BI20, BI21, BI22, BI23, BI24, BI25, BI26, BI27, BI28, BI29, BI30, BI31, BI32, BI33, BI34, BI35, BI36, BI37, BI38, BI39, BI40, BI41, BI42, BI43, V1, V2, V3, V4, V5, V6, V7, V8, V9, V10, V11, V12, V13, V14)</p>	<p>----- ----- -----</p>	
<p>CB-C Closed <i>Selects which inputs are connected to the circuit breaker closed contacts</i></p>	<p>Combination of (BI1, BI2, BI3, BI4, BI5, BI6, BI7, BI8, BI9, BI10, BI11, BI12, BI13, BI14, BI15, BI16, BI17, BI18, BI19, BI20, BI21, BI22, BI23, BI24, BI25, BI26, BI27, BI28, BI29, BI30, BI31, BI32, BI33, BI34, BI35, BI36, BI37, BI38, BI39, BI40, BI41, BI42, BI43, V1, V2, V3, V4, V5, V6, V7, V8, V9, V10, V11, V12, V13, V14)</p>	<p>----- ----- -----</p>	
<p>CB-C Open <i>Selects which inputs are connected to the circuit breaker open contacts</i></p>	<p>Combination of (BI1, BI2, BI3, BI4, BI5, BI6, BI7, BI8, BI9, BI10, BI11, BI12, BI13, BI14, BI15, BI16, BI17, BI18, BI19, BI20, BI21, BI22, BI23, BI24, BI25, BI26, BI27, BI28, BI29, BI30, BI31, BI32, BI33, BI34, BI35, BI36, BI37, BI38, BI39, BI40, BI41, BI42, BI43, V1, V2, V3, V4, V5, V6, V7, V8, V9, V10, V11, V12, V13, V14)</p>	<p>----- ----- -----</p>	
<p>79 Out <i>Selects which inputs will switch the Auto-recloser out of service</i></p>	<p>Combination of (BI1, BI2, BI3, BI4, BI5, BI6, BI7, BI8, BI9, BI10, BI11, BI12, BI13, BI14, BI15, BI16, BI17, BI18, BI19, BI20, BI21, BI22, BI23, BI24, BI25, BI26, BI27, BI28, BI29, BI30, BI31, BI32, BI33, BI34, BI35, BI36, BI37, BI38, BI39, BI40, BI41, BI42, BI43, V1, V2, V3, V4, V5, V6, V7, V8, V9, V10, V11, V12, V13, V14)</p>	<p>----- ----- -----</p>	
<p>79 In <i>Selects which inputs will switch the Auto-recloser in service</i></p>	<p>Combination of (BI1, BI2, BI3, BI4, BI5, BI6, BI7, BI8, BI9, BI10, BI11, BI12, BI13, BI14, BI15, BI16, BI17, BI18, BI19, BI20, BI21, BI22, BI23, BI24, BI25, BI26, BI27, BI28, BI29, BI30, BI31, BI32, BI33, BI34, BI35, BI36, BI37, BI38, BI39, BI40, BI41, BI42, BI43, V1, V2, V3, V4, V5, V6, V7, V8, V9, V10, V11, V12, V13, V14)</p>	<p>----- ----- -----</p>	

Description	Range	Default	Setting
<p>79 Trip & Reclose <i>Selects which inputs will trigger a trip & reclose</i></p>	<p>Combination of (BI1, BI2, BI3, BI4, BI5, BI6, BI7, BI8, BI9, BI10, BI11, BI12, BI13, BI14, BI15, BI16, BI17, BI18, BI19, BI20, BI21, BI22, BI23, BI24, BI25, BI26, BI27, BI28, BI29, BI30, BI31, BI32, BI33, BI34, BI35, BI36, BI37, BI38, BI39, BI40, BI41, BI42, BI43, V1, V2, V3, V4, V5, V6, V7, V8, V9, V10, V11, V12, V13, V14)</p>	<p>----- ----- -----</p>	
<p>79 Trip & Lockout A <i>Selects which inputs will trigger a trip & lockout</i></p>	<p>Combination of (BI1, BI2, BI3, BI4, BI5, BI6, BI7, BI8, BI9, BI10, BI11, BI12, BI13, BI14, BI15, BI16, BI17, BI18, BI19, BI20, BI21, BI22, BI23, BI24, BI25, BI26, BI27, BI28, BI29, BI30, BI31, BI32, BI33, BI34, BI35, BI36, BI37, BI38, BI39, BI40, BI41, BI42, BI43, V1, V2, V3, V4, V5, V6, V7, V8, V9, V10, V11, V12, V13, V14)</p>	<p>----- ----- -----</p>	
<p>79 Trip & Lockout B <i>As Above</i></p>	<p>Combination of (BI1, BI2, BI3, BI4, BI5, BI6, BI7, BI8, BI9, BI10, BI11, BI12, BI13, BI14, BI15, BI16, BI17, BI18, BI19, BI20, BI21, BI22, BI23, BI24, BI25, BI26, BI27, BI28, BI29, BI30, BI31, BI32, BI33, BI34, BI35, BI36, BI37, BI38, BI39, BI40, BI41, BI42, BI43, V1, V2, V3, V4, V5, V6, V7, V8, V9, V10, V11, V12, V13, V14)</p>	<p>----- ----- -----</p>	
<p>79 Trip & Lockout C <i>As Above</i></p>	<p>Combination of (BI1, BI2, BI3, BI4, BI5, BI6, BI7, BI8, BI9, BI10, BI11, BI12, BI13, BI14, BI15, BI16, BI17, BI18, BI19, BI20, BI21, BI22, BI23, BI24, BI25, BI26, BI27, BI28, BI29, BI30, BI31, BI32, BI33, BI34, BI35, BI36, BI37, BI38, BI39, BI40, BI41, BI42, BI43, V1, V2, V3, V4, V5, V6, V7, V8, V9, V10, V11, V12, V13, V14)</p>	<p>----- ----- -----</p>	
<p>79 Ext Trip <i>Selects which input will start the external an Auto-relose sequence</i></p>	<p>Combination of (BI1, BI2, BI3, BI4, BI5, BI6, BI7, BI8, BI9, BI10, BI11, BI12, BI13, BI14, BI15, BI16, BI17, BI18, BI19, BI20, BI21, BI22, BI23, BI24, BI25, BI26, BI27, BI28, BI29, BI30, BI31, BI32, BI33, BI34, BI35, BI36, BI37, BI38, BI39, BI40, BI41, BI42, BI43, V1, V2, V3, V4, V5, V6, V7, V8, V9, V10, V11, V12, V13, V14)</p>	<p>----- ----- -----</p>	

Description	Range	Default	Setting
<p>79 Ext Pickup <i>Selects which input should be connected to the pickup of the external elements required to start an Auto-reclose sequence</i></p>	<p>Combination of (BI1, BI2, BI3, BI4, BI5, BI6, BI7, BI8, BI9, BI10, BI11, BI12, BI13, BI14, BI15, BI16, BI17, BI18, BI19, BI20, BI21, BI22, BI23, BI24, BI25, BI26, BI27, BI28, BI29, BI30, BI31, BI32, BI33, BI34, BI35, BI36, BI37, BI38, BI39, BI40, BI41, BI42, BI43, V1, V2, V3, V4, V5, V6, V7, V8, V9, V10, V11, V12, V13, V14)</p>	<p>----- ----- -----</p>	
<p>79 Block Reclose A <i>Selects which inputs will block the Auto-recloser</i></p>	<p>Combination of (BI1, BI2, BI3, BI4, BI5, BI6, BI7, BI8, BI9, BI10, BI11, BI12, BI13, BI14, BI15, BI16, BI17, BI18, BI19, BI20, BI21, BI22, BI23, BI24, BI25, BI26, BI27, BI28, BI29, BI30, BI31, BI32, BI33, BI34, BI35, BI36, BI37, BI38, BI39, BI40, BI41, BI42, BI43, V1, V2, V3, V4, V5, V6, V7, V8, V9, V10, V11, V12, V13, V14)</p>	<p>----- ----- -----</p>	
<p>79 Block Reclose B <i>As Above</i></p>	<p>Combination of (BI1, BI2, BI3, BI4, BI5, BI6, BI7, BI8, BI9, BI10, BI11, BI12, BI13, BI14, BI15, BI16, BI17, BI18, BI19, BI20, BI21, BI22, BI23, BI24, BI25, BI26, BI27, BI28, BI29, BI30, BI31, BI32, BI33, BI34, BI35, BI36, BI37, BI38, BI39, BI40, BI41, BI42, BI43, V1, V2, V3, V4, V5, V6, V7, V8, V9, V10, V11, V12, V13, V14)</p>	<p>----- ----- -----</p>	
<p>79 Block Reclose C <i>As Above</i></p>	<p>Combination of (BI1, BI2, BI3, BI4, BI5, BI6, BI7, BI8, BI9, BI10, BI11, BI12, BI13, BI14, BI15, BI16, BI17, BI18, BI19, BI20, BI21, BI22, BI23, BI24, BI25, BI26, BI27, BI28, BI29, BI30, BI31, BI32, BI33, BI34, BI35, BI36, BI37, BI38, BI39, BI40, BI41, BI42, BI43, V1, V2, V3, V4, V5, V6, V7, V8, V9, V10, V11, V12, V13, V14)</p>	<p>----- ----- -----</p>	
<p>79 Reset Lockout A <i>Selects which inputs will force the Auto-recloser into the Lockout state</i></p>	<p>Combination of (BI1, BI2, BI3, BI4, BI5, BI6, BI7, BI8, BI9, BI10, BI11, BI12, BI13, BI14, BI15, BI16, BI17, BI18, BI19, BI20, BI21, BI22, BI23, BI24, BI25, BI26, BI27, BI28, BI29, BI30, BI31, BI32, BI33, BI34, BI35, BI36, BI37, BI38, BI39, BI40, BI41, BI42, BI43, V1, V2, V3, V4, V5, V6, V7, V8, V9, V10, V11, V12, V13, V14)</p>	<p>----- ----- -----</p>	

Description	Range	Default	Setting
79 Reset Lockout B <i>As Above</i>	Combination of (BI1, BI2, BI3, BI4, BI5, BI6, BI7, BI8, BI9, BI10, BI11, BI12, BI13, BI14, BI15, BI16, BI17, BI18, BI19, BI20, BI21, BI22, BI23, BI24, BI25, BI26, BI27, BI28, BI29, BI30, BI31, BI32, BI33, BI34, BI35, BI36, BI37, BI38, BI39, BI40, BI41, BI42, BI43, V1, V2, V3, V4, V5, V6, V7, V8, V9, V10, V11, V12, V13, V14)	----- ----- -----	
79 Reset Lockout C <i>As Above</i>	Combination of (BI1, BI2, BI3, BI4, BI5, BI6, BI7, BI8, BI9, BI10, BI11, BI12, BI13, BI14, BI15, BI16, BI17, BI18, BI19, BI20, BI21, BI22, BI23, BI24, BI25, BI26, BI27, BI28, BI29, BI30, BI31, BI32, BI33, BI34, BI35, BI36, BI37, BI38, BI39, BI40, BI41, BI42, BI43, V1, V2, V3, V4, V5, V6, V7, V8, V9, V10, V11, V12, V13, V14)	----- ----- -----	
79 Line Check A <i>Selects which inputs will start the Line Check functionality of the Auto-recloser</i>	Combination of (BI1, BI2, BI3, BI4, BI5, BI6, BI7, BI8, BI9, BI10, BI11, BI12, BI13, BI14, BI15, BI16, BI17, BI18, BI19, BI20, BI21, BI22, BI23, BI24, BI25, BI26, BI27, BI28, BI29, BI30, BI31, BI32, BI33, BI34, BI35, BI36, BI37, BI38, BI39, BI40, BI41, BI42, BI43, V1, V2, V3, V4, V5, V6, V7, V8, V9, V10, V11, V12, V13, V14)	----- ----- -----	
79 Line Check B <i>As Above</i>	Combination of (BI1, BI2, BI3, BI4, BI5, BI6, BI7, BI8, BI9, BI10, BI11, BI12, BI13, BI14, BI15, BI16, BI17, BI18, BI19, BI20, BI21, BI22, BI23, BI24, BI25, BI26, BI27, BI28, BI29, BI30, BI31, BI32, BI33, BI34, BI35, BI36, BI37, BI38, BI39, BI40, BI41, BI42, BI43, V1, V2, V3, V4, V5, V6, V7, V8, V9, V10, V11, V12, V13, V14)	----- ----- -----	
79 Line Check C <i>As Above</i>	Combination of (BI1, BI2, BI3, BI4, BI5, BI6, BI7, BI8, BI9, BI10, BI11, BI12, BI13, BI14, BI15, BI16, BI17, BI18, BI19, BI20, BI21, BI22, BI23, BI24, BI25, BI26, BI27, BI28, BI29, BI30, BI31, BI32, BI33, BI34, BI35, BI36, BI37, BI38, BI39, BI40, BI41, BI42, BI43, V1, V2, V3, V4, V5, V6, V7, V8, V9, V10, V11, V12, V13, V14)	----- ----- -----	

Description	Range	Default	Setting
<p>79 Lockout A <i>Selects which inputs will force the Auto-recloser into the Lockout state</i></p>	<p>Combination of (BI1, BI2, BI3, BI4, BI5, BI6, BI7, BI8, BI9, BI10, BI11, BI12, BI13, BI14, BI15, BI16, BI17, BI18, BI19, BI20, BI21, BI22, BI23, BI24, BI25, BI26, BI27, BI28, BI29, BI30, BI31, BI32, BI33, BI34, BI35, BI36, BI37, BI38, BI39, BI40, BI41, BI42, BI43, V1, V2, V3, V4, V5, V6, V7, V8, V9, V10, V11, V12, V13, V14)</p>	<p>----- ----- -----</p>	
<p>79 Lockout B <i>As Above</i></p>	<p>Combination of (BI1, BI2, BI3, BI4, BI5, BI6, BI7, BI8, BI9, BI10, BI11, BI12, BI13, BI14, BI15, BI16, BI17, BI18, BI19, BI20, BI21, BI22, BI23, BI24, BI25, BI26, BI27, BI28, BI29, BI30, BI31, BI32, BI33, BI34, BI35, BI36, BI37, BI38, BI39, BI40, BI41, BI42, BI43, V1, V2, V3, V4, V5, V6, V7, V8, V9, V10, V11, V12, V13, V14)</p>	<p>----- ----- -----</p>	
<p>79 Lockout C <i>As Above</i></p>	<p>Combination of (BI1, BI2, BI3, BI4, BI5, BI6, BI7, BI8, BI9, BI10, BI11, BI12, BI13, BI14, BI15, BI16, BI17, BI18, BI19, BI20, BI21, BI22, BI23, BI24, BI25, BI26, BI27, BI28, BI29, BI30, BI31, BI32, BI33, BI34, BI35, BI36, BI37, BI38, BI39, BI40, BI41, BI42, BI43, V1, V2, V3, V4, V5, V6, V7, V8, V9, V10, V11, V12, V13, V14)</p>	<p>----- ----- -----</p>	
<p>Hot Line Out <i>Selects which inputs will switch out Hot Line Working</i></p>	<p>Combination of (BI1, BI2, BI3, BI4, BI5, BI6, BI7, BI8, BI9, BI10, BI11, BI12, BI13, BI14, BI15, BI16, BI17, BI18, BI19, BI20, BI21, BI22, BI23, BI24, BI25, BI26, BI27, BI28, BI29, BI30, BI31, BI32, BI33, BI34, BI35, BI36, BI37, BI38, BI39, BI40, BI41, BI42, BI43, V1, V2, V3, V4, V5, V6, V7, V8, V9, V10, V11, V12, V13, V14)</p>	<p>----- ----- -----</p>	
<p>Hot Line In <i>Selects which inputs will switch in Hot Line Working</i></p>	<p>Combination of (BI1, BI2, BI3, BI4, BI5, BI6, BI7, BI8, BI9, BI10, BI11, BI12, BI13, BI14, BI15, BI16, BI17, BI18, BI19, BI20, BI21, BI22, BI23, BI24, BI25, BI26, BI27, BI28, BI29, BI30, BI31, BI32, BI33, BI34, BI35, BI36, BI37, BI38, BI39, BI40, BI41, BI42, BI43, V1, V2, V3, V4, V5, V6, V7, V8, V9, V10, V11, V12, V13, V14)</p>	<p>----- ----- -----</p>	

Description	Range	Default	Setting
Inst Prot'n Out <i>Selects which inputs will switch out the instantaneous protection elements</i>	Combination of (BI1, BI2, BI3, BI4, BI5, BI6, BI7, BI8, BI9, BI10, BI11, BI12, BI13, BI14, BI15, BI16, BI17, BI18, BI19, BI20, BI21, BI22, BI23, BI24, BI25, BI26, BI27, BI28, BI29, BI30, BI31, BI32, BI33, BI34, BI35, BI36, BI37, BI38, BI39, BI40, BI41, BI42, BI43, V1, V2, V3, V4, V5, V6, V7, V8, V9, V10, V11, V12, V13, V14)	----- ----- -----	
Inst Prot'n In <i>Selects which inputs will switch in the instantaneous protection elements</i>	Combination of (BI1, BI2, BI3, BI4, BI5, BI6, BI7, BI8, BI9, BI10, BI11, BI12, BI13, BI14, BI15, BI16, BI17, BI18, BI19, BI20, BI21, BI22, BI23, BI24, BI25, BI26, BI27, BI28, BI29, BI30, BI31, BI32, BI33, BI34, BI35, BI36, BI37, BI38, BI39, BI40, BI41, BI42, BI43, V1, V2, V3, V4, V5, V6, V7, V8, V9, V10, V11, V12, V13, V14)	----- ----- -----	
E/F Out <i>Selects which inputs will switch out the E/F protection elements.</i>	Combination of (BI1, BI2, BI3, BI4, BI5, BI6, BI7, BI8, BI9, BI10, BI11, BI12, BI13, BI14, BI15, BI16, BI17, BI18, BI19, BI20, BI21, BI22, BI23, BI24, BI25, BI26, BI27, BI28, BI29, BI30, BI31, BI32, BI33, BI34, BI35, BI36, BI37, BI38, BI39, BI40, BI41, BI42, BI43, V1, V2, V3, V4, V5, V6, V7, V8, V9, V10, V11, V12, V13, V14)	----- ----- -----	
E/F In <i>Selects which inputs will switch in the E/F protection elements.</i>	Combination of (BI1, BI2, BI3, BI4, BI5, BI6, BI7, BI8, BI9, BI10, BI11, BI12, BI13, BI14, BI15, BI16, BI17, BI18, BI19, BI20, BI21, BI22, BI23, BI24, BI25, BI26, BI27, BI28, BI29, BI30, BI31, BI32, BI33, BI34, BI35, BI36, BI37, BI38, BI39, BI40, BI41, BI42, BI43, V1, V2, V3, V4, V5, V6, V7, V8, V9, V10, V11, V12, V13, V14)	----- ----- -----	
SEF Out <i>Selects which inputs will switch out the SEF protection elements</i>	Combination of (BI1, BI2, BI3, BI4, BI5, BI6, BI7, BI8, BI9, BI10, BI11, BI12, BI13, BI14, BI15, BI16, BI17, BI18, BI19, BI20, BI21, BI22, BI23, BI24, BI25, BI26, BI27, BI28, BI29, BI30, BI31, BI32, BI33, BI34, BI35, BI36, BI37, BI38, BI39, BI40, BI41, BI42, BI43, V1, V2, V3, V4, V5, V6, V7, V8, V9, V10, V11, V12, V13, V14)	----- ----- -----	

Description	Range	Default	Setting
SEF In <i>Selects which inputs will switch in the SEF protection elements</i>	Combination of (BI1, BI2, BI3, BI4, BI5, BI6, BI7, BI8, BI9, BI10, BI11, BI12, BI13, BI14, BI15, BI16, BI17, BI18, BI19, BI20, BI21, BI22, BI23, BI24, BI25, BI26, BI27, BI28, BI29, BI30, BI31, BI32, BI33, BI34, BI35, BI36, BI37, BI38, BI39, BI40, BI41, BI42, BI43, V1, V2, V3, V4, V5, V6, V7, V8, V9, V10, V11, V12, V13, V14)	----- ----- -----	
Trigger Wave Rec <i>Selects which inputs can trigger a waveform record</i>	Combination of (BI1, BI2, BI3, BI4, BI5, BI6, BI7, BI8, BI9, BI10, BI11, BI12, BI13, BI14, BI15, BI16, BI17, BI18, BI19, BI20, BI21, BI22, BI23, BI24, BI25, BI26, BI27, BI28, BI29, BI30, BI31, BI32, BI33, BI34, BI35, BI36, BI37, BI38, BI39, BI40, BI41, BI42, BI43, V1, V2, V3, V4, V5, V6, V7, V8, V9, V10, V11, V12, V13, V14)	----- ----- -----	
Trigger Fault Rec <i>Selects which inputs can trigger a fault record</i>	Combination of (BI1, BI2, BI3, BI4, BI5, BI6, BI7, BI8, BI9, BI10, BI11, BI12, BI13, BI14, BI15, BI16, BI17, BI18, BI19, BI20, BI21, BI22, BI23, BI24, BI25, BI26, BI27, BI28, BI29, BI30, BI31, BI32, BI33, BI34, BI35, BI36, BI37, BI38, BI39, BI40, BI41, BI42, BI43, V1, V2, V3, V4, V5, V6, V7, V8, V9, V10, V11, V12, V13, V14)	----- ----- -----	
Select Group 1 <i>Switches active setting group to group 1</i>	Combination of (BI1, BI2, BI3, BI4, BI5, BI6, BI7, BI8, BI9, BI10, BI11, BI12, BI13, BI14, BI15, BI16, BI17, BI18, BI19, BI20, BI21, BI22, BI23, BI24, BI25, BI26, BI27, BI28, BI29, BI30, BI31, BI32, BI33, BI34, BI35, BI36, BI37, BI38, BI39, BI40, BI41, BI42, BI43, V1, V2, V3, V4, V5, V6, V7, V8, V9, V10, V11, V12, V13, V14)	----- ----- -----	
Reset Energy Meters	Combination of (BI1, BI2, BI3, BI4, BI5, BI6, BI7, BI8, BI9, BI10, BI11, BI12, BI13, BI14, BI15, BI16, BI17, BI18, BI19, BI20, BI21, BI22, BI23, BI24, BI25, BI26, BI27, BI28, BI29, BI30, BI31, BI32, BI33, BI34, BI35, BI36, BI37, BI38, BI39, BI40, BI41, BI42, BI43, V1, V2, V3, V4, V5, V6, V7, V8, V9, V10, V11, V12, V13, V14)	----- ----- -----	

Description	Range	Default	Setting
Select Group 2 <i>Switches active setting group to group 2</i>	Combination of (BI1, BI2, BI3, BI4, BI5, BI6, BI7, BI8, BI9, BI10, BI11, BI12, BI13, BI14, BI15, BI16, BI17, BI18, BI19, BI20, BI21, BI22, BI23, BI24, BI25, BI26, BI27, BI28, BI29, BI30, BI31, BI32, BI33, BI34, BI35, BI36, BI37, BI38, BI39, BI40, BI41, BI42, BI43, V1, V2, V3, V4, V5, V6, V7, V8, V9, V10, V11, V12, V13, V14)	----- ----- -----	
Select Group 3 <i>Switches active setting group to group 3</i>	Combination of (BI1, BI2, BI3, BI4, BI5, BI6, BI7, BI8, BI9, BI10, BI11, BI12, BI13, BI14, BI15, BI16, BI17, BI18, BI19, BI20, BI21, BI22, BI23, BI24, BI25, BI26, BI27, BI28, BI29, BI30, BI31, BI32, BI33, BI34, BI35, BI36, BI37, BI38, BI39, BI40, BI41, BI42, BI43, V1, V2, V3, V4, V5, V6, V7, V8, V9, V10, V11, V12, V13, V14)	----- ----- -----	
Select Group 4 <i>Switches active setting group to group 4</i>	Combination of (BI1, BI2, BI3, BI4, BI5, BI6, BI7, BI8, BI9, BI10, BI11, BI12, BI13, BI14, BI15, BI16, BI17, BI18, BI19, BI20, BI21, BI22, BI23, BI24, BI25, BI26, BI27, BI28, BI29, BI30, BI31, BI32, BI33, BI34, BI35, BI36, BI37, BI38, BI39, BI40, BI41, BI42, BI43, V1, V2, V3, V4, V5, V6, V7, V8, V9, V10, V11, V12, V13, V14)	----- ----- -----	
Select Group 5 <i>Switches active setting group to group 5</i>	Combination of (BI1, BI2, BI3, BI4, BI5, BI6, BI7, BI8, BI9, BI10, BI11, BI12, BI13, BI14, BI15, BI16, BI17, BI18, BI19, BI20, BI21, BI22, BI23, BI24, BI25, BI26, BI27, BI28, BI29, BI30, BI31, BI32, BI33, BI34, BI35, BI36, BI37, BI38, BI39, BI40, BI41, BI42, BI43, V1, V2, V3, V4, V5, V6, V7, V8, V9, V10, V11, V12, V13, V14)	----- ----- -----	
Select Group 6 <i>Switches active setting group to group 6</i>	Combination of (BI1, BI2, BI3, BI4, BI5, BI6, BI7, BI8, BI9, BI10, BI11, BI12, BI13, BI14, BI15, BI16, BI17, BI18, BI19, BI20, BI21, BI22, BI23, BI24, BI25, BI26, BI27, BI28, BI29, BI30, BI31, BI32, BI33, BI34, BI35, BI36, BI37, BI38, BI39, BI40, BI41, BI42, BI43, V1, V2, V3, V4, V5, V6, V7, V8, V9, V10, V11, V12, V13, V14)	----- ----- -----	

Description	Range	Default	Setting
Select Group 7 <i>Switches active setting group to group 7</i>	Combination of (BI1, BI2, BI3, BI4, BI5, BI6, BI7, BI8, BI9, BI10, BI11, BI12, BI13, BI14, BI15, BI16, BI17, BI18, BI19, BI20, BI21, BI22, BI23, BI24, BI25, BI26, BI27, BI28, BI29, BI30, BI31, BI32, BI33, BI34, BI35, BI36, BI37, BI38, BI39, BI40, BI41, BI42, BI43, V1, V2, V3, V4, V5, V6, V7, V8, V9, V10, V11, V12, V13, V14)	----- ----- -----	
Select Group 8 <i>Switches active setting group to group 8</i>	Combination of (BI1, BI2, BI3, BI4, BI5, BI6, BI7, BI8, BI9, BI10, BI11, BI12, BI13, BI14, BI15, BI16, BI17, BI18, BI19, BI20, BI21, BI22, BI23, BI24, BI25, BI26, BI27, BI28, BI29, BI30, BI31, BI32, BI33, BI34, BI35, BI36, BI37, BI38, BI39, BI40, BI41, BI42, BI43, V1, V2, V3, V4, V5, V6, V7, V8, V9, V10, V11, V12, V13, V14)	----- ----- -----	
Out Of Service Mode <i>Selects which inputs will put the relay into Out Of Service Mode</i>	Combination of (BI1, BI2, BI3, BI4, BI5, BI6, BI7, BI8, BI9, BI10, BI11, BI12, BI13, BI14, BI15, BI16, BI17, BI18, BI19, BI20, BI21, BI22, BI23, BI24, BI25, BI26, BI27, BI28, BI29, BI30, BI31, BI32, BI33, BI34, BI35, BI36, BI37, BI38, BI39, BI40, BI41, BI42, BI43, V1, V2, V3, V4, V5, V6, V7, V8, V9, V10, V11, V12, V13, V14)	----- ----- -----	
Local Mode <i>Selects which inputs will put the relay into Local Mode</i>	Combination of (BI1, BI2, BI3, BI4, BI5, BI6, BI7, BI8, BI9, BI10, BI11, BI12, BI13, BI14, BI15, BI16, BI17, BI18, BI19, BI20, BI21, BI22, BI23, BI24, BI25, BI26, BI27, BI28, BI29, BI30, BI31, BI32, BI33, BI34, BI35, BI36, BI37, BI38, BI39, BI40, BI41, BI42, BI43, V1, V2, V3, V4, V5, V6, V7, V8, V9, V10, V11, V12, V13, V14)	----- ----- -----	
Remote Mode <i>Selects which inputs will put the relay into Remote Mode</i>	Combination of (BI1, BI2, BI3, BI4, BI5, BI6, BI7, BI8, BI9, BI10, BI11, BI12, BI13, BI14, BI15, BI16, BI17, BI18, BI19, BI20, BI21, BI22, BI23, BI24, BI25, BI26, BI27, BI28, BI29, BI30, BI31, BI32, BI33, BI34, BI35, BI36, BI37, BI38, BI39, BI40, BI41, BI42, BI43, V1, V2, V3, V4, V5, V6, V7, V8, V9, V10, V11, V12, V13, V14)	----- ----- -----	

Description	Range	Default	Setting
Local Or Remote Mode <i>Selects which inputs will put the relay into Local Or Remote Mode</i>	Combination of (BI1, BI2, BI3, BI4, BI5, BI6, BI7, BI8, BI9, BI10, BI11, BI12, BI13, BI14, BI15, BI16, BI17, BI18, BI19, BI20, BI21, BI22, BI23, BI24, BI25, BI26, BI27, BI28, BI29, BI30, BI31, BI32, BI33, BI34, BI35, BI36, BI37, BI38, BI39, BI40, BI41, BI42, BI43, V1, V2, V3, V4, V5, V6, V7, V8, V9, V10, V11, V12, V13, V14)	----- ----- -----	
Clock Sync. <i>Selects which input is used to synchronise the real time clock</i>	Combination of (BI1, BI2, BI3, BI4, BI5, BI6, BI7, BI8, BI9, BI10, BI11, BI12, BI13, BI14, BI15, BI16, BI17, BI18, BI19, BI20, BI21, BI22, BI23, BI24, BI25, BI26, BI27, BI28, BI29, BI30, BI31, BI32, BI33, BI34, BI35, BI36, BI37, BI38, BI39, BI40, BI41, BI42, BI43, V1, V2, V3, V4, V5, V6, V7, V8, V9, V10, V11, V12, V13, V14)	----- ----- -----	
Reset LEDs & O/Ps <i>Selects which inputs will reset the latched LEDs and binary outputs</i>	Combination of (BI1, BI2, BI3, BI4, BI5, BI6, BI7, BI8, BI9, BI10, BI11, BI12, BI13, BI14, BI15, BI16, BI17, BI18, BI19, BI20, BI21, BI22, BI23, BI24, BI25, BI26, BI27, BI28, BI29, BI30, BI31, BI32, BI33, BI34, BI35, BI36, BI37, BI38, BI39, BI40, BI41, BI42, BI43, V1, V2, V3, V4, V5, V6, V7, V8, V9, V10, V11, V12, V13, V14)	----- ----- -----	

5.8.2. Function Key Matrix

Description	Range	Default	Setting
Open CB-A <i>Selects which function key will Open the circuit breaker</i>	Combination of (1, 2, 3, 4, 5, 6, 7, 8, 9, 10, 11, 12)	-----	
Close CB-A <i>Selects which function key will Close the circuit breaker</i>	Combination of (1, 2, 3, 4, 5, 6, 7, 8, 9, 10, 11, 12)	-----	
Open CB-B <i>Selects which function key will Open the circuit breaker</i>	Combination of (1, 2, 3, 4, 5, 6, 7, 8, 9, 10, 11, 12)	-----	
Close CB-B <i>Selects which function key will Close the circuit breaker</i>	Combination of (1, 2, 3, 4, 5, 6, 7, 8, 9, 10, 11, 12)	-----	
Open CB-C <i>Selects which function key will Open the circuit breaker</i>	Combination of (1, 2, 3, 4, 5, 6, 7, 8, 9, 10, 11, 12)	-----	
Close CB-C <i>Selects which function key will Close the circuit breaker</i>	Combination of (1, 2, 3, 4, 5, 6, 7, 8, 9, 10, 11, 12)	-----	
79 In/Out <i>Selects which function key will toggle Autoreclose In & Out</i>	Combination of (1, 2, 3, 4, 5, 6, 7, 8, 9, 10, 11, 12)	-----	

Description	Range	Default	Setting
Mode A - 3PTrip3PLO <i>Selects which function key will Set the relay to operate in Mode A (3 pole Trip & 3 pole lockout)</i>	Combination of (1, 2, 3, 4, 5, 6, 7, 8, 9, 10, 11, 12)	-----	
Mode B - 1PTrip3PLO <i>Selects which function key will Set the relay to operate in Mode B (1 pole Trip & 3 pole lockout)</i>	Combination of (1, 2, 3, 4, 5, 6, 7, 8, 9, 10, 11, 12)	-----	
Mode C - 1PTrip1PLO <i>Selects which function key will Set the relay to operate in Mode C (1 pole Trip & 1 pole lockout)</i>	Combination of (1, 2, 3, 4, 5, 6, 7, 8, 9, 10, 11, 12)	-----	
79 Trip & Reclose 3Ph <i>Selects which function key will cause the CB to trip & reclose</i>	Combination of (1, 2, 3, 4, 5, 6, 7, 8, 9, 10, 11, 12)	-----	
79 Trip & Lockout A <i>Selects which function key will cause the CB to trip & lockout</i>	Combination of (1, 2, 3, 4, 5, 6, 7, 8, 9, 10, 11, 12)	-----	
79 Trip & Lockout B <i>As Above</i>	Combination of (1, 2, 3, 4, 5, 6, 7, 8, 9, 10, 11, 12)	-----	
79 Trip & Lockout C <i>As Above</i>	Combination of (1, 2, 3, 4, 5, 6, 7, 8, 9, 10, 11, 12)	-----	
Hot Line Work In/Out <i>Selects which function key will toggle Hot Line Working In & Out</i>	Combination of (1, 2, 3, 4, 5, 6, 7, 8, 9, 10, 11, 12)	-----	
E/F In/Out <i>Selects which function key will toggle E/F protection In & Out</i>	Combination of (1, 2, 3, 4, 5, 6, 7, 8, 9, 10, 11, 12)	-----	
SEF In/Out <i>Selects which function key will toggle SEF protection In & Out</i>	Combination of (1, 2, 3, 4, 5, 6, 7, 8, 9, 10, 11, 12)	-----	
Inst Prot'n In/Out <i>Selects which function key will toggle Instantaneous protection elements In & Out</i>	Combination of (1, 2, 3, 4, 5, 6, 7, 8, 9, 10, 11, 12)	-----	
Out Of Service Mode	Combination of (1, 2, 3, 4, 5, 6, 7, 8, 9, 10, 11, 12)	-----	
Local Mode	Combination of (1, 2, 3, 4, 5, 6, 7, 8, 9, 10, 11, 12)	-----	
Remote Mode	Combination of (1, 2, 3, 4, 5, 6, 7, 8, 9, 10, 11, 12)	-----	
Local Or Remote Mode <i>Selects which inputs will put the relay into Local Or Remote Mode</i>	Combination of (1, 2, 3, 4, 5, 6, 7, 8, 9, 10, 11, 12)	-----	
BatteryTestRequired <i>Selects which inputs will initiate a Battery test</i>	Combination of (1, 2, 3, 4, 5, 6, 7, 8, 9, 10, 11, 12)	-----	

5.8.3. Binary Input Config

Description	Range	Default	Setting
Inverted Inputs <i>Selects which inputs pickup when voltage is removed.</i>	Combination of (1, 2, 3, 4, 5, 6, 7, 8, 9, 10, 11, 12, 13, 14, 15, 16, 17, 18, 19, 20, 21, 22, 23, 24, 25, 26, 27, 28, 29, 30, 31, 32, 33, 34, 35, 36, 37, 38, 39, 40, 41, 42, 43)	----- ----- ----	
BI 1 Pickup Delay <i>Delay on pickup of DC Binary Input 1</i>	0, 0.005 ... 14300, 14400	0.02s	
BI 1 Dropoff Delay <i>Delay on dropoff of DC Binary Input 1</i>	0, 0.005 ... 14300, 14400	0s	
BI 2 Pickup Delay <i>Delay on pickup of DC Binary Input 2</i>	0, 0.005 ... 14300, 14400	0.02s	
BI 2 Dropoff Delay <i>Delay on dropoff of DC Binary Input 2</i>	0, 0.005 ... 14300, 14400	0s	
BI 3 Pickup Delay <i>Delay on pickup of DC Binary Input 3</i>	0, 0.005 ... 14300, 14400	0.02s	
BI 3 Dropoff Delay <i>Delay on dropoff of DC Binary Input 3</i>	0, 0.005 ... 14300, 14400	0s	
BI 4 Pickup Delay <i>Delay on pickup of DC Binary Input 4</i>	0, 0.005 ... 14300, 14400	0.02s	
BI 4 Dropoff Delay <i>Delay on dropoff of DC Binary Input 4</i>	0, 0.005 ... 14300, 14400	0s	
BI 5 Pickup Delay <i>Delay on pickup of DC Binary Input 5</i>	0, 0.005 ... 14300, 14400	0.02s	
BI 5 Dropoff Delay <i>Delay on dropoff of DC Binary Input 5</i>	0, 0.005 ... 14300, 14400	0s	
BI 6 Pickup Delay <i>Delay on pickup of DC Binary Input 6</i>	0, 0.005 ... 14300, 14400	0.02s	
BI 6 Dropoff Delay <i>Delay on dropoff of DC Binary Input 6</i>	0, 0.005 ... 14300, 14400	0s	
BI 7 Pickup Delay <i>Delay on pickup of DC Binary Input 7</i>	0, 0.005 ... 14300, 14400	0.02s	
BI 7 Dropoff Delay <i>Delay on dropoff of DC Binary Input 7</i>	0, 0.005 ... 14300, 14400	0s	
BI 8 Pickup Delay <i>Delay on pickup of DC Binary Input 8</i>	0, 0.005 ... 14300, 14400	0.02s	
BI 8 Dropoff Delay <i>Delay on dropoff of DC Binary Input 8</i>	0, 0.005 ... 14300, 14400	0s	
BI 9 Pickup Delay <i>Delay on pickup of DC Binary Input 9</i>	0, 0.005 ... 14300, 14400	0.02s	
BI 9 Dropoff Delay <i>Delay on dropoff of DC Binary Input 9</i>	0, 0.005 ... 14300, 14400	0s	
BI 10 Pickup Delay <i>Delay on pickup of DC Binary Input 10</i>	0, 0.005 ... 14300, 14400	0.02s	
BI 10 Dropoff Delay <i>Delay on dropoff of DC Binary Input 10</i>	0, 0.005 ... 14300, 14400	0s	

Description	Range	Default	Setting
BI 11 Pickup Delay <i>Delay on pickup of DC Binary Input 11</i>	0, 0.005 ... 14300, 14400	0.02s	
BI 11 Dropoff Delay <i>Delay on dropoff of DC Binary Input 11</i>	0, 0.005 ... 14300, 14400	0s	
BI 12 Pickup Delay <i>Delay on pickup of DC Binary Input 12</i>	0, 0.005 ... 14300, 14400	0.02s	
BI 12 Dropoff Delay <i>Delay on dropoff of DC Binary Input 12</i>	0, 0.005 ... 14300, 14400	0s	
BI 13 Pickup Delay <i>Delay on pickup of DC Binary Input 13</i>	0, 0.005 ... 14300, 14400	0.02s	
BI 13 Dropoff Delay <i>Delay on dropoff of DC Binary Input 13</i>	0, 0.005 ... 14300, 14400	0s	
BI 14 Pickup Delay <i>Delay on pickup of DC Binary Input 14</i>	0, 0.005 ... 14300, 14400	0.02s	
BI 14 Dropoff Delay <i>Delay on dropoff of DC Binary Input 14</i>	0, 0.005 ... 14300, 14400	0s	
BI 15 Pickup Delay <i>Delay on pickup of DC Binary Input 15</i>	0, 0.005 ... 14300, 14400	0.02s	
BI 15 Dropoff Delay <i>Delay on dropoff of DC Binary Input 15</i>	0, 0.005 ... 14300, 14400	0s	
BI 16 Pickup Delay <i>Delay on pickup of DC Binary Input 16</i>	0, 0.005 ... 14300, 14400	0.02s	
BI 16 Dropoff Delay <i>Delay on dropoff of DC Binary Input 16</i>	0, 0.005 ... 14300, 14400	0s	
BI 17 Pickup Delay <i>Delay on pickup of DC Binary Input 17</i>	0, 0.005 ... 14300, 14400	0.02s	
BI 17 Dropoff Delay <i>Delay on dropoff of DC Binary Input 17</i>	0, 0.005 ... 14300, 14400	0s	
BI 18 Pickup Delay <i>Delay on pickup of DC Binary Input 18</i>	0, 0.005 ... 14300, 14400	0.02s	
BI 18 Dropoff Delay <i>Delay on dropoff of DC Binary Input 18</i>	0, 0.005 ... 14300, 14400	0s	
BI 19 Pickup Delay <i>Delay on pickup of DC Binary Input 19</i>	0, 0.005 ... 14300, 14400	0.02s	
BI 19 Dropoff Delay <i>Delay on dropoff of DC Binary Input 19</i>	0, 0.005 ... 14300, 14400	0s	
BI 20 Pickup Delay <i>Delay on pickup of DC Binary Input 20</i>	0, 0.005 ... 14300, 14400	0.02s	
BI 20 Dropoff Delay <i>Delay on dropoff of DC Binary Input 20</i>	0, 0.005 ... 14300, 14400	0s	
BI 21 Pickup Delay <i>Delay on pickup of DC Binary Input 21</i>	0, 0.005 ... 14300, 14400	0.02s	
BI 21 Dropoff Delay <i>Delay on dropoff of DC Binary Input 21</i>	0, 0.005 ... 14300, 14400	0s	
BI 22 Pickup Delay <i>Delay on pickup of DC Binary Input 22</i>	0, 0.005 ... 14300, 14400	0.02s	
BI 22 Dropoff Delay <i>Delay on dropoff of DC Binary Input 22</i>	0, 0.005 ... 14300, 14400	0s	

Description	Range	Default	Setting
BI 23 Pickup Delay <i>Delay on pickup of DC Binary Input 23</i>	0, 0.005 ... 14300, 14400	0.02s	
BI 23 Dropoff Delay <i>Delay on dropoff of DC Binary Input 23</i>	0, 0.005 ... 14300, 14400	0s	
BI 24 Pickup Delay <i>Delay on pickup of DC Binary Input 24</i>	0, 0.005 ... 14300, 14400	0.02s	
BI 24 Dropoff Delay <i>Delay on dropoff of DC Binary Input 24</i>	0, 0.005 ... 14300, 14400	0s	
BI 25 Pickup Delay <i>Delay on pickup of DC Binary Input 25</i>	0, 0.005 ... 14300, 14400	0.02s	
BI 25 Dropoff Delay <i>Delay on dropoff of DC Binary Input 25</i>	0, 0.005 ... 14300, 14400	0s	
BI 26 Pickup Delay <i>Delay on pickup of DC Binary Input 26</i>	0, 0.005 ... 14300, 14400	0.02s	
BI 26 Dropoff Delay <i>Delay on dropoff of DC Binary Input 26</i>	0, 0.005 ... 14300, 14400	0s	
BI 27 Pickup Delay <i>Delay on pickup of DC Binary Input 27</i>	0, 0.005 ... 14300, 14400	0.02s	
BI 27 Dropoff Delay <i>Delay on dropoff of DC Binary Input 27</i>	0, 0.005 ... 14300, 14400	0s	
BI 28 Pickup Delay <i>Delay on pickup of DC Binary Input 28</i>	0, 0.005 ... 14300, 14400	0.02s	
BI 28 Dropoff Delay <i>Delay on dropoff of DC Binary Input 28</i>	0, 0.005 ... 14300, 14400	0s	
BI 29 Pickup Delay <i>Delay on pickup of DC Binary Input 29</i>	0, 0.005 ... 14300, 14400	0.02s	
BI 29 Dropoff Delay <i>Delay on dropoff of DC Binary Input 29</i>	0, 0.005 ... 14300, 14400	0s	
BI 30 Pickup Delay <i>Delay on pickup of DC Binary Input 30</i>	0, 0.005 ... 14300, 14400	0.02s	
BI 30 Dropoff Delay <i>Delay on dropoff of DC Binary Input 30</i>	0, 0.005 ... 14300, 14400	0s	
BI 31 Pickup Delay <i>Delay on pickup of DC Binary Input 31</i>	0, 0.005 ... 14300, 14400	0.02s	
BI 31 Dropoff Delay <i>Delay on dropoff of DC Binary Input 31</i>	0, 0.005 ... 14300, 14400	0s	
BI 32 Pickup Delay <i>Delay on pickup of DC Binary Input 32</i>	0, 0.005 ... 14300, 14400	0.02s	
BI 32 Dropoff Delay <i>Delay on dropoff of DC Binary Input 32</i>	0, 0.005 ... 14300, 14400	0s	
BI 33 Pickup Delay <i>Delay on pickup of DC Binary Input 33</i>	0, 0.005 ... 14300, 14400	0.02s	
BI 33 Dropoff Delay <i>Delay on dropoff of DC Binary Input 33</i>	0, 0.005 ... 14300, 14400	0s	
BI 34 Pickup Delay	0, 0.005 ... 14300, 14400	0.02s	
BI 34 Dropoff Delay	0, 0.005 ... 14300, 14400	0s	

Description	Range	Default	Setting
BI 35 Pickup Delay	0, 0.005 ... 14300, 14400	0.02s	
BI 35 Dropoff Delay	0, 0.005 ... 14300, 14400	0s	
BI 36 Pickup Delay	0, 0.005 ... 14300, 14400	0.02s	
BI 36 Dropoff Delay	0, 0.005 ... 14300, 14400	0s	
BI 37 Pickup Delay	0, 0.005 ... 14300, 14400	0.02s	
BI 37 Dropoff Delay	0, 0.005 ... 14300, 14400	0s	
BI 38 Pickup Delay	0, 0.005 ... 14300, 14400	0.02s	
BI 38 Dropoff Delay	0, 0.005 ... 14300, 14400	0s	
BI 39 Pickup Delay	0, 0.005 ... 14300, 14400	0.02s	
BI 39 Dropoff Delay	0, 0.005 ... 14300, 14400	0s	
BI 40 Pickup Delay	0, 0.005 ... 14300, 14400	0.02s	
BI 40 Dropoff Delay	0, 0.005 ... 14300, 14400	0s	
BI 41 Pickup Delay	0, 0.005 ... 14300, 14400	0.02s	
BI 41 Dropoff Delay	0, 0.005 ... 14300, 14400	0s	
BI 42 Pickup Delay	0, 0.005 ... 14300, 14400	0.02s	
BI 42 Dropoff Delay	0, 0.005 ... 14300, 14400	0s	
BI 43 Pickup Delay	0, 0.005 ... 14300, 14400	0.02s	
BI 43 Dropoff Delay	0, 0.005 ... 14300, 14400	0s	
Enabled In Local <i>Selects which inputs are enabled when the relay is in Operating Mode 'Local' or 'Local Or Remote'</i>	Combination of (1, 2, 3, 4, 5, 6, 7, 8, 9, 10, 11, 12, 13, 14, 15, 16, 17, 18, 19, 20, 21, 22, 23, 24, 25, 26, 27, 28, 29, 30, 31, 32, 33, 34, 35, 36, 37, 38, 39, 40, 41, 42, 43)	1, 2, 3, 4, 5, 6, 7, 8, 9, 10, 11, 12, 13, 14, 15, 16, 17, 18, 19, 20, 21, 22, 23, 24, 25, 26, 27, 28, 29, 30, 31, 32, 33, 34, 35, 36, 37, 38, 39, 40, 41, 42, 43	

Description	Range	Default	Setting
<p>Enabled In Remote</p> <p>Selects which inputs are enabled when the relay is in Operating Mode 'Remote' or 'Local Or Remote'</p>	Combination of (1, 2, 3, 4, 5, 6, 7, 8, 9, 10, 11, 12, 13, 14, 15, 16, 17, 18, 19, 20, 21, 22, 23, 24, 25, 26, 27, 28, 29, 30, 31, 32, 33, 34, 35, 36, 37, 38, 39, 40, 41, 42, 43)	1, 2, 3, 4, 5, 6, 7, 8, 9, 10, 11, 12, 13, 14, 15, 16, 17, 18, 19, 20, 21, 22, 23, 24, 25, 26, 27, 28, 29, 30, 31, 32, 33, 34, 35, 36, 37, 38, 39, 40, 41, 42, 43	

5.8.4. Function Key Config

Description	Range	Default	Setting
<p>Function Key 1 Text</p> <p>User definable text that will be used in the HMI function key confirmation screen when Function key 1 is pressed.</p>	(20 Character String)	Function Key 1	
<p>Function Key 2 Text</p> <p>User definable text that will be used in the HMI function key confirmation screen when Function key 2 is pressed.</p>	(20 Character String)	Function Key 2	
<p>Function Key 3 Text</p> <p>User definable text that will be used in the HMI function key confirmation screen when Function key 3 is pressed.</p>	(20 Character String)	Function Key 3	
<p>Function Key 4 Text</p> <p>User definable text that will be used in the HMI function key confirmation screen when Function key 4 is pressed.</p>	(20 Character String)	Function Key 4	
<p>Function Key 5 Text</p> <p>User definable text that will be used in the HMI function key confirmation screen when Function key 5 is pressed.</p>	(20 Character String)	Function Key 5	
<p>Function Key 6 Text</p> <p>User definable text that will be used in the HMI function key confirmation screen when Function key 6 is pressed.</p>	(20 Character String)	Function Key 6	
<p>Function Key 7 Text</p> <p>User definable text that will be used in the HMI function key confirmation screen when Function key 7 is pressed.</p>	(20 Character String)	Function Key 7	
<p>Function Key 8 Text</p> <p>User definable text that will be used in the HMI function key confirmation screen when Function key 8 is pressed.</p>	(20 Character String)	Function Key 8	
<p>Function Key 9 Text</p> <p>User definable text that will be used in the HMI function key confirmation screen when Function key 9 is pressed.</p>	(20 Character String)	Function Key 9	
<p>Function Key 10 Text</p> <p>User definable text that will be used in the HMI function key confirmation screen when Function key 10 is pressed.</p>	(20 Character String)	Function Key 10	

Description	Range	Default	Setting
Function Key 11 Text <i>User definable text that will be used in the HMI function key confirmation screen when Function key 11 is pressed.</i>	(20 Character String)	Function Key 11	
Function Key 12 Text <i>User definable text that will be used in the HMI function key confirmation screen when Function key 12 is pressed.</i>	(20 Character String)	Function Key 12	
Enabled In Remote <i>Selects which inputs are enabled when the relay is in Operating Mode 'Remote' or 'Local Or Remote'</i>	Combination of (1, 2, 3, 4, 5, 6, 7, 8, 9, 10, 11, 12)	----- 1668183366	

5.8.5. General Alarms

Description	Range	Default	Setting
General Alarm-1 <i>Defines the text to be displayed for General Alarm 1</i>	(16 Character String)	ALARM 1	
General Alarm-2 <i>Defines the text to be displayed for General Alarm 2</i>	(16 Character String)	ALARM 2	
General Alarm-3 <i>Defines the text to be displayed for General Alarm 3</i>	(16 Character String)	ALARM 3	
General Alarm-4 <i>Defines the text to be displayed for General Alarm 4</i>	(16 Character String)	ALARM 4	
General Alarm-5 <i>Defines the text to be displayed for General Alarm 5</i>	(16 Character String)	ALARM 5	
General Alarm-6 <i>Defines the text to be displayed for General Alarm 6</i>	(16 Character String)	ALARM 6	
General Alarm-7 <i>Defines the text to be displayed for General Alarm 7</i>	(16 Character String)	ALARM 7	
General Alarm-8 <i>Defines the text to be displayed for General Alarm 8</i>	(16 Character String)	ALARM 8	
General Alarm-9 <i>Defines the text to be displayed for General Alarm 9</i>	(16 Character String)	ALARM 9	
General Alarm-10 <i>Defines the text to be displayed for General Alarm 10</i>	(16 Character String)	ALARM 10	
General Alarm-11 <i>Defines the text to be displayed for General Alarm 11</i>	(16 Character String)	ALARM 11	
General Alarm-12 <i>Defines the text to be displayed for General Alarm 12</i>	(16 Character String)	ALARM 12	

5.9. Output Config

5.9.1. Output Matrix

Description	Range	Default	Setting
Protection Healthy <i>Relays selected are energised whilst relay self-monitoring does NOT detect any hardware or software errors and DC Supply is healthy. A changeover contact or normally closed contact may be used to generate Protection Defective from this output</i>	Combination of (BO1, BO2, BO3, BO4, BO5, BO6, BO7, BO8, BO9, BO10, BO11, BO12, BO13, BO14, BO15, BO16, BO17, BO18, BO19, BO20, BO21, BO22, L1, L2, L3, L4, L5, L6, L7, L8, L9, L10, L11, L12, L13, L14, L15, L16, L17, L18, L19, L20, L21, L22, L23, L24, L25, L26, L27, L28, V1, V2, V3, V4, V5, V6, V7, V8, V9, V10, V11, V12, V13, V14)	BO1	
51-1 <i>51-1 IDMTL/DTL Overcurrent operated</i>	Combination of (BO1, BO2, BO3, BO4, BO5, BO6, BO7, BO8, BO9, BO10, BO11, BO12, BO13, BO14, BO15, BO16, BO17, BO18, BO19, BO20, BO21, BO22, L1, L2, L3, L4, L5, L6, L7, L8, L9, L10, L11, L12, L13, L14, L15, L16, L17, L18, L19, L20, L21, L22, L23, L24, L25, L26, L27, L28, V1, V2, V3, V4, V5, V6, V7, V8, V9, V10, V11, V12, V13, V14)	----- ----- ----- -----	
51-2 <i>51-2 IDMTL/DTL Overcurrent operated</i>	Combination of (BO1, BO2, BO3, BO4, BO5, BO6, BO7, BO8, BO9, BO10, BO11, BO12, BO13, BO14, BO15, BO16, BO17, BO18, BO19, BO20, BO21, BO22, L1, L2, L3, L4, L5, L6, L7, L8, L9, L10, L11, L12, L13, L14, L15, L16, L17, L18, L19, L20, L21, L22, L23, L24, L25, L26, L27, L28, V1, V2, V3, V4, V5, V6, V7, V8, V9, V10, V11, V12, V13, V14)	----- ----- ----- -----	
51-3 <i>51-3 IDMTL/DTL Overcurrent operated</i>	Combination of (BO1, BO2, BO3, BO4, BO5, BO6, BO7, BO8, BO9, BO10, BO11, BO12, BO13, BO14, BO15, BO16, BO17, BO18, BO19, BO20, BO21, BO22, L1, L2, L3, L4, L5, L6, L7, L8, L9, L10, L11, L12, L13, L14, L15, L16, L17, L18, L19, L20, L21, L22, L23, L24, L25, L26, L27, L28, V1, V2, V3, V4, V5, V6, V7, V8, V9, V10, V11, V12, V13, V14)	----- ----- ----- -----	

Description	Range	Default	Setting
51-4 <i>51-4 IDMTL/DTL Overcurrent operated</i>	Combination of (BO1, BO2, BO3, BO4, BO5, BO6, BO7, BO8, BO9, BO10, BO11, BO12, BO13, BO14, BO15, BO16, BO17, BO18, BO19, BO20, BO21, BO22, L1, L2, L3, L4, L5, L6, L7, L8, L9, L10, L11, L12, L13, L14, L15, L16, L17, L18, L19, L20, L21, L22, L23, L24, L25, L26, L27, L28, V1, V2, V3, V4, V5, V6, V7, V8, V9, V10, V11, V12, V13, V14)	----- ----- ----- -----	
50-1 <i>50-1 INST/DTL Overcurrent operated</i>	Combination of (BO1, BO2, BO3, BO4, BO5, BO6, BO7, BO8, BO9, BO10, BO11, BO12, BO13, BO14, BO15, BO16, BO17, BO18, BO19, BO20, BO21, BO22, L1, L2, L3, L4, L5, L6, L7, L8, L9, L10, L11, L12, L13, L14, L15, L16, L17, L18, L19, L20, L21, L22, L23, L24, L25, L26, L27, L28, V1, V2, V3, V4, V5, V6, V7, V8, V9, V10, V11, V12, V13, V14)	----- ----- ----- -----	
50-2 <i>50-2 INST/DTL Overcurrent operated</i>	Combination of (BO1, BO2, BO3, BO4, BO5, BO6, BO7, BO8, BO9, BO10, BO11, BO12, BO13, BO14, BO15, BO16, BO17, BO18, BO19, BO20, BO21, BO22, L1, L2, L3, L4, L5, L6, L7, L8, L9, L10, L11, L12, L13, L14, L15, L16, L17, L18, L19, L20, L21, L22, L23, L24, L25, L26, L27, L28, V1, V2, V3, V4, V5, V6, V7, V8, V9, V10, V11, V12, V13, V14)	----- ----- ----- -----	
50-3 <i>50-3 INST/DTL Overcurrent operated</i>	Combination of (BO1, BO2, BO3, BO4, BO5, BO6, BO7, BO8, BO9, BO10, BO11, BO12, BO13, BO14, BO15, BO16, BO17, BO18, BO19, BO20, BO21, BO22, L1, L2, L3, L4, L5, L6, L7, L8, L9, L10, L11, L12, L13, L14, L15, L16, L17, L18, L19, L20, L21, L22, L23, L24, L25, L26, L27, L28, V1, V2, V3, V4, V5, V6, V7, V8, V9, V10, V11, V12, V13, V14)	----- ----- ----- -----	

Description	Range	Default	Setting
50-4 <i>50-4 INST/DTL Overcurrent operated</i>	Combination of (BO1, BO2, BO3, BO4, BO5, BO6, BO7, BO8, BO9, BO10, BO11, BO12, BO13, BO14, BO15, BO16, BO17, BO18, BO19, BO20, BO21, BO22, L1, L2, L3, L4, L5, L6, L7, L8, L9, L10, L11, L12, L13, L14, L15, L16, L17, L18, L19, L20, L21, L22, L23, L24, L25, L26, L27, L28, V1, V2, V3, V4, V5, V6, V7, V8, V9, V10, V11, V12, V13, V14)	----- ----- ----- -----	
51G-1 <i>51G-1 IDMTL/DTL measured Earth Fault operated</i>	Combination of (BO1, BO2, BO3, BO4, BO5, BO6, BO7, BO8, BO9, BO10, BO11, BO12, BO13, BO14, BO15, BO16, BO17, BO18, BO19, BO20, BO21, BO22, L1, L2, L3, L4, L5, L6, L7, L8, L9, L10, L11, L12, L13, L14, L15, L16, L17, L18, L19, L20, L21, L22, L23, L24, L25, L26, L27, L28, V1, V2, V3, V4, V5, V6, V7, V8, V9, V10, V11, V12, V13, V14)	L4	
51G-2 <i>51G-2 IDMTL/DTL measured Earth Fault operated</i>	Combination of (BO1, BO2, BO3, BO4, BO5, BO6, BO7, BO8, BO9, BO10, BO11, BO12, BO13, BO14, BO15, BO16, BO17, BO18, BO19, BO20, BO21, BO22, L1, L2, L3, L4, L5, L6, L7, L8, L9, L10, L11, L12, L13, L14, L15, L16, L17, L18, L19, L20, L21, L22, L23, L24, L25, L26, L27, L28, V1, V2, V3, V4, V5, V6, V7, V8, V9, V10, V11, V12, V13, V14)	L4	
51G-3 <i>51G-3 IDMTL/DTL measured Earth Fault operated</i>	Combination of (BO1, BO2, BO3, BO4, BO5, BO6, BO7, BO8, BO9, BO10, BO11, BO12, BO13, BO14, BO15, BO16, BO17, BO18, BO19, BO20, BO21, BO22, L1, L2, L3, L4, L5, L6, L7, L8, L9, L10, L11, L12, L13, L14, L15, L16, L17, L18, L19, L20, L21, L22, L23, L24, L25, L26, L27, L28, V1, V2, V3, V4, V5, V6, V7, V8, V9, V10, V11, V12, V13, V14)	L4	

Description	Range	Default	Setting
51G-4 <i>51G-4 IDMTL/DTL measured Earth Fault operated</i>	Combination of (BO1, BO2, BO3, BO4, BO5, BO6, BO7, BO8, BO9, BO10, BO11, BO12, BO13, BO14, BO15, BO16, BO17, BO18, BO19, BO20, BO21, BO22, L1, L2, L3, L4, L5, L6, L7, L8, L9, L10, L11, L12, L13, L14, L15, L16, L17, L18, L19, L20, L21, L22, L23, L24, L25, L26, L27, L28, V1, V2, V3, V4, V5, V6, V7, V8, V9, V10, V11, V12, V13, V14)	L4	
50G-1 <i>50G-1 INST/DTL measured Earth Fault operated</i>	Combination of (BO1, BO2, BO3, BO4, BO5, BO6, BO7, BO8, BO9, BO10, BO11, BO12, BO13, BO14, BO15, BO16, BO17, BO18, BO19, BO20, BO21, BO22, L1, L2, L3, L4, L5, L6, L7, L8, L9, L10, L11, L12, L13, L14, L15, L16, L17, L18, L19, L20, L21, L22, L23, L24, L25, L26, L27, L28, V1, V2, V3, V4, V5, V6, V7, V8, V9, V10, V11, V12, V13, V14)	L4	
50G-2 <i>50G-2 INST/DTL measured Earth Fault operated</i>	Combination of (BO1, BO2, BO3, BO4, BO5, BO6, BO7, BO8, BO9, BO10, BO11, BO12, BO13, BO14, BO15, BO16, BO17, BO18, BO19, BO20, BO21, BO22, L1, L2, L3, L4, L5, L6, L7, L8, L9, L10, L11, L12, L13, L14, L15, L16, L17, L18, L19, L20, L21, L22, L23, L24, L25, L26, L27, L28, V1, V2, V3, V4, V5, V6, V7, V8, V9, V10, V11, V12, V13, V14)	L4	
50G-3 <i>50G-3 INST/DTL measured Earth Fault operated</i>	Combination of (BO1, BO2, BO3, BO4, BO5, BO6, BO7, BO8, BO9, BO10, BO11, BO12, BO13, BO14, BO15, BO16, BO17, BO18, BO19, BO20, BO21, BO22, L1, L2, L3, L4, L5, L6, L7, L8, L9, L10, L11, L12, L13, L14, L15, L16, L17, L18, L19, L20, L21, L22, L23, L24, L25, L26, L27, L28, V1, V2, V3, V4, V5, V6, V7, V8, V9, V10, V11, V12, V13, V14)	L4	

Description	Range	Default	Setting
50G-4 <i>50G-4 INST/DTL measured Earth Fault operated</i>	Combination of (BO1, BO2, BO3, BO4, BO5, BO6, BO7, BO8, BO9, BO10, BO11, BO12, BO13, BO14, BO15, BO16, BO17, BO18, BO19, BO20, BO21, BO22, L1, L2, L3, L4, L5, L6, L7, L8, L9, L10, L11, L12, L13, L14, L15, L16, L17, L18, L19, L20, L21, L22, L23, L24, L25, L26, L27, L28, V1, V2, V3, V4, V5, V6, V7, V8, V9, V10, V11, V12, V13, V14)	L4	
51SEF-1 <i>51SEF-1 IDMTL/DTL Sensitive Earth Fault operated</i>	Combination of (BO1, BO2, BO3, BO4, BO5, BO6, BO7, BO8, BO9, BO10, BO11, BO12, BO13, BO14, BO15, BO16, BO17, BO18, BO19, BO20, BO21, BO22, L1, L2, L3, L4, L5, L6, L7, L8, L9, L10, L11, L12, L13, L14, L15, L16, L17, L18, L19, L20, L21, L22, L23, L24, L25, L26, L27, L28, V1, V2, V3, V4, V5, V6, V7, V8, V9, V10, V11, V12, V13, V14)	L5	
51SEF-2 <i>51SEF-2 IDMTL/DTL Sensitive Earth Fault operated</i>	Combination of (BO1, BO2, BO3, BO4, BO5, BO6, BO7, BO8, BO9, BO10, BO11, BO12, BO13, BO14, BO15, BO16, BO17, BO18, BO19, BO20, BO21, BO22, L1, L2, L3, L4, L5, L6, L7, L8, L9, L10, L11, L12, L13, L14, L15, L16, L17, L18, L19, L20, L21, L22, L23, L24, L25, L26, L27, L28, V1, V2, V3, V4, V5, V6, V7, V8, V9, V10, V11, V12, V13, V14)	L5	
51SEF-3 <i>51SEF-3 IDMTL/DTL Sensitive Earth Fault operated</i>	Combination of (BO1, BO2, BO3, BO4, BO5, BO6, BO7, BO8, BO9, BO10, BO11, BO12, BO13, BO14, BO15, BO16, BO17, BO18, BO19, BO20, BO21, BO22, L1, L2, L3, L4, L5, L6, L7, L8, L9, L10, L11, L12, L13, L14, L15, L16, L17, L18, L19, L20, L21, L22, L23, L24, L25, L26, L27, L28, V1, V2, V3, V4, V5, V6, V7, V8, V9, V10, V11, V12, V13, V14)	L5	

Description	Range	Default	Setting
51SEF-4 <i>51SEF-4 IDMTL/DTL Sensitive Earth Fault operated</i>	Combination of (BO1, BO2, BO3, BO4, BO5, BO6, BO7, BO8, BO9, BO10, BO11, BO12, BO13, BO14, BO15, BO16, BO17, BO18, BO19, BO20, BO21, BO22, L1, L2, L3, L4, L5, L6, L7, L8, L9, L10, L11, L12, L13, L14, L15, L16, L17, L18, L19, L20, L21, L22, L23, L24, L25, L26, L27, L28, V1, V2, V3, V4, V5, V6, V7, V8, V9, V10, V11, V12, V13, V14)	L5	
50SEF-1 <i>50SEF-1 INST/DTL Sensitive Earth Fault operated</i>	Combination of (BO1, BO2, BO3, BO4, BO5, BO6, BO7, BO8, BO9, BO10, BO11, BO12, BO13, BO14, BO15, BO16, BO17, BO18, BO19, BO20, BO21, BO22, L1, L2, L3, L4, L5, L6, L7, L8, L9, L10, L11, L12, L13, L14, L15, L16, L17, L18, L19, L20, L21, L22, L23, L24, L25, L26, L27, L28, V1, V2, V3, V4, V5, V6, V7, V8, V9, V10, V11, V12, V13, V14)	L5	
50SEF-2 <i>50SEF-2 INST/DTL Sensitive Earth Fault operated</i>	Combination of (BO1, BO2, BO3, BO4, BO5, BO6, BO7, BO8, BO9, BO10, BO11, BO12, BO13, BO14, BO15, BO16, BO17, BO18, BO19, BO20, BO21, BO22, L1, L2, L3, L4, L5, L6, L7, L8, L9, L10, L11, L12, L13, L14, L15, L16, L17, L18, L19, L20, L21, L22, L23, L24, L25, L26, L27, L28, V1, V2, V3, V4, V5, V6, V7, V8, V9, V10, V11, V12, V13, V14)	L5	
50SEF-3 <i>50SEF-3 INST/DTL Sensitive Earth Fault operated</i>	Combination of (BO1, BO2, BO3, BO4, BO5, BO6, BO7, BO8, BO9, BO10, BO11, BO12, BO13, BO14, BO15, BO16, BO17, BO18, BO19, BO20, BO21, BO22, L1, L2, L3, L4, L5, L6, L7, L8, L9, L10, L11, L12, L13, L14, L15, L16, L17, L18, L19, L20, L21, L22, L23, L24, L25, L26, L27, L28, V1, V2, V3, V4, V5, V6, V7, V8, V9, V10, V11, V12, V13, V14)	L5	

Description	Range	Default	Setting
50SEF-4 <i>50SEF-4 INST/DTL Sensitive Earth Fault operated</i>	Combination of (BO1, BO2, BO3, BO4, BO5, BO6, BO7, BO8, BO9, BO10, BO11, BO12, BO13, BO14, BO15, BO16, BO17, BO18, BO19, BO20, BO21, BO22, L1, L2, L3, L4, L5, L6, L7, L8, L9, L10, L11, L12, L13, L14, L15, L16, L17, L18, L19, L20, L21, L22, L23, L24, L25, L26, L27, L28, V1, V2, V3, V4, V5, V6, V7, V8, V9, V10, V11, V12, V13, V14)	L5	
64H <i>64H Restricted Earth Fault element operated</i>	Combination of (BO1, BO2, BO3, BO4, BO5, BO6, BO7, BO8, BO9, BO10, BO11, BO12, BO13, BO14, BO15, BO16, BO17, BO18, BO19, BO20, BO21, BO22, L1, L2, L3, L4, L5, L6, L7, L8, L9, L10, L11, L12, L13, L14, L15, L16, L17, L18, L19, L20, L21, L22, L23, L24, L25, L26, L27, L28, V1, V2, V3, V4, V5, V6, V7, V8, V9, V10, V11, V12, V13, V14)	----- ----- ----- -----	
Cold Load Active <i>Cold Load settings are active</i>	Combination of (BO1, BO2, BO3, BO4, BO5, BO6, BO7, BO8, BO9, BO10, BO11, BO12, BO13, BO14, BO15, BO16, BO17, BO18, BO19, BO20, BO21, BO22, L1, L2, L3, L4, L5, L6, L7, L8, L9, L10, L11, L12, L13, L14, L15, L16, L17, L18, L19, L20, L21, L22, L23, L24, L25, L26, L27, L28, V1, V2, V3, V4, V5, V6, V7, V8, V9, V10, V11, V12, V13, V14)	----- ----- ----- -----	
46IT <i>IDMTL/DTL NPS Overcurrent operated</i>	Combination of (BO1, BO2, BO3, BO4, BO5, BO6, BO7, BO8, BO9, BO10, BO11, BO12, BO13, BO14, BO15, BO16, BO17, BO18, BO19, BO20, BO21, BO22, L1, L2, L3, L4, L5, L6, L7, L8, L9, L10, L11, L12, L13, L14, L15, L16, L17, L18, L19, L20, L21, L22, L23, L24, L25, L26, L27, L28, V1, V2, V3, V4, V5, V6, V7, V8, V9, V10, V11, V12, V13, V14)	----- ----- ----- -----	

Description	Range	Default	Setting
46DT <i>INST/DTL NPS Overcurrent operated</i>	Combination of (BO1, BO2, BO3, BO4, BO5, BO6, BO7, BO8, BO9, BO10, BO11, BO12, BO13, BO14, BO15, BO16, BO17, BO18, BO19, BO20, BO21, BO22, L1, L2, L3, L4, L5, L6, L7, L8, L9, L10, L11, L12, L13, L14, L15, L16, L17, L18, L19, L20, L21, L22, L23, L24, L25, L26, L27, L28, V1, V2, V3, V4, V5, V6, V7, V8, V9, V10, V11, V12, V13, V14)	----- ----- ----- -----	
37-1 <i>37-1 Under Current operated</i>	Combination of (BO1, BO2, BO3, BO4, BO5, BO6, BO7, BO8, BO9, BO10, BO11, BO12, BO13, BO14, BO15, BO16, BO17, BO18, BO19, BO20, BO21, BO22, L1, L2, L3, L4, L5, L6, L7, L8, L9, L10, L11, L12, L13, L14, L15, L16, L17, L18, L19, L20, L21, L22, L23, L24, L25, L26, L27, L28, V1, V2, V3, V4, V5, V6, V7, V8, V9, V10, V11, V12, V13, V14)	----- ----- ----- -----	
37-2 <i>37-2 Under Current operated</i>	Combination of (BO1, BO2, BO3, BO4, BO5, BO6, BO7, BO8, BO9, BO10, BO11, BO12, BO13, BO14, BO15, BO16, BO17, BO18, BO19, BO20, BO21, BO22, L1, L2, L3, L4, L5, L6, L7, L8, L9, L10, L11, L12, L13, L14, L15, L16, L17, L18, L19, L20, L21, L22, L23, L24, L25, L26, L27, L28, V1, V2, V3, V4, V5, V6, V7, V8, V9, V10, V11, V12, V13, V14)	----- ----- ----- -----	
49 Trip <i>Thermal capacity trip operated</i>	Combination of (BO1, BO2, BO3, BO4, BO5, BO6, BO7, BO8, BO9, BO10, BO11, BO12, BO13, BO14, BO15, BO16, BO17, BO18, BO19, BO20, BO21, BO22, L1, L2, L3, L4, L5, L6, L7, L8, L9, L10, L11, L12, L13, L14, L15, L16, L17, L18, L19, L20, L21, L22, L23, L24, L25, L26, L27, L28, V1, V2, V3, V4, V5, V6, V7, V8, V9, V10, V11, V12, V13, V14)	----- ----- ----- -----	

Description	Range	Default	Setting
49 Alarm <i>Thermal capacity alarm operated</i>	Combination of (BO1, BO2, BO3, BO4, BO5, BO6, BO7, BO8, BO9, BO10, BO11, BO12, BO13, BO14, BO15, BO16, BO17, BO18, BO19, BO20, BO21, BO22, L1, L2, L3, L4, L5, L6, L7, L8, L9, L10, L11, L12, L13, L14, L15, L16, L17, L18, L19, L20, L21, L22, L23, L24, L25, L26, L27, L28, V1, V2, V3, V4, V5, V6, V7, V8, V9, V10, V11, V12, V13, V14)	----- ----- ----- -----	
27/59-1 <i>Under/Overvoltage stage 1 operated</i>	Combination of (BO1, BO2, BO3, BO4, BO5, BO6, BO7, BO8, BO9, BO10, BO11, BO12, BO13, BO14, BO15, BO16, BO17, BO18, BO19, BO20, BO21, BO22, L1, L2, L3, L4, L5, L6, L7, L8, L9, L10, L11, L12, L13, L14, L15, L16, L17, L18, L19, L20, L21, L22, L23, L24, L25, L26, L27, L28, V1, V2, V3, V4, V5, V6, V7, V8, V9, V10, V11, V12, V13, V14)	----- ----- ----- -----	
27/59-2 <i>Under/Overvoltage stage 2 operated</i>	Combination of (BO1, BO2, BO3, BO4, BO5, BO6, BO7, BO8, BO9, BO10, BO11, BO12, BO13, BO14, BO15, BO16, BO17, BO18, BO19, BO20, BO21, BO22, L1, L2, L3, L4, L5, L6, L7, L8, L9, L10, L11, L12, L13, L14, L15, L16, L17, L18, L19, L20, L21, L22, L23, L24, L25, L26, L27, L28, V1, V2, V3, V4, V5, V6, V7, V8, V9, V10, V11, V12, V13, V14)	----- ----- ----- -----	
27/59-3 <i>Under/Overvoltage stage 3 operated</i>	Combination of (BO1, BO2, BO3, BO4, BO5, BO6, BO7, BO8, BO9, BO10, BO11, BO12, BO13, BO14, BO15, BO16, BO17, BO18, BO19, BO20, BO21, BO22, L1, L2, L3, L4, L5, L6, L7, L8, L9, L10, L11, L12, L13, L14, L15, L16, L17, L18, L19, L20, L21, L22, L23, L24, L25, L26, L27, L28, V1, V2, V3, V4, V5, V6, V7, V8, V9, V10, V11, V12, V13, V14)	----- ----- ----- -----	

Description	Range	Default	Setting
27/59-4 <i>Under/Overtension stage 4 operated</i>	Combination of (BO1, BO2, BO3, BO4, BO5, BO6, BO7, BO8, BO9, BO10, BO11, BO12, BO13, BO14, BO15, BO16, BO17, BO18, BO19, BO20, BO21, BO22, L1, L2, L3, L4, L5, L6, L7, L8, L9, L10, L11, L12, L13, L14, L15, L16, L17, L18, L19, L20, L21, L22, L23, L24, L25, L26, L27, L28, V1, V2, V3, V4, V5, V6, V7, V8, V9, V10, V11, V12, V13, V14)	----- ----- ----- -----	
Vx 27/59 <i>Under/Overtension Vx stage operated</i>	Combination of (BO1, BO2, BO3, BO4, BO5, BO6, BO7, BO8, BO9, BO10, BO11, BO12, BO13, BO14, BO15, BO16, BO17, BO18, BO19, BO20, BO21, BO22, L1, L2, L3, L4, L5, L6, L7, L8, L9, L10, L11, L12, L13, L14, L15, L16, L17, L18, L19, L20, L21, L22, L23, L24, L25, L26, L27, L28, V1, V2, V3, V4, V5, V6, V7, V8, V9, V10, V11, V12, V13, V14)	----- ----- ----- -----	
47-1 <i>INST/DTL NPS Overtension stage 1 operated</i>	Combination of (BO1, BO2, BO3, BO4, BO5, BO6, BO7, BO8, BO9, BO10, BO11, BO12, BO13, BO14, BO15, BO16, BO17, BO18, BO19, BO20, BO21, BO22, L1, L2, L3, L4, L5, L6, L7, L8, L9, L10, L11, L12, L13, L14, L15, L16, L17, L18, L19, L20, L21, L22, L23, L24, L25, L26, L27, L28, V1, V2, V3, V4, V5, V6, V7, V8, V9, V10, V11, V12, V13, V14)	----- ----- ----- -----	
47-2 <i>INST/DTL NPS Overtension stage 2 operated</i>	Combination of (BO1, BO2, BO3, BO4, BO5, BO6, BO7, BO8, BO9, BO10, BO11, BO12, BO13, BO14, BO15, BO16, BO17, BO18, BO19, BO20, BO21, BO22, L1, L2, L3, L4, L5, L6, L7, L8, L9, L10, L11, L12, L13, L14, L15, L16, L17, L18, L19, L20, L21, L22, L23, L24, L25, L26, L27, L28, V1, V2, V3, V4, V5, V6, V7, V8, V9, V10, V11, V12, V13, V14)	----- ----- ----- -----	

Description	Range	Default	Setting
59NIT <i>Neutral Overvoltage IDMTL/DTL operated</i>	Combination of (BO1, BO2, BO3, BO4, BO5, BO6, BO7, BO8, BO9, BO10, BO11, BO12, BO13, BO14, BO15, BO16, BO17, BO18, BO19, BO20, BO21, BO22, L1, L2, L3, L4, L5, L6, L7, L8, L9, L10, L11, L12, L13, L14, L15, L16, L17, L18, L19, L20, L21, L22, L23, L24, L25, L26, L27, L28, V1, V2, V3, V4, V5, V6, V7, V8, V9, V10, V11, V12, V13, V14)	----- ----- ----- -----	
59NDT <i>Neutral Overvoltage INST/DTL operated</i>	Combination of (BO1, BO2, BO3, BO4, BO5, BO6, BO7, BO8, BO9, BO10, BO11, BO12, BO13, BO14, BO15, BO16, BO17, BO18, BO19, BO20, BO21, BO22, L1, L2, L3, L4, L5, L6, L7, L8, L9, L10, L11, L12, L13, L14, L15, L16, L17, L18, L19, L20, L21, L22, L23, L24, L25, L26, L27, L28, V1, V2, V3, V4, V5, V6, V7, V8, V9, V10, V11, V12, V13, V14)	----- ----- ----- -----	
81-1 <i>Under/Over frequency stage 1 operated</i>	Combination of (BO1, BO2, BO3, BO4, BO5, BO6, BO7, BO8, BO9, BO10, BO11, BO12, BO13, BO14, BO15, BO16, BO17, BO18, BO19, BO20, BO21, BO22, L1, L2, L3, L4, L5, L6, L7, L8, L9, L10, L11, L12, L13, L14, L15, L16, L17, L18, L19, L20, L21, L22, L23, L24, L25, L26, L27, L28, V1, V2, V3, V4, V5, V6, V7, V8, V9, V10, V11, V12, V13, V14)	----- ----- ----- -----	
81-2 <i>Under/Over frequency stage 2 operated</i>	Combination of (BO1, BO2, BO3, BO4, BO5, BO6, BO7, BO8, BO9, BO10, BO11, BO12, BO13, BO14, BO15, BO16, BO17, BO18, BO19, BO20, BO21, BO22, L1, L2, L3, L4, L5, L6, L7, L8, L9, L10, L11, L12, L13, L14, L15, L16, L17, L18, L19, L20, L21, L22, L23, L24, L25, L26, L27, L28, V1, V2, V3, V4, V5, V6, V7, V8, V9, V10, V11, V12, V13, V14)	----- ----- ----- -----	

Description	Range	Default	Setting
81-3 <i>Under/Over frequency stage 3 operated</i>	Combination of (BO1, BO2, BO3, BO4, BO5, BO6, BO7, BO8, BO9, BO10, BO11, BO12, BO13, BO14, BO15, BO16, BO17, BO18, BO19, BO20, BO21, BO22, L1, L2, L3, L4, L5, L6, L7, L8, L9, L10, L11, L12, L13, L14, L15, L16, L17, L18, L19, L20, L21, L22, L23, L24, L25, L26, L27, L28, V1, V2, V3, V4, V5, V6, V7, V8, V9, V10, V11, V12, V13, V14)	----- ----- ----- -----	
81-4 <i>Under/Over frequency stage 4 operated</i>	Combination of (BO1, BO2, BO3, BO4, BO5, BO6, BO7, BO8, BO9, BO10, BO11, BO12, BO13, BO14, BO15, BO16, BO17, BO18, BO19, BO20, BO21, BO22, L1, L2, L3, L4, L5, L6, L7, L8, L9, L10, L11, L12, L13, L14, L15, L16, L17, L18, L19, L20, L21, L22, L23, L24, L25, L26, L27, L28, V1, V2, V3, V4, V5, V6, V7, V8, V9, V10, V11, V12, V13, V14)	----- ----- ----- -----	
60CTS <i>CT Supervision element operated</i>	Combination of (BO1, BO2, BO3, BO4, BO5, BO6, BO7, BO8, BO9, BO10, BO11, BO12, BO13, BO14, BO15, BO16, BO17, BO18, BO19, BO20, BO21, BO22, L1, L2, L3, L4, L5, L6, L7, L8, L9, L10, L11, L12, L13, L14, L15, L16, L17, L18, L19, L20, L21, L22, L23, L24, L25, L26, L27, L28, V1, V2, V3, V4, V5, V6, V7, V8, V9, V10, V11, V12, V13, V14)	----- ----- ----- -----	
46BC <i>46 Broken Conductor element operated</i>	Combination of (BO1, BO2, BO3, BO4, BO5, BO6, BO7, BO8, BO9, BO10, BO11, BO12, BO13, BO14, BO15, BO16, BO17, BO18, BO19, BO20, BO21, BO22, L1, L2, L3, L4, L5, L6, L7, L8, L9, L10, L11, L12, L13, L14, L15, L16, L17, L18, L19, L20, L21, L22, L23, L24, L25, L26, L27, L28, V1, V2, V3, V4, V5, V6, V7, V8, V9, V10, V11, V12, V13, V14)	----- ----- ----- -----	

Description	Range	Default	Setting
74TCS-1 <i>Trip Circuit 1 fail operated</i>	Combination of (BO1, BO2, BO3, BO4, BO5, BO6, BO7, BO8, BO9, BO10, BO11, BO12, BO13, BO14, BO15, BO16, BO17, BO18, BO19, BO20, BO21, BO22, L1, L2, L3, L4, L5, L6, L7, L8, L9, L10, L11, L12, L13, L14, L15, L16, L17, L18, L19, L20, L21, L22, L23, L24, L25, L26, L27, L28, V1, V2, V3, V4, V5, V6, V7, V8, V9, V10, V11, V12, V13, V14)	----- ----- ----- -----	
74TCS-2 <i>Trip Circuit 2 fail operated</i>	Combination of (BO1, BO2, BO3, BO4, BO5, BO6, BO7, BO8, BO9, BO10, BO11, BO12, BO13, BO14, BO15, BO16, BO17, BO18, BO19, BO20, BO21, BO22, L1, L2, L3, L4, L5, L6, L7, L8, L9, L10, L11, L12, L13, L14, L15, L16, L17, L18, L19, L20, L21, L22, L23, L24, L25, L26, L27, L28, V1, V2, V3, V4, V5, V6, V7, V8, V9, V10, V11, V12, V13, V14)	----- ----- ----- -----	
74TCS-3 <i>Trip Circuit 3 fail operated</i>	Combination of (BO1, BO2, BO3, BO4, BO5, BO6, BO7, BO8, BO9, BO10, BO11, BO12, BO13, BO14, BO15, BO16, BO17, BO18, BO19, BO20, BO21, BO22, L1, L2, L3, L4, L5, L6, L7, L8, L9, L10, L11, L12, L13, L14, L15, L16, L17, L18, L19, L20, L21, L22, L23, L24, L25, L26, L27, L28, V1, V2, V3, V4, V5, V6, V7, V8, V9, V10, V11, V12, V13, V14)	----- ----- ----- -----	
General Pickup <i>General Pickup operated</i>	Combination of (BO1, BO2, BO3, BO4, BO5, BO6, BO7, BO8, BO9, BO10, BO11, BO12, BO13, BO14, BO15, BO16, BO17, BO18, BO19, BO20, BO21, BO22, L1, L2, L3, L4, L5, L6, L7, L8, L9, L10, L11, L12, L13, L14, L15, L16, L17, L18, L19, L20, L21, L22, L23, L24, L25, L26, L27, L28, V1, V2, V3, V4, V5, V6, V7, V8, V9, V10, V11, V12, V13, V14)	----- ----- ----- -----	

Description	Range	Default	Setting
50BF-1 Pole A <i>Circuit Breaker Fail stage 1 operated</i>	Combination of (BO1, BO2, BO3, BO4, BO5, BO6, BO7, BO8, BO9, BO10, BO11, BO12, BO13, BO14, BO15, BO16, BO17, BO18, BO19, BO20, BO21, BO22, L1, L2, L3, L4, L5, L6, L7, L8, L9, L10, L11, L12, L13, L14, L15, L16, L17, L18, L19, L20, L21, L22, L23, L24, L25, L26, L27, L28, V1, V2, V3, V4, V5, V6, V7, V8, V9, V10, V11, V12, V13, V14)	----- ----- ----- -----	
50BF-1 Pole B <i>As Above</i>	Combination of (BO1, BO2, BO3, BO4, BO5, BO6, BO7, BO8, BO9, BO10, BO11, BO12, BO13, BO14, BO15, BO16, BO17, BO18, BO19, BO20, BO21, BO22, L1, L2, L3, L4, L5, L6, L7, L8, L9, L10, L11, L12, L13, L14, L15, L16, L17, L18, L19, L20, L21, L22, L23, L24, L25, L26, L27, L28, V1, V2, V3, V4, V5, V6, V7, V8, V9, V10, V11, V12, V13, V14)	----- ----- ----- -----	
50BF-1 Pole C <i>As Above</i>	Combination of (BO1, BO2, BO3, BO4, BO5, BO6, BO7, BO8, BO9, BO10, BO11, BO12, BO13, BO14, BO15, BO16, BO17, BO18, BO19, BO20, BO21, BO22, L1, L2, L3, L4, L5, L6, L7, L8, L9, L10, L11, L12, L13, L14, L15, L16, L17, L18, L19, L20, L21, L22, L23, L24, L25, L26, L27, L28, V1, V2, V3, V4, V5, V6, V7, V8, V9, V10, V11, V12, V13, V14)	----- ----- ----- -----	
50BF-2 Pole A <i>Circuit Breaker Fail stage 2 operated</i>	Combination of (BO1, BO2, BO3, BO4, BO5, BO6, BO7, BO8, BO9, BO10, BO11, BO12, BO13, BO14, BO15, BO16, BO17, BO18, BO19, BO20, BO21, BO22, L1, L2, L3, L4, L5, L6, L7, L8, L9, L10, L11, L12, L13, L14, L15, L16, L17, L18, L19, L20, L21, L22, L23, L24, L25, L26, L27, L28, V1, V2, V3, V4, V5, V6, V7, V8, V9, V10, V11, V12, V13, V14)	----- ----- ----- -----	

Description	Range	Default	Setting
50BF-2 Pole B <i>As Above</i>	Combination of (BO1, BO2, BO3, BO4, BO5, BO6, BO7, BO8, BO9, BO10, BO11, BO12, BO13, BO14, BO15, BO16, BO17, BO18, BO19, BO20, BO21, BO22, L1, L2, L3, L4, L5, L6, L7, L8, L9, L10, L11, L12, L13, L14, L15, L16, L17, L18, L19, L20, L21, L22, L23, L24, L25, L26, L27, L28, V1, V2, V3, V4, V5, V6, V7, V8, V9, V10, V11, V12, V13, V14)	----- ----- ----- -----	
50BF-2 Pole C <i>As Above</i>	Combination of (BO1, BO2, BO3, BO4, BO5, BO6, BO7, BO8, BO9, BO10, BO11, BO12, BO13, BO14, BO15, BO16, BO17, BO18, BO19, BO20, BO21, BO22, L1, L2, L3, L4, L5, L6, L7, L8, L9, L10, L11, L12, L13, L14, L15, L16, L17, L18, L19, L20, L21, L22, L23, L24, L25, L26, L27, L28, V1, V2, V3, V4, V5, V6, V7, V8, V9, V10, V11, V12, V13, V14)	----- ----- ----- -----	
60VTS <i>VT Supervision element operated</i>	Combination of (BO1, BO2, BO3, BO4, BO5, BO6, BO7, BO8, BO9, BO10, BO11, BO12, BO13, BO14, BO15, BO16, BO17, BO18, BO19, BO20, BO21, BO22, L1, L2, L3, L4, L5, L6, L7, L8, L9, L10, L11, L12, L13, L14, L15, L16, L17, L18, L19, L20, L21, L22, L23, L24, L25, L26, L27, L28, V1, V2, V3, V4, V5, V6, V7, V8, V9, V10, V11, V12, V13, V14)	----- ----- ----- -----	
CB-A Total TripCount <i>Total CB trip count exceeded</i>	Combination of (BO1, BO2, BO3, BO4, BO5, BO6, BO7, BO8, BO9, BO10, BO11, BO12, BO13, BO14, BO15, BO16, BO17, BO18, BO19, BO20, BO21, BO22, L1, L2, L3, L4, L5, L6, L7, L8, L9, L10, L11, L12, L13, L14, L15, L16, L17, L18, L19, L20, L21, L22, L23, L24, L25, L26, L27, L28, V1, V2, V3, V4, V5, V6, V7, V8, V9, V10, V11, V12, V13, V14)	----- ----- ----- -----	

Description	Range	Default	Setting
CB-B Total TripCount <i>As Above</i>	Combination of (BO1, BO2, BO3, BO4, BO5, BO6, BO7, BO8, BO9, BO10, BO11, BO12, BO13, BO14, BO15, BO16, BO17, BO18, BO19, BO20, BO21, BO22, L1, L2, L3, L4, L5, L6, L7, L8, L9, L10, L11, L12, L13, L14, L15, L16, L17, L18, L19, L20, L21, L22, L23, L24, L25, L26, L27, L28, V1, V2, V3, V4, V5, V6, V7, V8, V9, V10, V11, V12, V13, V14)	----- ----- ----- -----	
CB-C Total TripCount <i>As Above</i>	Combination of (BO1, BO2, BO3, BO4, BO5, BO6, BO7, BO8, BO9, BO10, BO11, BO12, BO13, BO14, BO15, BO16, BO17, BO18, BO19, BO20, BO21, BO22, L1, L2, L3, L4, L5, L6, L7, L8, L9, L10, L11, L12, L13, L14, L15, L16, L17, L18, L19, L20, L21, L22, L23, L24, L25, L26, L27, L28, V1, V2, V3, V4, V5, V6, V7, V8, V9, V10, V11, V12, V13, V14)	----- ----- ----- -----	
CB-A Delta TripCount <i>Delta CB trip count exceeded</i>	Combination of (BO1, BO2, BO3, BO4, BO5, BO6, BO7, BO8, BO9, BO10, BO11, BO12, BO13, BO14, BO15, BO16, BO17, BO18, BO19, BO20, BO21, BO22, L1, L2, L3, L4, L5, L6, L7, L8, L9, L10, L11, L12, L13, L14, L15, L16, L17, L18, L19, L20, L21, L22, L23, L24, L25, L26, L27, L28, V1, V2, V3, V4, V5, V6, V7, V8, V9, V10, V11, V12, V13, V14)	----- ----- ----- -----	
CB-B Delta TripCount <i>As Above</i>	Combination of (BO1, BO2, BO3, BO4, BO5, BO6, BO7, BO8, BO9, BO10, BO11, BO12, BO13, BO14, BO15, BO16, BO17, BO18, BO19, BO20, BO21, BO22, L1, L2, L3, L4, L5, L6, L7, L8, L9, L10, L11, L12, L13, L14, L15, L16, L17, L18, L19, L20, L21, L22, L23, L24, L25, L26, L27, L28, V1, V2, V3, V4, V5, V6, V7, V8, V9, V10, V11, V12, V13, V14)	----- ----- ----- -----	

Description	Range	Default	Setting
CB-C Delta TripCount <i>As Above</i>	Combination of (BO1, BO2, BO3, BO4, BO5, BO6, BO7, BO8, BO9, BO10, BO11, BO12, BO13, BO14, BO15, BO16, BO17, BO18, BO19, BO20, BO21, BO22, L1, L2, L3, L4, L5, L6, L7, L8, L9, L10, L11, L12, L13, L14, L15, L16, L17, L18, L19, L20, L21, L22, L23, L24, L25, L26, L27, L28, V1, V2, V3, V4, V5, V6, V7, V8, V9, V10, V11, V12, V13, V14)	----- ----- ----- -----	
CB-A Count - ARBlock <i>Count To AR Block CB trip count exceeded</i>	Combination of (BO1, BO2, BO3, BO4, BO5, BO6, BO7, BO8, BO9, BO10, BO11, BO12, BO13, BO14, BO15, BO16, BO17, BO18, BO19, BO20, BO21, BO22, L1, L2, L3, L4, L5, L6, L7, L8, L9, L10, L11, L12, L13, L14, L15, L16, L17, L18, L19, L20, L21, L22, L23, L24, L25, L26, L27, L28, V1, V2, V3, V4, V5, V6, V7, V8, V9, V10, V11, V12, V13, V14)	----- ----- ----- -----	
CB-B Count - ARBlock <i>As Above</i>	Combination of (BO1, BO2, BO3, BO4, BO5, BO6, BO7, BO8, BO9, BO10, BO11, BO12, BO13, BO14, BO15, BO16, BO17, BO18, BO19, BO20, BO21, BO22, L1, L2, L3, L4, L5, L6, L7, L8, L9, L10, L11, L12, L13, L14, L15, L16, L17, L18, L19, L20, L21, L22, L23, L24, L25, L26, L27, L28, V1, V2, V3, V4, V5, V6, V7, V8, V9, V10, V11, V12, V13, V14)	----- ----- ----- -----	
CB-C Count - ARBlock <i>As Above</i>	Combination of (BO1, BO2, BO3, BO4, BO5, BO6, BO7, BO8, BO9, BO10, BO11, BO12, BO13, BO14, BO15, BO16, BO17, BO18, BO19, BO20, BO21, BO22, L1, L2, L3, L4, L5, L6, L7, L8, L9, L10, L11, L12, L13, L14, L15, L16, L17, L18, L19, L20, L21, L22, L23, L24, L25, L26, L27, L28, V1, V2, V3, V4, V5, V6, V7, V8, V9, V10, V11, V12, V13, V14)	----- ----- ----- -----	

Description	Range	Default	Setting
CB-A Freq Ops Count <i>CB Frequent Operations count exceeded</i>	Combination of (BO1, BO2, BO3, BO4, BO5, BO6, BO7, BO8, BO9, BO10, BO11, BO12, BO13, BO14, BO15, BO16, BO17, BO18, BO19, BO20, BO21, BO22, L1, L2, L3, L4, L5, L6, L7, L8, L9, L10, L11, L12, L13, L14, L15, L16, L17, L18, L19, L20, L21, L22, L23, L24, L25, L26, L27, L28, V1, V2, V3, V4, V5, V6, V7, V8, V9, V10, V11, V12, V13, V14)	----- ----- ----- -----	
CB-B Freq Ops Count <i>As Above</i>	Combination of (BO1, BO2, BO3, BO4, BO5, BO6, BO7, BO8, BO9, BO10, BO11, BO12, BO13, BO14, BO15, BO16, BO17, BO18, BO19, BO20, BO21, BO22, L1, L2, L3, L4, L5, L6, L7, L8, L9, L10, L11, L12, L13, L14, L15, L16, L17, L18, L19, L20, L21, L22, L23, L24, L25, L26, L27, L28, V1, V2, V3, V4, V5, V6, V7, V8, V9, V10, V11, V12, V13, V14)	----- ----- ----- -----	
CB-C Freq Ops Count <i>As Above</i>	Combination of (BO1, BO2, BO3, BO4, BO5, BO6, BO7, BO8, BO9, BO10, BO11, BO12, BO13, BO14, BO15, BO16, BO17, BO18, BO19, BO20, BO21, BO22, L1, L2, L3, L4, L5, L6, L7, L8, L9, L10, L11, L12, L13, L14, L15, L16, L17, L18, L19, L20, L21, L22, L23, L24, L25, L26, L27, L28, V1, V2, V3, V4, V5, V6, V7, V8, V9, V10, V11, V12, V13, V14)	----- ----- ----- -----	
CB-A LO Handle Ops <i>CB Lockout Handle Operations count exceeded</i>	Combination of (BO1, BO2, BO3, BO4, BO5, BO6, BO7, BO8, BO9, BO10, BO11, BO12, BO13, BO14, BO15, BO16, BO17, BO18, BO19, BO20, BO21, BO22, L1, L2, L3, L4, L5, L6, L7, L8, L9, L10, L11, L12, L13, L14, L15, L16, L17, L18, L19, L20, L21, L22, L23, L24, L25, L26, L27, L28, V1, V2, V3, V4, V5, V6, V7, V8, V9, V10, V11, V12, V13, V14)	----- ----- ----- -----	

Description	Range	Default	Setting
CB-B LO Handle Ops <i>As Above</i>	Combination of (BO1, BO2, BO3, BO4, BO5, BO6, BO7, BO8, BO9, BO10, BO11, BO12, BO13, BO14, BO15, BO16, BO17, BO18, BO19, BO20, BO21, BO22, L1, L2, L3, L4, L5, L6, L7, L8, L9, L10, L11, L12, L13, L14, L15, L16, L17, L18, L19, L20, L21, L22, L23, L24, L25, L26, L27, L28, V1, V2, V3, V4, V5, V6, V7, V8, V9, V10, V11, V12, V13, V14)	----- ----- ----- -----	
CB-C LO Handle Ops <i>As Above</i>	Combination of (BO1, BO2, BO3, BO4, BO5, BO6, BO7, BO8, BO9, BO10, BO11, BO12, BO13, BO14, BO15, BO16, BO17, BO18, BO19, BO20, BO21, BO22, L1, L2, L3, L4, L5, L6, L7, L8, L9, L10, L11, L12, L13, L14, L15, L16, L17, L18, L19, L20, L21, L22, L23, L24, L25, L26, L27, L28, V1, V2, V3, V4, V5, V6, V7, V8, V9, V10, V11, V12, V13, V14)	----- ----- ----- -----	
I ² t CB-A Wear <i>I²t CB Wear limit exceeded</i>	Combination of (BO1, BO2, BO3, BO4, BO5, BO6, BO7, BO8, BO9, BO10, BO11, BO12, BO13, BO14, BO15, BO16, BO17, BO18, BO19, BO20, BO21, BO22, L1, L2, L3, L4, L5, L6, L7, L8, L9, L10, L11, L12, L13, L14, L15, L16, L17, L18, L19, L20, L21, L22, L23, L24, L25, L26, L27, L28, V1, V2, V3, V4, V5, V6, V7, V8, V9, V10, V11, V12, V13, V14)	----- ----- ----- -----	
I ² t CB-B Wear <i>As Above</i>	Combination of (BO1, BO2, BO3, BO4, BO5, BO6, BO7, BO8, BO9, BO10, BO11, BO12, BO13, BO14, BO15, BO16, BO17, BO18, BO19, BO20, BO21, BO22, L1, L2, L3, L4, L5, L6, L7, L8, L9, L10, L11, L12, L13, L14, L15, L16, L17, L18, L19, L20, L21, L22, L23, L24, L25, L26, L27, L28, V1, V2, V3, V4, V5, V6, V7, V8, V9, V10, V11, V12, V13, V14)	----- ----- ----- -----	

Description	Range	Default	Setting
I ² t CB-C Wear As Above	Combination of (BO1, BO2, BO3, BO4, BO5, BO6, BO7, BO8, BO9, BO10, BO11, BO12, BO13, BO14, BO15, BO16, BO17, BO18, BO19, BO20, BO21, BO22, L1, L2, L3, L4, L5, L6, L7, L8, L9, L10, L11, L12, L13, L14, L15, L16, L17, L18, L19, L20, L21, L22, L23, L24, L25, L26, L27, L28, V1, V2, V3, V4, V5, V6, V7, V8, V9, V10, V11, V12, V13, V14)	----- ----- ----- -----	
Battery Test <i>Battery Test is in progress. This can be used to disable battery charger during a battery test.</i>	Combination of (BO1, BO2, BO3, BO4, BO5, BO6, BO7, BO8, BO9, BO10, BO11, BO12, BO13, BO14, BO15, BO16, BO17, BO18, BO19, BO20, BO21, BO22, L1, L2, L3, L4, L5, L6, L7, L8, L9, L10, L11, L12, L13, L14, L15, L16, L17, L18, L19, L20, L21, L22, L23, L24, L25, L26, L27, L28, V1, V2, V3, V4, V5, V6, V7, V8, V9, V10, V11, V12, V13, V14)	----- ----- ----- -----	
Battery Load Test <i>Battery Load Test is in progress. This can be used to apply the battery test load during a battery test.</i>	Combination of (BO1, BO2, BO3, BO4, BO5, BO6, BO7, BO8, BO9, BO10, BO11, BO12, BO13, BO14, BO15, BO16, BO17, BO18, BO19, BO20, BO21, BO22, L1, L2, L3, L4, L5, L6, L7, L8, L9, L10, L11, L12, L13, L14, L15, L16, L17, L18, L19, L20, L21, L22, L23, L24, L25, L26, L27, L28, V1, V2, V3, V4, V5, V6, V7, V8, V9, V10, V11, V12, V13, V14)	----- ----- ----- -----	
Battery Test Pass <i>Indicates whether the last battery test passed.</i>	Combination of (BO1, BO2, BO3, BO4, BO5, BO6, BO7, BO8, BO9, BO10, BO11, BO12, BO13, BO14, BO15, BO16, BO17, BO18, BO19, BO20, BO21, BO22, L1, L2, L3, L4, L5, L6, L7, L8, L9, L10, L11, L12, L13, L14, L15, L16, L17, L18, L19, L20, L21, L22, L23, L24, L25, L26, L27, L28, V1, V2, V3, V4, V5, V6, V7, V8, V9, V10, V11, V12, V13, V14)	----- ----- ----- -----	

Description	Range	Default	Setting
<p>Battery Test Fail <i>Indicates whether the last battery test failed.</i></p>	<p>Combination of (BO1, BO2, BO3, BO4, BO5, BO6, BO7, BO8, BO9, BO10, BO11, BO12, BO13, BO14, BO15, BO16, BO17, BO18, BO19, BO20, BO21, BO22, L1, L2, L3, L4, L5, L6, L7, L8, L9, L10, L11, L12, L13, L14, L15, L16, L17, L18, L19, L20, L21, L22, L23, L24, L25, L26, L27, L28, V1, V2, V3, V4, V5, V6, V7, V8, V9, V10, V11, V12, V13, V14)</p>	<p>----- ----- ----- -----</p>	
<p>Recovery Fail <i>Indicates whether the battery failed to recover back to its pre-test voltage after last battery test.</i></p>	<p>Combination of (BO1, BO2, BO3, BO4, BO5, BO6, BO7, BO8, BO9, BO10, BO11, BO12, BO13, BO14, BO15, BO16, BO17, BO18, BO19, BO20, BO21, BO22, L1, L2, L3, L4, L5, L6, L7, L8, L9, L10, L11, L12, L13, L14, L15, L16, L17, L18, L19, L20, L21, L22, L23, L24, L25, L26, L27, L28, V1, V2, V3, V4, V5, V6, V7, V8, V9, V10, V11, V12, V13, V14)</p>	<p>----- ----- ----- -----</p>	
<p>Ext. Power Good <i>Indicates whether the external battery supply is ok.</i></p>	<p>Combination of (BO1, BO2, BO3, BO4, BO5, BO6, BO7, BO8, BO9, BO10, BO11, BO12, BO13, BO14, BO15, BO16, BO17, BO18, BO19, BO20, BO21, BO22, L1, L2, L3, L4, L5, L6, L7, L8, L9, L10, L11, L12, L13, L14, L15, L16, L17, L18, L19, L20, L21, L22, L23, L24, L25, L26, L27, L28, V1, V2, V3, V4, V5, V6, V7, V8, V9, V10, V11, V12, V13, V14)</p>	<p>----- ----- ----- -----</p>	
<p>Battery Healthy <i>Indicates whether the current battery voltage is healthy</i></p>	<p>Combination of (BO1, BO2, BO3, BO4, BO5, BO6, BO7, BO8, BO9, BO10, BO11, BO12, BO13, BO14, BO15, BO16, BO17, BO18, BO19, BO20, BO21, BO22, L1, L2, L3, L4, L5, L6, L7, L8, L9, L10, L11, L12, L13, L14, L15, L16, L17, L18, L19, L20, L21, L22, L23, L24, L25, L26, L27, L28, V1, V2, V3, V4, V5, V6, V7, V8, V9, V10, V11, V12, V13, V14)</p>	<p>----- ----- ----- -----</p>	

Description	Range	Default	Setting
<p>Cap-A Ready <i>Indicates whether the capacitor is ready to trip and close.</i></p>	<p>Combination of (BO1, BO2, BO3, BO4, BO5, BO6, BO7, BO8, BO9, BO10, BO11, BO12, BO13, BO14, BO15, BO16, BO17, BO18, BO19, BO20, BO21, BO22, L1, L2, L3, L4, L5, L6, L7, L8, L9, L10, L11, L12, L13, L14, L15, L16, L17, L18, L19, L20, L21, L22, L23, L24, L25, L26, L27, L28, V1, V2, V3, V4, V5, V6, V7, V8, V9, V10, V11, V12, V13, V14)</p>	<p>----- ----- ----- -----</p>	
<p>Cap-A Supply Fail <i>Indicates whether the current capacitor status is Supply Failed.</i></p>	<p>Combination of (BO1, BO2, BO3, BO4, BO5, BO6, BO7, BO8, BO9, BO10, BO11, BO12, BO13, BO14, BO15, BO16, BO17, BO18, BO19, BO20, BO21, BO22, L1, L2, L3, L4, L5, L6, L7, L8, L9, L10, L11, L12, L13, L14, L15, L16, L17, L18, L19, L20, L21, L22, L23, L24, L25, L26, L27, L28, V1, V2, V3, V4, V5, V6, V7, V8, V9, V10, V11, V12, V13, V14)</p>	<p>----- ----- ----- -----</p>	
<p>Cap-A Only Trip <i>Indicates whether the current capacitor status is Only Trip.</i></p>	<p>Combination of (BO1, BO2, BO3, BO4, BO5, BO6, BO7, BO8, BO9, BO10, BO11, BO12, BO13, BO14, BO15, BO16, BO17, BO18, BO19, BO20, BO21, BO22, L1, L2, L3, L4, L5, L6, L7, L8, L9, L10, L11, L12, L13, L14, L15, L16, L17, L18, L19, L20, L21, L22, L23, L24, L25, L26, L27, L28, V1, V2, V3, V4, V5, V6, V7, V8, V9, V10, V11, V12, V13, V14)</p>	<p>----- ----- ----- -----</p>	
<p>Cap-A DBI <i>Indicates whether the current capacitor status is DBI condition.</i></p>	<p>Combination of (BO1, BO2, BO3, BO4, BO5, BO6, BO7, BO8, BO9, BO10, BO11, BO12, BO13, BO14, BO15, BO16, BO17, BO18, BO19, BO20, BO21, BO22, L1, L2, L3, L4, L5, L6, L7, L8, L9, L10, L11, L12, L13, L14, L15, L16, L17, L18, L19, L20, L21, L22, L23, L24, L25, L26, L27, L28, V1, V2, V3, V4, V5, V6, V7, V8, V9, V10, V11, V12, V13, V14)</p>	<p>----- ----- ----- -----</p>	

Description	Range	Default	Setting
Cap-A Test Active <i>Capacitor Test is in progress.</i>	Combination of (BO1, BO2, BO3, BO4, BO5, BO6, BO7, BO8, BO9, BO10, BO11, BO12, BO13, BO14, BO15, BO16, BO17, BO18, BO19, BO20, BO21, BO22, L1, L2, L3, L4, L5, L6, L7, L8, L9, L10, L11, L12, L13, L14, L15, L16, L17, L18, L19, L20, L21, L22, L23, L24, L25, L26, L27, L28, V1, V2, V3, V4, V5, V6, V7, V8, V9, V10, V11, V12, V13, V14)	----- ----- ----- -----	
Cap-A Test Pass <i>Indicates whether the last capacitor test passed.</i>	Combination of (BO1, BO2, BO3, BO4, BO5, BO6, BO7, BO8, BO9, BO10, BO11, BO12, BO13, BO14, BO15, BO16, BO17, BO18, BO19, BO20, BO21, BO22, L1, L2, L3, L4, L5, L6, L7, L8, L9, L10, L11, L12, L13, L14, L15, L16, L17, L18, L19, L20, L21, L22, L23, L24, L25, L26, L27, L28, V1, V2, V3, V4, V5, V6, V7, V8, V9, V10, V11, V12, V13, V14)	----- ----- ----- -----	
Cap-A Test Fail <i>Indicates whether the last capacitor test failed.</i>	Combination of (BO1, BO2, BO3, BO4, BO5, BO6, BO7, BO8, BO9, BO10, BO11, BO12, BO13, BO14, BO15, BO16, BO17, BO18, BO19, BO20, BO21, BO22, L1, L2, L3, L4, L5, L6, L7, L8, L9, L10, L11, L12, L13, L14, L15, L16, L17, L18, L19, L20, L21, L22, L23, L24, L25, L26, L27, L28, V1, V2, V3, V4, V5, V6, V7, V8, V9, V10, V11, V12, V13, V14)	----- ----- ----- -----	
Cap-A Recovery Fail <i>Indicates whether the capacitor voltage failed to recover after the last capacitor test.</i>	Combination of (BO1, BO2, BO3, BO4, BO5, BO6, BO7, BO8, BO9, BO10, BO11, BO12, BO13, BO14, BO15, BO16, BO17, BO18, BO19, BO20, BO21, BO22, L1, L2, L3, L4, L5, L6, L7, L8, L9, L10, L11, L12, L13, L14, L15, L16, L17, L18, L19, L20, L21, L22, L23, L24, L25, L26, L27, L28, V1, V2, V3, V4, V5, V6, V7, V8, V9, V10, V11, V12, V13, V14)	----- ----- ----- -----	

Description	Range	Default	Setting
<p>Cap-B Ready <i>Indicates whether the capacitor is ready to trip and close.</i></p>	<p>Combination of (BO1, BO2, BO3, BO4, BO5, BO6, BO7, BO8, BO9, BO10, BO11, BO12, BO13, BO14, BO15, BO16, BO17, BO18, BO19, BO20, BO21, BO22, L1, L2, L3, L4, L5, L6, L7, L8, L9, L10, L11, L12, L13, L14, L15, L16, L17, L18, L19, L20, L21, L22, L23, L24, L25, L26, L27, L28, V1, V2, V3, V4, V5, V6, V7, V8, V9, V10, V11, V12, V13, V14)</p>	<p>----- ----- ----- -----</p>	
<p>Cap-B Supply Fail <i>Indicates whether the current capacitor status is Supply Failed.</i></p>	<p>Combination of (BO1, BO2, BO3, BO4, BO5, BO6, BO7, BO8, BO9, BO10, BO11, BO12, BO13, BO14, BO15, BO16, BO17, BO18, BO19, BO20, BO21, BO22, L1, L2, L3, L4, L5, L6, L7, L8, L9, L10, L11, L12, L13, L14, L15, L16, L17, L18, L19, L20, L21, L22, L23, L24, L25, L26, L27, L28, V1, V2, V3, V4, V5, V6, V7, V8, V9, V10, V11, V12, V13, V14)</p>	<p>----- ----- ----- -----</p>	
<p>Cap-B Only Trip <i>Indicates whether the current capacitor status is Only Trip.</i></p>	<p>Combination of (BO1, BO2, BO3, BO4, BO5, BO6, BO7, BO8, BO9, BO10, BO11, BO12, BO13, BO14, BO15, BO16, BO17, BO18, BO19, BO20, BO21, BO22, L1, L2, L3, L4, L5, L6, L7, L8, L9, L10, L11, L12, L13, L14, L15, L16, L17, L18, L19, L20, L21, L22, L23, L24, L25, L26, L27, L28, V1, V2, V3, V4, V5, V6, V7, V8, V9, V10, V11, V12, V13, V14)</p>	<p>----- ----- ----- -----</p>	
<p>Cap-B DBI <i>Indicates whether the current capacitor status is DBI condition.</i></p>	<p>Combination of (BO1, BO2, BO3, BO4, BO5, BO6, BO7, BO8, BO9, BO10, BO11, BO12, BO13, BO14, BO15, BO16, BO17, BO18, BO19, BO20, BO21, BO22, L1, L2, L3, L4, L5, L6, L7, L8, L9, L10, L11, L12, L13, L14, L15, L16, L17, L18, L19, L20, L21, L22, L23, L24, L25, L26, L27, L28, V1, V2, V3, V4, V5, V6, V7, V8, V9, V10, V11, V12, V13, V14)</p>	<p>----- ----- ----- -----</p>	

Description	Range	Default	Setting
<p>Cap-B Test Active <i>Capacitor Test is in progress.</i></p>	<p>Combination of (BO1, BO2, BO3, BO4, BO5, BO6, BO7, BO8, BO9, BO10, BO11, BO12, BO13, BO14, BO15, BO16, BO17, BO18, BO19, BO20, BO21, BO22, L1, L2, L3, L4, L5, L6, L7, L8, L9, L10, L11, L12, L13, L14, L15, L16, L17, L18, L19, L20, L21, L22, L23, L24, L25, L26, L27, L28, V1, V2, V3, V4, V5, V6, V7, V8, V9, V10, V11, V12, V13, V14)</p>	<p>----- ----- ----- -----</p>	
<p>Cap-B Test Pass <i>Indicates whether the last capacitor test passed.</i></p>	<p>Combination of (BO1, BO2, BO3, BO4, BO5, BO6, BO7, BO8, BO9, BO10, BO11, BO12, BO13, BO14, BO15, BO16, BO17, BO18, BO19, BO20, BO21, BO22, L1, L2, L3, L4, L5, L6, L7, L8, L9, L10, L11, L12, L13, L14, L15, L16, L17, L18, L19, L20, L21, L22, L23, L24, L25, L26, L27, L28, V1, V2, V3, V4, V5, V6, V7, V8, V9, V10, V11, V12, V13, V14)</p>	<p>----- ----- ----- -----</p>	
<p>Cap-B Test Fail <i>Indicates whether the last capacitor test failed.</i></p>	<p>Combination of (BO1, BO2, BO3, BO4, BO5, BO6, BO7, BO8, BO9, BO10, BO11, BO12, BO13, BO14, BO15, BO16, BO17, BO18, BO19, BO20, BO21, BO22, L1, L2, L3, L4, L5, L6, L7, L8, L9, L10, L11, L12, L13, L14, L15, L16, L17, L18, L19, L20, L21, L22, L23, L24, L25, L26, L27, L28, V1, V2, V3, V4, V5, V6, V7, V8, V9, V10, V11, V12, V13, V14)</p>	<p>----- ----- ----- -----</p>	
<p>Cap-B Recovery Fail <i>Indicates whether the capacitor voltage failed to recover after the last capacitor test.</i></p>	<p>Combination of (BO1, BO2, BO3, BO4, BO5, BO6, BO7, BO8, BO9, BO10, BO11, BO12, BO13, BO14, BO15, BO16, BO17, BO18, BO19, BO20, BO21, BO22, L1, L2, L3, L4, L5, L6, L7, L8, L9, L10, L11, L12, L13, L14, L15, L16, L17, L18, L19, L20, L21, L22, L23, L24, L25, L26, L27, L28, V1, V2, V3, V4, V5, V6, V7, V8, V9, V10, V11, V12, V13, V14)</p>	<p>----- ----- ----- -----</p>	

Description	Range	Default	Setting
<p>Cap-C Ready <i>Indicates whether the capacitor is ready to trip and close.</i></p>	<p>Combination of (BO1, BO2, BO3, BO4, BO5, BO6, BO7, BO8, BO9, BO10, BO11, BO12, BO13, BO14, BO15, BO16, BO17, BO18, BO19, BO20, BO21, BO22, L1, L2, L3, L4, L5, L6, L7, L8, L9, L10, L11, L12, L13, L14, L15, L16, L17, L18, L19, L20, L21, L22, L23, L24, L25, L26, L27, L28, V1, V2, V3, V4, V5, V6, V7, V8, V9, V10, V11, V12, V13, V14)</p>	<p>----- ----- ----- -----</p>	
<p>Cap-C Supply Fail <i>Indicates whether the current capacitor status is Supply Failed.</i></p>	<p>Combination of (BO1, BO2, BO3, BO4, BO5, BO6, BO7, BO8, BO9, BO10, BO11, BO12, BO13, BO14, BO15, BO16, BO17, BO18, BO19, BO20, BO21, BO22, L1, L2, L3, L4, L5, L6, L7, L8, L9, L10, L11, L12, L13, L14, L15, L16, L17, L18, L19, L20, L21, L22, L23, L24, L25, L26, L27, L28, V1, V2, V3, V4, V5, V6, V7, V8, V9, V10, V11, V12, V13, V14)</p>	<p>----- ----- ----- -----</p>	
<p>Cap-C Only Trip <i>Indicates whether the current capacitor status is Only Trip.</i></p>	<p>Combination of (BO1, BO2, BO3, BO4, BO5, BO6, BO7, BO8, BO9, BO10, BO11, BO12, BO13, BO14, BO15, BO16, BO17, BO18, BO19, BO20, BO21, BO22, L1, L2, L3, L4, L5, L6, L7, L8, L9, L10, L11, L12, L13, L14, L15, L16, L17, L18, L19, L20, L21, L22, L23, L24, L25, L26, L27, L28, V1, V2, V3, V4, V5, V6, V7, V8, V9, V10, V11, V12, V13, V14)</p>	<p>----- ----- ----- -----</p>	
<p>Cap-C DBI <i>Indicates whether the current capacitor status is DBI condition.</i></p>	<p>Combination of (BO1, BO2, BO3, BO4, BO5, BO6, BO7, BO8, BO9, BO10, BO11, BO12, BO13, BO14, BO15, BO16, BO17, BO18, BO19, BO20, BO21, BO22, L1, L2, L3, L4, L5, L6, L7, L8, L9, L10, L11, L12, L13, L14, L15, L16, L17, L18, L19, L20, L21, L22, L23, L24, L25, L26, L27, L28, V1, V2, V3, V4, V5, V6, V7, V8, V9, V10, V11, V12, V13, V14)</p>	<p>----- ----- ----- -----</p>	

Description	Range	Default	Setting
<p>Cap-C Test Active <i>Capacitor Test is in progress.</i></p>	<p>Combination of (BO1, BO2, BO3, BO4, BO5, BO6, BO7, BO8, BO9, BO10, BO11, BO12, BO13, BO14, BO15, BO16, BO17, BO18, BO19, BO20, BO21, BO22, L1, L2, L3, L4, L5, L6, L7, L8, L9, L10, L11, L12, L13, L14, L15, L16, L17, L18, L19, L20, L21, L22, L23, L24, L25, L26, L27, L28, V1, V2, V3, V4, V5, V6, V7, V8, V9, V10, V11, V12, V13, V14)</p>	<p>----- ----- ----- -----</p>	
<p>Cap-C Test Pass <i>Indicates whether the last capacitor test passed.</i></p>	<p>Combination of (BO1, BO2, BO3, BO4, BO5, BO6, BO7, BO8, BO9, BO10, BO11, BO12, BO13, BO14, BO15, BO16, BO17, BO18, BO19, BO20, BO21, BO22, L1, L2, L3, L4, L5, L6, L7, L8, L9, L10, L11, L12, L13, L14, L15, L16, L17, L18, L19, L20, L21, L22, L23, L24, L25, L26, L27, L28, V1, V2, V3, V4, V5, V6, V7, V8, V9, V10, V11, V12, V13, V14)</p>	<p>----- ----- ----- -----</p>	
<p>Cap-C Test Fail <i>Indicates whether the last capacitor test failed.</i></p>	<p>Combination of (BO1, BO2, BO3, BO4, BO5, BO6, BO7, BO8, BO9, BO10, BO11, BO12, BO13, BO14, BO15, BO16, BO17, BO18, BO19, BO20, BO21, BO22, L1, L2, L3, L4, L5, L6, L7, L8, L9, L10, L11, L12, L13, L14, L15, L16, L17, L18, L19, L20, L21, L22, L23, L24, L25, L26, L27, L28, V1, V2, V3, V4, V5, V6, V7, V8, V9, V10, V11, V12, V13, V14)</p>	<p>----- ----- ----- -----</p>	
<p>Cap-C Recovery Fail <i>Indicates whether the capacitor voltage failed to recover after the last capacitor test.</i></p>	<p>Combination of (BO1, BO2, BO3, BO4, BO5, BO6, BO7, BO8, BO9, BO10, BO11, BO12, BO13, BO14, BO15, BO16, BO17, BO18, BO19, BO20, BO21, BO22, L1, L2, L3, L4, L5, L6, L7, L8, L9, L10, L11, L12, L13, L14, L15, L16, L17, L18, L19, L20, L21, L22, L23, L24, L25, L26, L27, L28, V1, V2, V3, V4, V5, V6, V7, V8, V9, V10, V11, V12, V13, V14)</p>	<p>----- ----- ----- -----</p>	

Description	Range	Default	Setting
<p>Capacitors Ready</p> <p><i>Indicates whether the all capacitors are ready to trip and close.</i></p>	<p>Combination of (BO1, BO2, BO3, BO4, BO5, BO6, BO7, BO8, BO9, BO10, BO11, BO12, BO13, BO14, BO15, BO16, BO17, BO18, BO19, BO20, BO21, BO22, L1, L2, L3, L4, L5, L6, L7, L8, L9, L10, L11, L12, L13, L14, L15, L16, L17, L18, L19, L20, L21, L22, L23, L24, L25, L26, L27, L28, V1, V2, V3, V4, V5, V6, V7, V8, V9, V10, V11, V12, V13, V14)</p>	<p>----- ----- ----- -----</p>	
<p>27Sag Pole1 SARFI</p> <p><i>Voltage has dropped below the defined SARFI level on Pole 1.</i></p>	<p>Combination of (BO1, BO2, BO3, BO4, BO5, BO6, BO7, BO8, BO9, BO10, BO11, BO12, BO13, BO14, BO15, BO16, BO17, BO18, BO19, BO20, BO21, BO22, L1, L2, L3, L4, L5, L6, L7, L8, L9, L10, L11, L12, L13, L14, L15, L16, L17, L18, L19, L20, L21, L22, L23, L24, L25, L26, L27, L28, V1, V2, V3, V4, V5, V6, V7, V8, V9, V10, V11, V12, V13, V14)</p>	<p>----- ----- ----- -----</p>	
<p>27Sag Pole2 SARFI</p> <p><i>Voltage has dropped below the defined SARFI level on Pole 2.</i></p>	<p>Combination of (BO1, BO2, BO3, BO4, BO5, BO6, BO7, BO8, BO9, BO10, BO11, BO12, BO13, BO14, BO15, BO16, BO17, BO18, BO19, BO20, BO21, BO22, L1, L2, L3, L4, L5, L6, L7, L8, L9, L10, L11, L12, L13, L14, L15, L16, L17, L18, L19, L20, L21, L22, L23, L24, L25, L26, L27, L28, V1, V2, V3, V4, V5, V6, V7, V8, V9, V10, V11, V12, V13, V14)</p>	<p>----- ----- ----- -----</p>	
<p>27Sag Pole3 SARFI</p> <p><i>Voltage has dropped below the defined SARFI level on Pole 3.</i></p>	<p>Combination of (BO1, BO2, BO3, BO4, BO5, BO6, BO7, BO8, BO9, BO10, BO11, BO12, BO13, BO14, BO15, BO16, BO17, BO18, BO19, BO20, BO21, BO22, L1, L2, L3, L4, L5, L6, L7, L8, L9, L10, L11, L12, L13, L14, L15, L16, L17, L18, L19, L20, L21, L22, L23, L24, L25, L26, L27, L28, V1, V2, V3, V4, V5, V6, V7, V8, V9, V10, V11, V12, V13, V14)</p>	<p>----- ----- ----- -----</p>	

Description	Range	Default	Setting
59Swell Pole1 SARFI <i>Voltage has risen above the defined SARFI level on Pole 1.</i>	Combination of (BO1, BO2, BO3, BO4, BO5, BO6, BO7, BO8, BO9, BO10, BO11, BO12, BO13, BO14, BO15, BO16, BO17, BO18, BO19, BO20, BO21, BO22, L1, L2, L3, L4, L5, L6, L7, L8, L9, L10, L11, L12, L13, L14, L15, L16, L17, L18, L19, L20, L21, L22, L23, L24, L25, L26, L27, L28, V1, V2, V3, V4, V5, V6, V7, V8, V9, V10, V11, V12, V13, V14)	----- ----- ----- -----	
59Swell Pole2 SARFI <i>Voltage has risen above the defined SARFI level on Pole 2.</i>	Combination of (BO1, BO2, BO3, BO4, BO5, BO6, BO7, BO8, BO9, BO10, BO11, BO12, BO13, BO14, BO15, BO16, BO17, BO18, BO19, BO20, BO21, BO22, L1, L2, L3, L4, L5, L6, L7, L8, L9, L10, L11, L12, L13, L14, L15, L16, L17, L18, L19, L20, L21, L22, L23, L24, L25, L26, L27, L28, V1, V2, V3, V4, V5, V6, V7, V8, V9, V10, V11, V12, V13, V14)	----- ----- ----- -----	
59Swell Pole3 SARFI <i>Voltage has risen above the defined SARFI level on Pole 3.</i>	Combination of (BO1, BO2, BO3, BO4, BO5, BO6, BO7, BO8, BO9, BO10, BO11, BO12, BO13, BO14, BO15, BO16, BO17, BO18, BO19, BO20, BO21, BO22, L1, L2, L3, L4, L5, L6, L7, L8, L9, L10, L11, L12, L13, L14, L15, L16, L17, L18, L19, L20, L21, L22, L23, L24, L25, L26, L27, L28, V1, V2, V3, V4, V5, V6, V7, V8, V9, V10, V11, V12, V13, V14)	----- ----- ----- -----	
Phase A <i>A phase A element operated</i>	Combination of (BO1, BO2, BO3, BO4, BO5, BO6, BO7, BO8, BO9, BO10, BO11, BO12, BO13, BO14, BO15, BO16, BO17, BO18, BO19, BO20, BO21, BO22, L1, L2, L3, L4, L5, L6, L7, L8, L9, L10, L11, L12, L13, L14, L15, L16, L17, L18, L19, L20, L21, L22, L23, L24, L25, L26, L27, L28, V1, V2, V3, V4, V5, V6, V7, V8, V9, V10, V11, V12, V13, V14)	----- ----- ----- -----	

Description	Range	Default	Setting
Phase B <i>A phase B element operated</i>	Combination of (BO1, BO2, BO3, BO4, BO5, BO6, BO7, BO8, BO9, BO10, BO11, BO12, BO13, BO14, BO15, BO16, BO17, BO18, BO19, BO20, BO21, BO22, L1, L2, L3, L4, L5, L6, L7, L8, L9, L10, L11, L12, L13, L14, L15, L16, L17, L18, L19, L20, L21, L22, L23, L24, L25, L26, L27, L28, V1, V2, V3, V4, V5, V6, V7, V8, V9, V10, V11, V12, V13, V14)	----- ----- ----- -----	
Phase C <i>A phase C element operated</i>	Combination of (BO1, BO2, BO3, BO4, BO5, BO6, BO7, BO8, BO9, BO10, BO11, BO12, BO13, BO14, BO15, BO16, BO17, BO18, BO19, BO20, BO21, BO22, L1, L2, L3, L4, L5, L6, L7, L8, L9, L10, L11, L12, L13, L14, L15, L16, L17, L18, L19, L20, L21, L22, L23, L24, L25, L26, L27, L28, V1, V2, V3, V4, V5, V6, V7, V8, V9, V10, V11, V12, V13, V14)	----- ----- ----- -----	
Forward P/F <i>The Phase fault is in the forward direction. Note this output is presented EVEN when relay elements are set to be non-directional.</i>	Combination of (BO1, BO2, BO3, BO4, BO5, BO6, BO7, BO8, BO9, BO10, BO11, BO12, BO13, BO14, BO15, BO16, BO17, BO18, BO19, BO20, BO21, BO22, L1, L2, L3, L4, L5, L6, L7, L8, L9, L10, L11, L12, L13, L14, L15, L16, L17, L18, L19, L20, L21, L22, L23, L24, L25, L26, L27, L28, V1, V2, V3, V4, V5, V6, V7, V8, V9, V10, V11, V12, V13, V14)	----- ----- ----- -----	
Reverse P/F <i>The Phase fault is in the reverse direction. Note this output is presented EVEN when relay elements are set to be non-directional.</i>	Combination of (BO1, BO2, BO3, BO4, BO5, BO6, BO7, BO8, BO9, BO10, BO11, BO12, BO13, BO14, BO15, BO16, BO17, BO18, BO19, BO20, BO21, BO22, L1, L2, L3, L4, L5, L6, L7, L8, L9, L10, L11, L12, L13, L14, L15, L16, L17, L18, L19, L20, L21, L22, L23, L24, L25, L26, L27, L28, V1, V2, V3, V4, V5, V6, V7, V8, V9, V10, V11, V12, V13, V14)	----- ----- ----- -----	

Description	Range	Default	Setting
<p>Forward E/F</p> <p><i>The fault is in the forward direction. Note this output is presented EVEN when relay elements are set to be non-directional.</i></p>	<p>Combination of (BO1, BO2, BO3, BO4, BO5, BO6, BO7, BO8, BO9, BO10, BO11, BO12, BO13, BO14, BO15, BO16, BO17, BO18, BO19, BO20, BO21, BO22, L1, L2, L3, L4, L5, L6, L7, L8, L9, L10, L11, L12, L13, L14, L15, L16, L17, L18, L19, L20, L21, L22, L23, L24, L25, L26, L27, L28, V1, V2, V3, V4, V5, V6, V7, V8, V9, V10, V11, V12, V13, V14)</p>	<p>----- ----- ----- -----</p>	
<p>Reverse E/F</p> <p><i>The fault is in the reverse direction. Note this output is presented EVEN when relay elements are set to be non-directional.</i></p>	<p>Combination of (BO1, BO2, BO3, BO4, BO5, BO6, BO7, BO8, BO9, BO10, BO11, BO12, BO13, BO14, BO15, BO16, BO17, BO18, BO19, BO20, BO21, BO22, L1, L2, L3, L4, L5, L6, L7, L8, L9, L10, L11, L12, L13, L14, L15, L16, L17, L18, L19, L20, L21, L22, L23, L24, L25, L26, L27, L28, V1, V2, V3, V4, V5, V6, V7, V8, V9, V10, V11, V12, V13, V14)</p>	<p>----- ----- ----- -----</p>	
<p>Forward SEF</p> <p><i>The fault is in the forward direction. Note this output is presented EVEN when relay elements are set to be non-directional.</i></p>	<p>Combination of (BO1, BO2, BO3, BO4, BO5, BO6, BO7, BO8, BO9, BO10, BO11, BO12, BO13, BO14, BO15, BO16, BO17, BO18, BO19, BO20, BO21, BO22, L1, L2, L3, L4, L5, L6, L7, L8, L9, L10, L11, L12, L13, L14, L15, L16, L17, L18, L19, L20, L21, L22, L23, L24, L25, L26, L27, L28, V1, V2, V3, V4, V5, V6, V7, V8, V9, V10, V11, V12, V13, V14)</p>	<p>----- ----- ----- -----</p>	
<p>Reverse SEF</p> <p><i>The fault is in the reverse direction. Note this output is presented EVEN when relay elements are set to be non-directional.</i></p>	<p>Combination of (BO1, BO2, BO3, BO4, BO5, BO6, BO7, BO8, BO9, BO10, BO11, BO12, BO13, BO14, BO15, BO16, BO17, BO18, BO19, BO20, BO21, BO22, L1, L2, L3, L4, L5, L6, L7, L8, L9, L10, L11, L12, L13, L14, L15, L16, L17, L18, L19, L20, L21, L22, L23, L24, L25, L26, L27, L28, V1, V2, V3, V4, V5, V6, V7, V8, V9, V10, V11, V12, V13, V14)</p>	<p>----- ----- ----- -----</p>	

Description	Range	Default	Setting
Pole A Trip <i>Indicates that a Pole A Trip is required and should be mapped to the Pole A Trip contact</i>	Combination of (BO1, BO2, BO3, BO4, BO5, BO6, BO7, BO8, BO9, BO10, BO11, BO12, BO13, BO14, BO15, BO16, BO17, BO18, BO19, BO20, BO21, BO22, L1, L2, L3, L4, L5, L6, L7, L8, L9, L10, L11, L12, L13, L14, L15, L16, L17, L18, L19, L20, L21, L22, L23, L24, L25, L26, L27, L28, V1, V2, V3, V4, V5, V6, V7, V8, V9, V10, V11, V12, V13, V14)	L1	
Pole B Trip <i>Indicates that a Pole B Trip is required and should be mapped to the Pole B Trip contact</i>	Combination of (BO1, BO2, BO3, BO4, BO5, BO6, BO7, BO8, BO9, BO10, BO11, BO12, BO13, BO14, BO15, BO16, BO17, BO18, BO19, BO20, BO21, BO22, L1, L2, L3, L4, L5, L6, L7, L8, L9, L10, L11, L12, L13, L14, L15, L16, L17, L18, L19, L20, L21, L22, L23, L24, L25, L26, L27, L28, V1, V2, V3, V4, V5, V6, V7, V8, V9, V10, V11, V12, V13, V14)	L2	
Pole C Trip <i>Indicates that a Pole C Trip is required and should be mapped to the Pole C Trip contact</i>	Combination of (BO1, BO2, BO3, BO4, BO5, BO6, BO7, BO8, BO9, BO10, BO11, BO12, BO13, BO14, BO15, BO16, BO17, BO18, BO19, BO20, BO21, BO22, L1, L2, L3, L4, L5, L6, L7, L8, L9, L10, L11, L12, L13, L14, L15, L16, L17, L18, L19, L20, L21, L22, L23, L24, L25, L26, L27, L28, V1, V2, V3, V4, V5, V6, V7, V8, V9, V10, V11, V12, V13, V14)	L3	
Mode A - 3PTrip3PLO <i>Selects which inputs will Set the relay to operate in Mode A (3 pole Trip & 3 pole lockout).</i>	Combination of (BO1, BO2, BO3, BO4, BO5, BO6, BO7, BO8, BO9, BO10, BO11, BO12, BO13, BO14, BO15, BO16, BO17, BO18, BO19, BO20, BO21, BO22, L1, L2, L3, L4, L5, L6, L7, L8, L9, L10, L11, L12, L13, L14, L15, L16, L17, L18, L19, L20, L21, L22, L23, L24, L25, L26, L27, L28, V1, V2, V3, V4, V5, V6, V7, V8, V9, V10, V11, V12, V13, V14)	----- ----- ----- -----	

Description	Range	Default	Setting
<p>Mode B - 1PTrip3PLO <i>Selects which inputs will Set the relay to operate in Mode B (1 pole Trip & 3 pole lockout).</i></p>	<p>Combination of (BO1, BO2, BO3, BO4, BO5, BO6, BO7, BO8, BO9, BO10, BO11, BO12, BO13, BO14, BO15, BO16, BO17, BO18, BO19, BO20, BO21, BO22, L1, L2, L3, L4, L5, L6, L7, L8, L9, L10, L11, L12, L13, L14, L15, L16, L17, L18, L19, L20, L21, L22, L23, L24, L25, L26, L27, L28, V1, V2, V3, V4, V5, V6, V7, V8, V9, V10, V11, V12, V13, V14)</p>	<p>----- ----- ----- -----</p>	
<p>Mode C - 1PTrip1PLO <i>Selects which inputs will Set the relay to operate in Mode C (1 pole Trip & 1 pole lockout).</i></p>	<p>Combination of (BO1, BO2, BO3, BO4, BO5, BO6, BO7, BO8, BO9, BO10, BO11, BO12, BO13, BO14, BO15, BO16, BO17, BO18, BO19, BO20, BO21, BO22, L1, L2, L3, L4, L5, L6, L7, L8, L9, L10, L11, L12, L13, L14, L15, L16, L17, L18, L19, L20, L21, L22, L23, L24, L25, L26, L27, L28, V1, V2, V3, V4, V5, V6, V7, V8, V9, V10, V11, V12, V13, V14)</p>	<p>----- ----- ----- -----</p>	
<p>Close CB-A Blocked <i>Indicates that the Close CB control is blocked by its interlocking logic.</i></p>	<p>Combination of (BO1, BO2, BO3, BO4, BO5, BO6, BO7, BO8, BO9, BO10, BO11, BO12, BO13, BO14, BO15, BO16, BO17, BO18, BO19, BO20, BO21, BO22, L1, L2, L3, L4, L5, L6, L7, L8, L9, L10, L11, L12, L13, L14, L15, L16, L17, L18, L19, L20, L21, L22, L23, L24, L25, L26, L27, L28, V1, V2, V3, V4, V5, V6, V7, V8, V9, V10, V11, V12, V13, V14)</p>	<p>----- ----- ----- -----</p>	
<p>Open CB-A <i>Selects which inputs will issue an open to the circuit breaker.</i></p>	<p>Combination of (BO1, BO2, BO3, BO4, BO5, BO6, BO7, BO8, BO9, BO10, BO11, BO12, BO13, BO14, BO15, BO16, BO17, BO18, BO19, BO20, BO21, BO22, L1, L2, L3, L4, L5, L6, L7, L8, L9, L10, L11, L12, L13, L14, L15, L16, L17, L18, L19, L20, L21, L22, L23, L24, L25, L26, L27, L28, V1, V2, V3, V4, V5, V6, V7, V8, V9, V10, V11, V12, V13, V14)</p>	<p>----- ----- ----- -----</p>	

Description	Range	Default	Setting
<p>CB-A Alarm <i>Indicates the CB is either in an illegal state or is stuck neither open or closed.</i></p>	<p>Combination of (BO1, BO2, BO3, BO4, BO5, BO6, BO7, BO8, BO9, BO10, BO11, BO12, BO13, BO14, BO15, BO16, BO17, BO18, BO19, BO20, BO21, BO22, L1, L2, L3, L4, L5, L6, L7, L8, L9, L10, L11, L12, L13, L14, L15, L16, L17, L18, L19, L20, L21, L22, L23, L24, L25, L26, L27, L28, V1, V2, V3, V4, V5, V6, V7, V8, V9, V10, V11, V12, V13, V14)</p>	<p>----- ----- ----- -----</p>	
<p>CB-A Closed <i>Selects which inputs are connected to the circuit breaker closed contacts</i></p>	<p>Combination of (BO1, BO2, BO3, BO4, BO5, BO6, BO7, BO8, BO9, BO10, BO11, BO12, BO13, BO14, BO15, BO16, BO17, BO18, BO19, BO20, BO21, BO22, L1, L2, L3, L4, L5, L6, L7, L8, L9, L10, L11, L12, L13, L14, L15, L16, L17, L18, L19, L20, L21, L22, L23, L24, L25, L26, L27, L28, V1, V2, V3, V4, V5, V6, V7, V8, V9, V10, V11, V12, V13, V14)</p>	<p>----- ----- ----- -----</p>	
<p>CB-A Open <i>Selects which inputs are connected to the circuit breaker open contacts</i></p>	<p>Combination of (BO1, BO2, BO3, BO4, BO5, BO6, BO7, BO8, BO9, BO10, BO11, BO12, BO13, BO14, BO15, BO16, BO17, BO18, BO19, BO20, BO21, BO22, L1, L2, L3, L4, L5, L6, L7, L8, L9, L10, L11, L12, L13, L14, L15, L16, L17, L18, L19, L20, L21, L22, L23, L24, L25, L26, L27, L28, V1, V2, V3, V4, V5, V6, V7, V8, V9, V10, V11, V12, V13, V14)</p>	<p>----- ----- ----- -----</p>	
<p>Close CB-B Blocked <i>Indicates that the Close CB control is blocked by its interlocking logic.</i></p>	<p>Combination of (BO1, BO2, BO3, BO4, BO5, BO6, BO7, BO8, BO9, BO10, BO11, BO12, BO13, BO14, BO15, BO16, BO17, BO18, BO19, BO20, BO21, BO22, L1, L2, L3, L4, L5, L6, L7, L8, L9, L10, L11, L12, L13, L14, L15, L16, L17, L18, L19, L20, L21, L22, L23, L24, L25, L26, L27, L28, V1, V2, V3, V4, V5, V6, V7, V8, V9, V10, V11, V12, V13, V14)</p>	<p>----- ----- ----- -----</p>	

Description	Range	Default	Setting
<p>Open CB-B <i>Selects which inputs will issue an open to the circuit breaker.</i></p>	<p>Combination of (BO1, BO2, BO3, BO4, BO5, BO6, BO7, BO8, BO9, BO10, BO11, BO12, BO13, BO14, BO15, BO16, BO17, BO18, BO19, BO20, BO21, BO22, L1, L2, L3, L4, L5, L6, L7, L8, L9, L10, L11, L12, L13, L14, L15, L16, L17, L18, L19, L20, L21, L22, L23, L24, L25, L26, L27, L28, V1, V2, V3, V4, V5, V6, V7, V8, V9, V10, V11, V12, V13, V14)</p>	<p>----- ----- ----- -----</p>	
<p>CB-B Alarm <i>Indicates the CB is either in an illegal state or is stuck neither open or closed.</i></p>	<p>Combination of (BO1, BO2, BO3, BO4, BO5, BO6, BO7, BO8, BO9, BO10, BO11, BO12, BO13, BO14, BO15, BO16, BO17, BO18, BO19, BO20, BO21, BO22, L1, L2, L3, L4, L5, L6, L7, L8, L9, L10, L11, L12, L13, L14, L15, L16, L17, L18, L19, L20, L21, L22, L23, L24, L25, L26, L27, L28, V1, V2, V3, V4, V5, V6, V7, V8, V9, V10, V11, V12, V13, V14)</p>	<p>----- ----- ----- -----</p>	
<p>CB-B Closed <i>Selects which inputs are connected to the circuit breaker closed contacts</i></p>	<p>Combination of (BO1, BO2, BO3, BO4, BO5, BO6, BO7, BO8, BO9, BO10, BO11, BO12, BO13, BO14, BO15, BO16, BO17, BO18, BO19, BO20, BO21, BO22, L1, L2, L3, L4, L5, L6, L7, L8, L9, L10, L11, L12, L13, L14, L15, L16, L17, L18, L19, L20, L21, L22, L23, L24, L25, L26, L27, L28, V1, V2, V3, V4, V5, V6, V7, V8, V9, V10, V11, V12, V13, V14)</p>	<p>----- ----- ----- -----</p>	
<p>CB-B Open <i>Selects which inputs are connected to the circuit breaker open contacts</i></p>	<p>Combination of (BO1, BO2, BO3, BO4, BO5, BO6, BO7, BO8, BO9, BO10, BO11, BO12, BO13, BO14, BO15, BO16, BO17, BO18, BO19, BO20, BO21, BO22, L1, L2, L3, L4, L5, L6, L7, L8, L9, L10, L11, L12, L13, L14, L15, L16, L17, L18, L19, L20, L21, L22, L23, L24, L25, L26, L27, L28, V1, V2, V3, V4, V5, V6, V7, V8, V9, V10, V11, V12, V13, V14)</p>	<p>----- ----- ----- -----</p>	

Description	Range	Default	Setting
<p>Close CB-C Blocked</p> <p><i>Indicates that the Close CB control is blocked by its interlocking logic.</i></p>	<p>Combination of (BO1, BO2, BO3, BO4, BO5, BO6, BO7, BO8, BO9, BO10, BO11, BO12, BO13, BO14, BO15, BO16, BO17, BO18, BO19, BO20, BO21, BO22, L1, L2, L3, L4, L5, L6, L7, L8, L9, L10, L11, L12, L13, L14, L15, L16, L17, L18, L19, L20, L21, L22, L23, L24, L25, L26, L27, L28, V1, V2, V3, V4, V5, V6, V7, V8, V9, V10, V11, V12, V13, V14)</p>	<p>----- ----- ----- -----</p>	
<p>Open CB-C</p> <p><i>Selects which inputs will issue an open to the circuit breaker.</i></p>	<p>Combination of (BO1, BO2, BO3, BO4, BO5, BO6, BO7, BO8, BO9, BO10, BO11, BO12, BO13, BO14, BO15, BO16, BO17, BO18, BO19, BO20, BO21, BO22, L1, L2, L3, L4, L5, L6, L7, L8, L9, L10, L11, L12, L13, L14, L15, L16, L17, L18, L19, L20, L21, L22, L23, L24, L25, L26, L27, L28, V1, V2, V3, V4, V5, V6, V7, V8, V9, V10, V11, V12, V13, V14)</p>	<p>----- ----- ----- -----</p>	
<p>CB-C Alarm</p> <p><i>Indicates the CB is either in an illegal state or is stuck neither open or closed.</i></p>	<p>Combination of (BO1, BO2, BO3, BO4, BO5, BO6, BO7, BO8, BO9, BO10, BO11, BO12, BO13, BO14, BO15, BO16, BO17, BO18, BO19, BO20, BO21, BO22, L1, L2, L3, L4, L5, L6, L7, L8, L9, L10, L11, L12, L13, L14, L15, L16, L17, L18, L19, L20, L21, L22, L23, L24, L25, L26, L27, L28, V1, V2, V3, V4, V5, V6, V7, V8, V9, V10, V11, V12, V13, V14)</p>	<p>----- ----- ----- -----</p>	
<p>CB-C Closed</p> <p><i>Selects which inputs are connected to the circuit breaker closed contacts</i></p>	<p>Combination of (BO1, BO2, BO3, BO4, BO5, BO6, BO7, BO8, BO9, BO10, BO11, BO12, BO13, BO14, BO15, BO16, BO17, BO18, BO19, BO20, BO21, BO22, L1, L2, L3, L4, L5, L6, L7, L8, L9, L10, L11, L12, L13, L14, L15, L16, L17, L18, L19, L20, L21, L22, L23, L24, L25, L26, L27, L28, V1, V2, V3, V4, V5, V6, V7, V8, V9, V10, V11, V12, V13, V14)</p>	<p>----- ----- ----- -----</p>	

Description	Range	Default	Setting
<p>CB-C Open <i>Selects which inputs are connected to the circuit breaker open contacts</i></p>	<p>Combination of (BO1, BO2, BO3, BO4, BO5, BO6, BO7, BO8, BO9, BO10, BO11, BO12, BO13, BO14, BO15, BO16, BO17, BO18, BO19, BO20, BO21, BO22, L1, L2, L3, L4, L5, L6, L7, L8, L9, L10, L11, L12, L13, L14, L15, L16, L17, L18, L19, L20, L21, L22, L23, L24, L25, L26, L27, L28, V1, V2, V3, V4, V5, V6, V7, V8, V9, V10, V11, V12, V13, V14)</p>	<p>----- ----- ----- -----</p>	
<p>Pole Discrepancy <i>Indicates there is a CB pole discrepancy. i.e. 1 or 2 poles Open whilst 1 or 2 poles are closed. (This is not active in Mode C as single pole Lockout is allowed)</i></p>	<p>Combination of (BO1, BO2, BO3, BO4, BO5, BO6, BO7, BO8, BO9, BO10, BO11, BO12, BO13, BO14, BO15, BO16, BO17, BO18, BO19, BO20, BO21, BO22, L1, L2, L3, L4, L5, L6, L7, L8, L9, L10, L11, L12, L13, L14, L15, L16, L17, L18, L19, L20, L21, L22, L23, L24, L25, L26, L27, L28, V1, V2, V3, V4, V5, V6, V7, V8, V9, V10, V11, V12, V13, V14)</p>	<p>----- ----- ----- -----</p>	
<p>Manual Close CB-A <i>Close pulse due to Manual close being issued</i></p>	<p>Combination of (BO1, BO2, BO3, BO4, BO5, BO6, BO7, BO8, BO9, BO10, BO11, BO12, BO13, BO14, BO15, BO16, BO17, BO18, BO19, BO20, BO21, BO22, L1, L2, L3, L4, L5, L6, L7, L8, L9, L10, L11, L12, L13, L14, L15, L16, L17, L18, L19, L20, L21, L22, L23, L24, L25, L26, L27, L28, V1, V2, V3, V4, V5, V6, V7, V8, V9, V10, V11, V12, V13, V14)</p>	<p>----- ----- ----- -----</p>	
<p>79 AR Close CB-A <i>Close pulse due to auto-reclose sequence</i></p>	<p>Combination of (BO1, BO2, BO3, BO4, BO5, BO6, BO7, BO8, BO9, BO10, BO11, BO12, BO13, BO14, BO15, BO16, BO17, BO18, BO19, BO20, BO21, BO22, L1, L2, L3, L4, L5, L6, L7, L8, L9, L10, L11, L12, L13, L14, L15, L16, L17, L18, L19, L20, L21, L22, L23, L24, L25, L26, L27, L28, V1, V2, V3, V4, V5, V6, V7, V8, V9, V10, V11, V12, V13, V14)</p>	<p>----- ----- ----- -----</p>	

Description	Range	Default	Setting
Manual Close CB-B <i>Close pulse due to Manual close being issued</i>	Combination of (BO1, BO2, BO3, BO4, BO5, BO6, BO7, BO8, BO9, BO10, BO11, BO12, BO13, BO14, BO15, BO16, BO17, BO18, BO19, BO20, BO21, BO22, L1, L2, L3, L4, L5, L6, L7, L8, L9, L10, L11, L12, L13, L14, L15, L16, L17, L18, L19, L20, L21, L22, L23, L24, L25, L26, L27, L28, V1, V2, V3, V4, V5, V6, V7, V8, V9, V10, V11, V12, V13, V14)	----- ----- ----- -----	
79 AR Close CB-B <i>Close pulse due to auto-reclose sequence</i>	Combination of (BO1, BO2, BO3, BO4, BO5, BO6, BO7, BO8, BO9, BO10, BO11, BO12, BO13, BO14, BO15, BO16, BO17, BO18, BO19, BO20, BO21, BO22, L1, L2, L3, L4, L5, L6, L7, L8, L9, L10, L11, L12, L13, L14, L15, L16, L17, L18, L19, L20, L21, L22, L23, L24, L25, L26, L27, L28, V1, V2, V3, V4, V5, V6, V7, V8, V9, V10, V11, V12, V13, V14)	----- ----- ----- -----	
Manual Close CB-C <i>Close pulse due to Manual close being issued</i>	Combination of (BO1, BO2, BO3, BO4, BO5, BO6, BO7, BO8, BO9, BO10, BO11, BO12, BO13, BO14, BO15, BO16, BO17, BO18, BO19, BO20, BO21, BO22, L1, L2, L3, L4, L5, L6, L7, L8, L9, L10, L11, L12, L13, L14, L15, L16, L17, L18, L19, L20, L21, L22, L23, L24, L25, L26, L27, L28, V1, V2, V3, V4, V5, V6, V7, V8, V9, V10, V11, V12, V13, V14)	----- ----- ----- -----	
79 AR Close CB-C <i>Close pulse due to auto-reclose sequence</i>	Combination of (BO1, BO2, BO3, BO4, BO5, BO6, BO7, BO8, BO9, BO10, BO11, BO12, BO13, BO14, BO15, BO16, BO17, BO18, BO19, BO20, BO21, BO22, L1, L2, L3, L4, L5, L6, L7, L8, L9, L10, L11, L12, L13, L14, L15, L16, L17, L18, L19, L20, L21, L22, L23, L24, L25, L26, L27, L28, V1, V2, V3, V4, V5, V6, V7, V8, V9, V10, V11, V12, V13, V14)	----- ----- ----- -----	

Description	Range	Default	Setting
<p>79 Trip & Reclose <i>Indicates the Trip & Reclose sequence being performed</i></p>	<p>Combination of (BO1, BO2, BO3, BO4, BO5, BO6, BO7, BO8, BO9, BO10, BO11, BO12, BO13, BO14, BO15, BO16, BO17, BO18, BO19, BO20, BO21, BO22, L1, L2, L3, L4, L5, L6, L7, L8, L9, L10, L11, L12, L13, L14, L15, L16, L17, L18, L19, L20, L21, L22, L23, L24, L25, L26, L27, L28, V1, V2, V3, V4, V5, V6, V7, V8, V9, V10, V11, V12, V13, V14)</p>	<p>----- ----- ----- -----</p>	
<p>79 Trip & Lockout A <i>Selects which inputs will trigger a trip & lockout</i></p>	<p>Combination of (BO1, BO2, BO3, BO4, BO5, BO6, BO7, BO8, BO9, BO10, BO11, BO12, BO13, BO14, BO15, BO16, BO17, BO18, BO19, BO20, BO21, BO22, L1, L2, L3, L4, L5, L6, L7, L8, L9, L10, L11, L12, L13, L14, L15, L16, L17, L18, L19, L20, L21, L22, L23, L24, L25, L26, L27, L28, V1, V2, V3, V4, V5, V6, V7, V8, V9, V10, V11, V12, V13, V14)</p>	<p>----- ----- ----- -----</p>	
<p>79 Trip & Lockout B <i>As Above</i></p>	<p>Combination of (BO1, BO2, BO3, BO4, BO5, BO6, BO7, BO8, BO9, BO10, BO11, BO12, BO13, BO14, BO15, BO16, BO17, BO18, BO19, BO20, BO21, BO22, L1, L2, L3, L4, L5, L6, L7, L8, L9, L10, L11, L12, L13, L14, L15, L16, L17, L18, L19, L20, L21, L22, L23, L24, L25, L26, L27, L28, V1, V2, V3, V4, V5, V6, V7, V8, V9, V10, V11, V12, V13, V14)</p>	<p>----- ----- ----- -----</p>	
<p>79 Trip & Lockout C <i>As Above</i></p>	<p>Combination of (BO1, BO2, BO3, BO4, BO5, BO6, BO7, BO8, BO9, BO10, BO11, BO12, BO13, BO14, BO15, BO16, BO17, BO18, BO19, BO20, BO21, BO22, L1, L2, L3, L4, L5, L6, L7, L8, L9, L10, L11, L12, L13, L14, L15, L16, L17, L18, L19, L20, L21, L22, L23, L24, L25, L26, L27, L28, V1, V2, V3, V4, V5, V6, V7, V8, V9, V10, V11, V12, V13, V14)</p>	<p>----- ----- ----- -----</p>	

Description	Range	Default	Setting
<p>79 Lockout A</p> <p><i>Selects which inputs will force the Auto-recloser into the Lockout state</i></p>	<p>Combination of (BO1, BO2, BO3, BO4, BO5, BO6, BO7, BO8, BO9, BO10, BO11, BO12, BO13, BO14, BO15, BO16, BO17, BO18, BO19, BO20, BO21, BO22, L1, L2, L3, L4, L5, L6, L7, L8, L9, L10, L11, L12, L13, L14, L15, L16, L17, L18, L19, L20, L21, L22, L23, L24, L25, L26, L27, L28, V1, V2, V3, V4, V5, V6, V7, V8, V9, V10, V11, V12, V13, V14)</p>	<p>----- ----- ----- -----</p>	
<p>79 Lockout B</p> <p><i>As Above</i></p>	<p>Combination of (BO1, BO2, BO3, BO4, BO5, BO6, BO7, BO8, BO9, BO10, BO11, BO12, BO13, BO14, BO15, BO16, BO17, BO18, BO19, BO20, BO21, BO22, L1, L2, L3, L4, L5, L6, L7, L8, L9, L10, L11, L12, L13, L14, L15, L16, L17, L18, L19, L20, L21, L22, L23, L24, L25, L26, L27, L28, V1, V2, V3, V4, V5, V6, V7, V8, V9, V10, V11, V12, V13, V14)</p>	<p>----- ----- ----- -----</p>	
<p>79 Lockout C</p> <p><i>As Above</i></p>	<p>Combination of (BO1, BO2, BO3, BO4, BO5, BO6, BO7, BO8, BO9, BO10, BO11, BO12, BO13, BO14, BO15, BO16, BO17, BO18, BO19, BO20, BO21, BO22, L1, L2, L3, L4, L5, L6, L7, L8, L9, L10, L11, L12, L13, L14, L15, L16, L17, L18, L19, L20, L21, L22, L23, L24, L25, L26, L27, L28, V1, V2, V3, V4, V5, V6, V7, V8, V9, V10, V11, V12, V13, V14)</p>	<p>----- ----- ----- -----</p>	
<p>79 Out Of Service</p> <p><i>Indicates the auto-recloser is out of service</i></p>	<p>Combination of (BO1, BO2, BO3, BO4, BO5, BO6, BO7, BO8, BO9, BO10, BO11, BO12, BO13, BO14, BO15, BO16, BO17, BO18, BO19, BO20, BO21, BO22, L1, L2, L3, L4, L5, L6, L7, L8, L9, L10, L11, L12, L13, L14, L15, L16, L17, L18, L19, L20, L21, L22, L23, L24, L25, L26, L27, L28, V1, V2, V3, V4, V5, V6, V7, V8, V9, V10, V11, V12, V13, V14)</p>	<p>----- ----- ----- -----</p>	

Description	Range	Default	Setting
<p>79 In Service <i>Indicates the auto-recloser is in service</i></p>	<p>Combination of (BO1, BO2, BO3, BO4, BO5, BO6, BO7, BO8, BO9, BO10, BO11, BO12, BO13, BO14, BO15, BO16, BO17, BO18, BO19, BO20, BO21, BO22, L1, L2, L3, L4, L5, L6, L7, L8, L9, L10, L11, L12, L13, L14, L15, L16, L17, L18, L19, L20, L21, L22, L23, L24, L25, L26, L27, L28, V1, V2, V3, V4, V5, V6, V7, V8, V9, V10, V11, V12, V13, V14)</p>	<p>----- ----- ----- -----</p>	
<p>79 In Progress A <i>Indicates an auto-reclose sequence is in progress</i></p>	<p>Combination of (BO1, BO2, BO3, BO4, BO5, BO6, BO7, BO8, BO9, BO10, BO11, BO12, BO13, BO14, BO15, BO16, BO17, BO18, BO19, BO20, BO21, BO22, L1, L2, L3, L4, L5, L6, L7, L8, L9, L10, L11, L12, L13, L14, L15, L16, L17, L18, L19, L20, L21, L22, L23, L24, L25, L26, L27, L28, V1, V2, V3, V4, V5, V6, V7, V8, V9, V10, V11, V12, V13, V14)</p>	<p>----- ----- ----- -----</p>	
<p>79 In Progress B <i>As Above</i></p>	<p>Combination of (BO1, BO2, BO3, BO4, BO5, BO6, BO7, BO8, BO9, BO10, BO11, BO12, BO13, BO14, BO15, BO16, BO17, BO18, BO19, BO20, BO21, BO22, L1, L2, L3, L4, L5, L6, L7, L8, L9, L10, L11, L12, L13, L14, L15, L16, L17, L18, L19, L20, L21, L22, L23, L24, L25, L26, L27, L28, V1, V2, V3, V4, V5, V6, V7, V8, V9, V10, V11, V12, V13, V14)</p>	<p>----- ----- ----- -----</p>	
<p>79 In Progress C <i>As Above</i></p>	<p>Combination of (BO1, BO2, BO3, BO4, BO5, BO6, BO7, BO8, BO9, BO10, BO11, BO12, BO13, BO14, BO15, BO16, BO17, BO18, BO19, BO20, BO21, BO22, L1, L2, L3, L4, L5, L6, L7, L8, L9, L10, L11, L12, L13, L14, L15, L16, L17, L18, L19, L20, L21, L22, L23, L24, L25, L26, L27, L28, V1, V2, V3, V4, V5, V6, V7, V8, V9, V10, V11, V12, V13, V14)</p>	<p>----- ----- ----- -----</p>	

Description	Range	Default	Setting
<p>79 Block Extern <i>Indicates that Extern for the current shot has been selected to be delayed. (This may be used to block external tripping elements in the same way as the internal protection elements are blocked to achieve Instantaneous / Delayed operation.)</i></p>	<p>Combination of (BO1, BO2, BO3, BO4, BO5, BO6, BO7, BO8, BO9, BO10, BO11, BO12, BO13, BO14, BO15, BO16, BO17, BO18, BO19, BO20, BO21, BO22, L1, L2, L3, L4, L5, L6, L7, L8, L9, L10, L11, L12, L13, L14, L15, L16, L17, L18, L19, L20, L21, L22, L23, L24, L25, L26, L27, L28, V1, V2, V3, V4, V5, V6, V7, V8, V9, V10, V11, V12, V13, V14)</p>	<p>----- ----- ----- -----</p>	
<p>79 Fail To Close A <i>Indicates the CB was not closed at the end of the Close Pulse</i></p>	<p>Combination of (BO1, BO2, BO3, BO4, BO5, BO6, BO7, BO8, BO9, BO10, BO11, BO12, BO13, BO14, BO15, BO16, BO17, BO18, BO19, BO20, BO21, BO22, L1, L2, L3, L4, L5, L6, L7, L8, L9, L10, L11, L12, L13, L14, L15, L16, L17, L18, L19, L20, L21, L22, L23, L24, L25, L26, L27, L28, V1, V2, V3, V4, V5, V6, V7, V8, V9, V10, V11, V12, V13, V14)</p>	<p>----- ----- ----- -----</p>	
<p>79 Fail To Close B As Above</p>	<p>Combination of (BO1, BO2, BO3, BO4, BO5, BO6, BO7, BO8, BO9, BO10, BO11, BO12, BO13, BO14, BO15, BO16, BO17, BO18, BO19, BO20, BO21, BO22, L1, L2, L3, L4, L5, L6, L7, L8, L9, L10, L11, L12, L13, L14, L15, L16, L17, L18, L19, L20, L21, L22, L23, L24, L25, L26, L27, L28, V1, V2, V3, V4, V5, V6, V7, V8, V9, V10, V11, V12, V13, V14)</p>	<p>----- ----- ----- -----</p>	
<p>79 Fail To Close C As Above</p>	<p>Combination of (BO1, BO2, BO3, BO4, BO5, BO6, BO7, BO8, BO9, BO10, BO11, BO12, BO13, BO14, BO15, BO16, BO17, BO18, BO19, BO20, BO21, BO22, L1, L2, L3, L4, L5, L6, L7, L8, L9, L10, L11, L12, L13, L14, L15, L16, L17, L18, L19, L20, L21, L22, L23, L24, L25, L26, L27, L28, V1, V2, V3, V4, V5, V6, V7, V8, V9, V10, V11, V12, V13, V14)</p>	<p>----- ----- ----- -----</p>	

Description	Range	Default	Setting
<p>79 Close On Fault A <i>Indicates an element starter or trip operated during the Close Pulse</i></p>	<p>Combination of (BO1, BO2, BO3, BO4, BO5, BO6, BO7, BO8, BO9, BO10, BO11, BO12, BO13, BO14, BO15, BO16, BO17, BO18, BO19, BO20, BO21, BO22, L1, L2, L3, L4, L5, L6, L7, L8, L9, L10, L11, L12, L13, L14, L15, L16, L17, L18, L19, L20, L21, L22, L23, L24, L25, L26, L27, L28, V1, V2, V3, V4, V5, V6, V7, V8, V9, V10, V11, V12, V13, V14)</p>	<p>----- ----- ----- -----</p>	
<p>79 Close On Fault B <i>As Above</i></p>	<p>Combination of (BO1, BO2, BO3, BO4, BO5, BO6, BO7, BO8, BO9, BO10, BO11, BO12, BO13, BO14, BO15, BO16, BO17, BO18, BO19, BO20, BO21, BO22, L1, L2, L3, L4, L5, L6, L7, L8, L9, L10, L11, L12, L13, L14, L15, L16, L17, L18, L19, L20, L21, L22, L23, L24, L25, L26, L27, L28, V1, V2, V3, V4, V5, V6, V7, V8, V9, V10, V11, V12, V13, V14)</p>	<p>----- ----- ----- -----</p>	
<p>79 Close On Fault C <i>As Above</i></p>	<p>Combination of (BO1, BO2, BO3, BO4, BO5, BO6, BO7, BO8, BO9, BO10, BO11, BO12, BO13, BO14, BO15, BO16, BO17, BO18, BO19, BO20, BO21, BO22, L1, L2, L3, L4, L5, L6, L7, L8, L9, L10, L11, L12, L13, L14, L15, L16, L17, L18, L19, L20, L21, L22, L23, L24, L25, L26, L27, L28, V1, V2, V3, V4, V5, V6, V7, V8, V9, V10, V11, V12, V13, V14)</p>	<p>----- ----- ----- -----</p>	
<p>79 Successful AR A <i>Indicates that after a reclose and at the end of the Reclaim time the CB was closed and there were no auto-reclose trip elements operated. (This is issued for 2 secs)</i></p>	<p>Combination of (BO1, BO2, BO3, BO4, BO5, BO6, BO7, BO8, BO9, BO10, BO11, BO12, BO13, BO14, BO15, BO16, BO17, BO18, BO19, BO20, BO21, BO22, L1, L2, L3, L4, L5, L6, L7, L8, L9, L10, L11, L12, L13, L14, L15, L16, L17, L18, L19, L20, L21, L22, L23, L24, L25, L26, L27, L28, V1, V2, V3, V4, V5, V6, V7, V8, V9, V10, V11, V12, V13, V14)</p>	<p>----- ----- ----- -----</p>	

Description	Range	Default	Setting
79 Successful AR B As Above	Combination of (BO1, BO2, BO3, BO4, BO5, BO6, BO7, BO8, BO9, BO10, BO11, BO12, BO13, BO14, BO15, BO16, BO17, BO18, BO19, BO20, BO21, BO22, L1, L2, L3, L4, L5, L6, L7, L8, L9, L10, L11, L12, L13, L14, L15, L16, L17, L18, L19, L20, L21, L22, L23, L24, L25, L26, L27, L28, V1, V2, V3, V4, V5, V6, V7, V8, V9, V10, V11, V12, V13, V14)	----- ----- ----- -----	
79 Successful AR C As Above	Combination of (BO1, BO2, BO3, BO4, BO5, BO6, BO7, BO8, BO9, BO10, BO11, BO12, BO13, BO14, BO15, BO16, BO17, BO18, BO19, BO20, BO21, BO22, L1, L2, L3, L4, L5, L6, L7, L8, L9, L10, L11, L12, L13, L14, L15, L16, L17, L18, L19, L20, L21, L22, L23, L24, L25, L26, L27, L28, V1, V2, V3, V4, V5, V6, V7, V8, V9, V10, V11, V12, V13, V14)	----- ----- ----- -----	
Successful MC A <i>Indicates that after a manual close and at the end of the Reclaim time the CB was closed and there were no auto-reclose trip elements operated. (This is issued for 2 secs)</i>	Combination of (BO1, BO2, BO3, BO4, BO5, BO6, BO7, BO8, BO9, BO10, BO11, BO12, BO13, BO14, BO15, BO16, BO17, BO18, BO19, BO20, BO21, BO22, L1, L2, L3, L4, L5, L6, L7, L8, L9, L10, L11, L12, L13, L14, L15, L16, L17, L18, L19, L20, L21, L22, L23, L24, L25, L26, L27, L28, V1, V2, V3, V4, V5, V6, V7, V8, V9, V10, V11, V12, V13, V14)	----- ----- ----- -----	
Successful MC B As Above	Combination of (BO1, BO2, BO3, BO4, BO5, BO6, BO7, BO8, BO9, BO10, BO11, BO12, BO13, BO14, BO15, BO16, BO17, BO18, BO19, BO20, BO21, BO22, L1, L2, L3, L4, L5, L6, L7, L8, L9, L10, L11, L12, L13, L14, L15, L16, L17, L18, L19, L20, L21, L22, L23, L24, L25, L26, L27, L28, V1, V2, V3, V4, V5, V6, V7, V8, V9, V10, V11, V12, V13, V14)	----- ----- ----- -----	

Description	Range	Default	Setting
Successful MC C <i>As Above</i>	Combination of (BO1, BO2, BO3, BO4, BO5, BO6, BO7, BO8, BO9, BO10, BO11, BO12, BO13, BO14, BO15, BO16, BO17, BO18, BO19, BO20, BO21, BO22, L1, L2, L3, L4, L5, L6, L7, L8, L9, L10, L11, L12, L13, L14, L15, L16, L17, L18, L19, L20, L21, L22, L23, L24, L25, L26, L27, L28, V1, V2, V3, V4, V5, V6, V7, V8, V9, V10, V11, V12, V13, V14)	----- ----- ----- -----	
Hot Line Working <i>Indicates that Hot LineWorking functionality has been selected</i>	Combination of (BO1, BO2, BO3, BO4, BO5, BO6, BO7, BO8, BO9, BO10, BO11, BO12, BO13, BO14, BO15, BO16, BO17, BO18, BO19, BO20, BO21, BO22, L1, L2, L3, L4, L5, L6, L7, L8, L9, L10, L11, L12, L13, L14, L15, L16, L17, L18, L19, L20, L21, L22, L23, L24, L25, L26, L27, L28, V1, V2, V3, V4, V5, V6, V7, V8, V9, V10, V11, V12, V13, V14)	----- ----- ----- -----	
Inst Prot'n Out <i>Indicates that the protection elements selected to be Instantaneous elements are switched out</i>	Combination of (BO1, BO2, BO3, BO4, BO5, BO6, BO7, BO8, BO9, BO10, BO11, BO12, BO13, BO14, BO15, BO16, BO17, BO18, BO19, BO20, BO21, BO22, L1, L2, L3, L4, L5, L6, L7, L8, L9, L10, L11, L12, L13, L14, L15, L16, L17, L18, L19, L20, L21, L22, L23, L24, L25, L26, L27, L28, V1, V2, V3, V4, V5, V6, V7, V8, V9, V10, V11, V12, V13, V14)	----- ----- ----- -----	
E/F Out <i>Indicates that the instantaneous protection elements are switched out.</i>	Combination of (BO1, BO2, BO3, BO4, BO5, BO6, BO7, BO8, BO9, BO10, BO11, BO12, BO13, BO14, BO15, BO16, BO17, BO18, BO19, BO20, BO21, BO22, L1, L2, L3, L4, L5, L6, L7, L8, L9, L10, L11, L12, L13, L14, L15, L16, L17, L18, L19, L20, L21, L22, L23, L24, L25, L26, L27, L28, V1, V2, V3, V4, V5, V6, V7, V8, V9, V10, V11, V12, V13, V14)	----- ----- ----- -----	

Description	Range	Default	Setting
<p>SEF Out</p> <p><i>Indicates that the SEF protection elements are switched out</i></p>	<p>Combination of (BO1, BO2, BO3, BO4, BO5, BO6, BO7, BO8, BO9, BO10, BO11, BO12, BO13, BO14, BO15, BO16, BO17, BO18, BO19, BO20, BO21, BO22, L1, L2, L3, L4, L5, L6, L7, L8, L9, L10, L11, L12, L13, L14, L15, L16, L17, L18, L19, L20, L21, L22, L23, L24, L25, L26, L27, L28, V1, V2, V3, V4, V5, V6, V7, V8, V9, V10, V11, V12, V13, V14)</p>	<p>-----</p> <p>-----</p> <p>-----</p> <p>-----</p>	
<p>New Wave Stored</p> <p><i>The waveform recorder has stored new information Note: this is a pulsed output</i></p>	<p>Combination of (BO1, BO2, BO3, BO4, BO5, BO6, BO7, BO8, BO9, BO10, BO11, BO12, BO13, BO14, BO15, BO16, BO17, BO18, BO19, BO20, BO21, BO22, L1, L2, L3, L4, L5, L6, L7, L8, L9, L10, L11, L12, L13, L14, L15, L16, L17, L18, L19, L20, L21, L22, L23, L24, L25, L26, L27, L28, V1, V2, V3, V4, V5, V6, V7, V8, V9, V10, V11, V12, V13, V14)</p>	<p>-----</p> <p>-----</p> <p>-----</p> <p>-----</p>	
<p>New Fault Stored</p> <p><i>The fault recorder has stored new information Note: this is a pulsed output</i></p>	<p>Combination of (BO1, BO2, BO3, BO4, BO5, BO6, BO7, BO8, BO9, BO10, BO11, BO12, BO13, BO14, BO15, BO16, BO17, BO18, BO19, BO20, BO21, BO22, L1, L2, L3, L4, L5, L6, L7, L8, L9, L10, L11, L12, L13, L14, L15, L16, L17, L18, L19, L20, L21, L22, L23, L24, L25, L26, L27, L28, V1, V2, V3, V4, V5, V6, V7, V8, V9, V10, V11, V12, V13, V14)</p>	<p>-----</p> <p>-----</p> <p>-----</p> <p>-----</p>	
<p>Active Exp Pulse</p>	<p>Combination of (BO1, BO2, BO3, BO4, BO5, BO6, BO7, BO8, BO9, BO10, BO11, BO12, BO13, BO14, BO15, BO16, BO17, BO18, BO19, BO20, BO21, BO22, L1, L2, L3, L4, L5, L6, L7, L8, L9, L10, L11, L12, L13, L14, L15, L16, L17, L18, L19, L20, L21, L22, L23, L24, L25, L26, L27, L28, V1, V2, V3, V4, V5, V6, V7, V8, V9, V10, V11, V12, V13, V14)</p>	<p>-----</p> <p>-----</p> <p>-----</p> <p>-----</p>	

Description	Range	Default	Setting
Active Imp Pulse	Combination of (BO1, BO2, BO3, BO4, BO5, BO6, BO7, BO8, BO9, BO10, BO11, BO12, BO13, BO14, BO15, BO16, BO17, BO18, BO19, BO20, BO21, BO22, L1, L2, L3, L4, L5, L6, L7, L8, L9, L10, L11, L12, L13, L14, L15, L16, L17, L18, L19, L20, L21, L22, L23, L24, L25, L26, L27, L28, V1, V2, V3, V4, V5, V6, V7, V8, V9, V10, V11, V12, V13, V14)	----- ----- ----- -----	
Reactive Exp Pulse	Combination of (BO1, BO2, BO3, BO4, BO5, BO6, BO7, BO8, BO9, BO10, BO11, BO12, BO13, BO14, BO15, BO16, BO17, BO18, BO19, BO20, BO21, BO22, L1, L2, L3, L4, L5, L6, L7, L8, L9, L10, L11, L12, L13, L14, L15, L16, L17, L18, L19, L20, L21, L22, L23, L24, L25, L26, L27, L28, V1, V2, V3, V4, V5, V6, V7, V8, V9, V10, V11, V12, V13, V14)	----- ----- ----- -----	
Reactive Imp Pulse	Combination of (BO1, BO2, BO3, BO4, BO5, BO6, BO7, BO8, BO9, BO10, BO11, BO12, BO13, BO14, BO15, BO16, BO17, BO18, BO19, BO20, BO21, BO22, L1, L2, L3, L4, L5, L6, L7, L8, L9, L10, L11, L12, L13, L14, L15, L16, L17, L18, L19, L20, L21, L22, L23, L24, L25, L26, L27, L28, V1, V2, V3, V4, V5, V6, V7, V8, V9, V10, V11, V12, V13, V14)	----- ----- ----- -----	
Out Of Service Mode <i>Indicates the relay is in Out Of Service Mode</i>	Combination of (BO1, BO2, BO3, BO4, BO5, BO6, BO7, BO8, BO9, BO10, BO11, BO12, BO13, BO14, BO15, BO16, BO17, BO18, BO19, BO20, BO21, BO22, L1, L2, L3, L4, L5, L6, L7, L8, L9, L10, L11, L12, L13, L14, L15, L16, L17, L18, L19, L20, L21, L22, L23, L24, L25, L26, L27, L28, V1, V2, V3, V4, V5, V6, V7, V8, V9, V10, V11, V12, V13, V14)	----- ----- ----- -----	

Description	Range	Default	Setting
<p>Local Mode <i>Indicates the relay is in Local Mode</i></p>	<p>Combination of (BO1, BO2, BO3, BO4, BO5, BO6, BO7, BO8, BO9, BO10, BO11, BO12, BO13, BO14, BO15, BO16, BO17, BO18, BO19, BO20, BO21, BO22, L1, L2, L3, L4, L5, L6, L7, L8, L9, L10, L11, L12, L13, L14, L15, L16, L17, L18, L19, L20, L21, L22, L23, L24, L25, L26, L27, L28, V1, V2, V3, V4, V5, V6, V7, V8, V9, V10, V11, V12, V13, V14)</p>	<p>----- ----- ----- -----</p>	
<p>Remote Mode <i>Indicates the relay is in Remote Mode</i></p>	<p>Combination of (BO1, BO2, BO3, BO4, BO5, BO6, BO7, BO8, BO9, BO10, BO11, BO12, BO13, BO14, BO15, BO16, BO17, BO18, BO19, BO20, BO21, BO22, L1, L2, L3, L4, L5, L6, L7, L8, L9, L10, L11, L12, L13, L14, L15, L16, L17, L18, L19, L20, L21, L22, L23, L24, L25, L26, L27, L28, V1, V2, V3, V4, V5, V6, V7, V8, V9, V10, V11, V12, V13, V14)</p>	<p>----- ----- ----- -----</p>	
<p>BI 1 Operated <i>DC Binary Input 1 has operated</i></p>	<p>Combination of (BO1, BO2, BO3, BO4, BO5, BO6, BO7, BO8, BO9, BO10, BO11, BO12, BO13, BO14, BO15, BO16, BO17, BO18, BO19, BO20, BO21, BO22, L1, L2, L3, L4, L5, L6, L7, L8, L9, L10, L11, L12, L13, L14, L15, L16, L17, L18, L19, L20, L21, L22, L23, L24, L25, L26, L27, L28, V1, V2, V3, V4, V5, V6, V7, V8, V9, V10, V11, V12, V13, V14)</p>	<p>----- ----- ----- -----</p>	
<p>BI 2 Operated <i>DC Binary Input 2 has operated</i></p>	<p>Combination of (BO1, BO2, BO3, BO4, BO5, BO6, BO7, BO8, BO9, BO10, BO11, BO12, BO13, BO14, BO15, BO16, BO17, BO18, BO19, BO20, BO21, BO22, L1, L2, L3, L4, L5, L6, L7, L8, L9, L10, L11, L12, L13, L14, L15, L16, L17, L18, L19, L20, L21, L22, L23, L24, L25, L26, L27, L28, V1, V2, V3, V4, V5, V6, V7, V8, V9, V10, V11, V12, V13, V14)</p>	<p>----- ----- ----- -----</p>	

Description	Range	Default	Setting
BI 3 Operated <i>DC Binary Input 3 has operated</i>	Combination of (BO1, BO2, BO3, BO4, BO5, BO6, BO7, BO8, BO9, BO10, BO11, BO12, BO13, BO14, BO15, BO16, BO17, BO18, BO19, BO20, BO21, BO22, L1, L2, L3, L4, L5, L6, L7, L8, L9, L10, L11, L12, L13, L14, L15, L16, L17, L18, L19, L20, L21, L22, L23, L24, L25, L26, L27, L28, V1, V2, V3, V4, V5, V6, V7, V8, V9, V10, V11, V12, V13, V14)	----- ----- ----- -----	
BI 4 Operated <i>DC Binary Input 4 has operated</i>	Combination of (BO1, BO2, BO3, BO4, BO5, BO6, BO7, BO8, BO9, BO10, BO11, BO12, BO13, BO14, BO15, BO16, BO17, BO18, BO19, BO20, BO21, BO22, L1, L2, L3, L4, L5, L6, L7, L8, L9, L10, L11, L12, L13, L14, L15, L16, L17, L18, L19, L20, L21, L22, L23, L24, L25, L26, L27, L28, V1, V2, V3, V4, V5, V6, V7, V8, V9, V10, V11, V12, V13, V14)	----- ----- ----- -----	
BI 5 Operated <i>DC Binary Input 5 has operated</i>	Combination of (BO1, BO2, BO3, BO4, BO5, BO6, BO7, BO8, BO9, BO10, BO11, BO12, BO13, BO14, BO15, BO16, BO17, BO18, BO19, BO20, BO21, BO22, L1, L2, L3, L4, L5, L6, L7, L8, L9, L10, L11, L12, L13, L14, L15, L16, L17, L18, L19, L20, L21, L22, L23, L24, L25, L26, L27, L28, V1, V2, V3, V4, V5, V6, V7, V8, V9, V10, V11, V12, V13, V14)	----- ----- ----- -----	
BI 6 Operated <i>DC Binary Input 6 has operated</i>	Combination of (BO1, BO2, BO3, BO4, BO5, BO6, BO7, BO8, BO9, BO10, BO11, BO12, BO13, BO14, BO15, BO16, BO17, BO18, BO19, BO20, BO21, BO22, L1, L2, L3, L4, L5, L6, L7, L8, L9, L10, L11, L12, L13, L14, L15, L16, L17, L18, L19, L20, L21, L22, L23, L24, L25, L26, L27, L28, V1, V2, V3, V4, V5, V6, V7, V8, V9, V10, V11, V12, V13, V14)	----- ----- ----- -----	

Description	Range	Default	Setting
BI 7 Operated <i>DC Binary Input 7 has operated</i>	Combination of (BO1, BO2, BO3, BO4, BO5, BO6, BO7, BO8, BO9, BO10, BO11, BO12, BO13, BO14, BO15, BO16, BO17, BO18, BO19, BO20, BO21, BO22, L1, L2, L3, L4, L5, L6, L7, L8, L9, L10, L11, L12, L13, L14, L15, L16, L17, L18, L19, L20, L21, L22, L23, L24, L25, L26, L27, L28, V1, V2, V3, V4, V5, V6, V7, V8, V9, V10, V11, V12, V13, V14)	----- ----- ----- -----	
BI 8 Operated <i>DC Binary Input 8 has operated</i>	Combination of (BO1, BO2, BO3, BO4, BO5, BO6, BO7, BO8, BO9, BO10, BO11, BO12, BO13, BO14, BO15, BO16, BO17, BO18, BO19, BO20, BO21, BO22, L1, L2, L3, L4, L5, L6, L7, L8, L9, L10, L11, L12, L13, L14, L15, L16, L17, L18, L19, L20, L21, L22, L23, L24, L25, L26, L27, L28, V1, V2, V3, V4, V5, V6, V7, V8, V9, V10, V11, V12, V13, V14)	----- ----- ----- -----	
BI 9 Operated <i>DC Binary Input 9 has operated</i>	Combination of (BO1, BO2, BO3, BO4, BO5, BO6, BO7, BO8, BO9, BO10, BO11, BO12, BO13, BO14, BO15, BO16, BO17, BO18, BO19, BO20, BO21, BO22, L1, L2, L3, L4, L5, L6, L7, L8, L9, L10, L11, L12, L13, L14, L15, L16, L17, L18, L19, L20, L21, L22, L23, L24, L25, L26, L27, L28, V1, V2, V3, V4, V5, V6, V7, V8, V9, V10, V11, V12, V13, V14)	----- ----- ----- -----	
BI 10 Operated <i>DC Binary Input 10 has operated</i>	Combination of (BO1, BO2, BO3, BO4, BO5, BO6, BO7, BO8, BO9, BO10, BO11, BO12, BO13, BO14, BO15, BO16, BO17, BO18, BO19, BO20, BO21, BO22, L1, L2, L3, L4, L5, L6, L7, L8, L9, L10, L11, L12, L13, L14, L15, L16, L17, L18, L19, L20, L21, L22, L23, L24, L25, L26, L27, L28, V1, V2, V3, V4, V5, V6, V7, V8, V9, V10, V11, V12, V13, V14)	----- ----- ----- -----	

Description	Range	Default	Setting
BI 11 Operated <i>DC Binary Input 11 has operated</i>	Combination of (BO1, BO2, BO3, BO4, BO5, BO6, BO7, BO8, BO9, BO10, BO11, BO12, BO13, BO14, BO15, BO16, BO17, BO18, BO19, BO20, BO21, BO22, L1, L2, L3, L4, L5, L6, L7, L8, L9, L10, L11, L12, L13, L14, L15, L16, L17, L18, L19, L20, L21, L22, L23, L24, L25, L26, L27, L28, V1, V2, V3, V4, V5, V6, V7, V8, V9, V10, V11, V12, V13, V14)	----- ----- ----- -----	
BI 12 Operated <i>DC Binary Input 12 has operated</i>	Combination of (BO1, BO2, BO3, BO4, BO5, BO6, BO7, BO8, BO9, BO10, BO11, BO12, BO13, BO14, BO15, BO16, BO17, BO18, BO19, BO20, BO21, BO22, L1, L2, L3, L4, L5, L6, L7, L8, L9, L10, L11, L12, L13, L14, L15, L16, L17, L18, L19, L20, L21, L22, L23, L24, L25, L26, L27, L28, V1, V2, V3, V4, V5, V6, V7, V8, V9, V10, V11, V12, V13, V14)	----- ----- ----- -----	
BI 13 Operated <i>DC Binary Input 13 has operated</i>	Combination of (BO1, BO2, BO3, BO4, BO5, BO6, BO7, BO8, BO9, BO10, BO11, BO12, BO13, BO14, BO15, BO16, BO17, BO18, BO19, BO20, BO21, BO22, L1, L2, L3, L4, L5, L6, L7, L8, L9, L10, L11, L12, L13, L14, L15, L16, L17, L18, L19, L20, L21, L22, L23, L24, L25, L26, L27, L28, V1, V2, V3, V4, V5, V6, V7, V8, V9, V10, V11, V12, V13, V14)	----- ----- ----- -----	
BI 14 Operated <i>DC Binary Input 14 has operated</i>	Combination of (BO1, BO2, BO3, BO4, BO5, BO6, BO7, BO8, BO9, BO10, BO11, BO12, BO13, BO14, BO15, BO16, BO17, BO18, BO19, BO20, BO21, BO22, L1, L2, L3, L4, L5, L6, L7, L8, L9, L10, L11, L12, L13, L14, L15, L16, L17, L18, L19, L20, L21, L22, L23, L24, L25, L26, L27, L28, V1, V2, V3, V4, V5, V6, V7, V8, V9, V10, V11, V12, V13, V14)	----- ----- ----- -----	

Description	Range	Default	Setting
BI 15 Operated <i>DC Binary Input 15 has operated</i>	Combination of (BO1, BO2, BO3, BO4, BO5, BO6, BO7, BO8, BO9, BO10, BO11, BO12, BO13, BO14, BO15, BO16, BO17, BO18, BO19, BO20, BO21, BO22, L1, L2, L3, L4, L5, L6, L7, L8, L9, L10, L11, L12, L13, L14, L15, L16, L17, L18, L19, L20, L21, L22, L23, L24, L25, L26, L27, L28, V1, V2, V3, V4, V5, V6, V7, V8, V9, V10, V11, V12, V13, V14)	----- ----- ----- -----	
BI 16 Operated <i>DC Binary Input 16 has operated</i>	Combination of (BO1, BO2, BO3, BO4, BO5, BO6, BO7, BO8, BO9, BO10, BO11, BO12, BO13, BO14, BO15, BO16, BO17, BO18, BO19, BO20, BO21, BO22, L1, L2, L3, L4, L5, L6, L7, L8, L9, L10, L11, L12, L13, L14, L15, L16, L17, L18, L19, L20, L21, L22, L23, L24, L25, L26, L27, L28, V1, V2, V3, V4, V5, V6, V7, V8, V9, V10, V11, V12, V13, V14)	----- ----- ----- -----	
BI 17 Operated <i>DC Binary Input 17 has operated</i>	Combination of (BO1, BO2, BO3, BO4, BO5, BO6, BO7, BO8, BO9, BO10, BO11, BO12, BO13, BO14, BO15, BO16, BO17, BO18, BO19, BO20, BO21, BO22, L1, L2, L3, L4, L5, L6, L7, L8, L9, L10, L11, L12, L13, L14, L15, L16, L17, L18, L19, L20, L21, L22, L23, L24, L25, L26, L27, L28, V1, V2, V3, V4, V5, V6, V7, V8, V9, V10, V11, V12, V13, V14)	----- ----- ----- -----	
BI 18 Operated <i>DC Binary Input 18 has operated</i>	Combination of (BO1, BO2, BO3, BO4, BO5, BO6, BO7, BO8, BO9, BO10, BO11, BO12, BO13, BO14, BO15, BO16, BO17, BO18, BO19, BO20, BO21, BO22, L1, L2, L3, L4, L5, L6, L7, L8, L9, L10, L11, L12, L13, L14, L15, L16, L17, L18, L19, L20, L21, L22, L23, L24, L25, L26, L27, L28, V1, V2, V3, V4, V5, V6, V7, V8, V9, V10, V11, V12, V13, V14)	----- ----- ----- -----	

Description	Range	Default	Setting
BI 19 Operated <i>DC Binary Input 19 has operated</i>	Combination of (BO1, BO2, BO3, BO4, BO5, BO6, BO7, BO8, BO9, BO10, BO11, BO12, BO13, BO14, BO15, BO16, BO17, BO18, BO19, BO20, BO21, BO22, L1, L2, L3, L4, L5, L6, L7, L8, L9, L10, L11, L12, L13, L14, L15, L16, L17, L18, L19, L20, L21, L22, L23, L24, L25, L26, L27, L28, V1, V2, V3, V4, V5, V6, V7, V8, V9, V10, V11, V12, V13, V14)	----- ----- ----- -----	
BI 20 Operated <i>DC Binary Input 20 has operated</i>	Combination of (BO1, BO2, BO3, BO4, BO5, BO6, BO7, BO8, BO9, BO10, BO11, BO12, BO13, BO14, BO15, BO16, BO17, BO18, BO19, BO20, BO21, BO22, L1, L2, L3, L4, L5, L6, L7, L8, L9, L10, L11, L12, L13, L14, L15, L16, L17, L18, L19, L20, L21, L22, L23, L24, L25, L26, L27, L28, V1, V2, V3, V4, V5, V6, V7, V8, V9, V10, V11, V12, V13, V14)	----- ----- ----- -----	
BI 21 Operated <i>DC Binary Input 21 has operated</i>	Combination of (BO1, BO2, BO3, BO4, BO5, BO6, BO7, BO8, BO9, BO10, BO11, BO12, BO13, BO14, BO15, BO16, BO17, BO18, BO19, BO20, BO21, BO22, L1, L2, L3, L4, L5, L6, L7, L8, L9, L10, L11, L12, L13, L14, L15, L16, L17, L18, L19, L20, L21, L22, L23, L24, L25, L26, L27, L28, V1, V2, V3, V4, V5, V6, V7, V8, V9, V10, V11, V12, V13, V14)	----- ----- ----- -----	
BI 22 Operated <i>DC Binary Input 22 has operated</i>	Combination of (BO1, BO2, BO3, BO4, BO5, BO6, BO7, BO8, BO9, BO10, BO11, BO12, BO13, BO14, BO15, BO16, BO17, BO18, BO19, BO20, BO21, BO22, L1, L2, L3, L4, L5, L6, L7, L8, L9, L10, L11, L12, L13, L14, L15, L16, L17, L18, L19, L20, L21, L22, L23, L24, L25, L26, L27, L28, V1, V2, V3, V4, V5, V6, V7, V8, V9, V10, V11, V12, V13, V14)	----- ----- ----- -----	

Description	Range	Default	Setting
BI 23 Operated <i>DC Binary Input 23 has operated</i>	Combination of (BO1, BO2, BO3, BO4, BO5, BO6, BO7, BO8, BO9, BO10, BO11, BO12, BO13, BO14, BO15, BO16, BO17, BO18, BO19, BO20, BO21, BO22, L1, L2, L3, L4, L5, L6, L7, L8, L9, L10, L11, L12, L13, L14, L15, L16, L17, L18, L19, L20, L21, L22, L23, L24, L25, L26, L27, L28, V1, V2, V3, V4, V5, V6, V7, V8, V9, V10, V11, V12, V13, V14)	----- ----- ----- -----	
BI 24 Operated <i>DC Binary Input 24 has operated</i>	Combination of (BO1, BO2, BO3, BO4, BO5, BO6, BO7, BO8, BO9, BO10, BO11, BO12, BO13, BO14, BO15, BO16, BO17, BO18, BO19, BO20, BO21, BO22, L1, L2, L3, L4, L5, L6, L7, L8, L9, L10, L11, L12, L13, L14, L15, L16, L17, L18, L19, L20, L21, L22, L23, L24, L25, L26, L27, L28, V1, V2, V3, V4, V5, V6, V7, V8, V9, V10, V11, V12, V13, V14)	----- ----- ----- -----	
BI 25 Operated <i>DC Binary Input 25 has operated</i>	Combination of (BO1, BO2, BO3, BO4, BO5, BO6, BO7, BO8, BO9, BO10, BO11, BO12, BO13, BO14, BO15, BO16, BO17, BO18, BO19, BO20, BO21, BO22, L1, L2, L3, L4, L5, L6, L7, L8, L9, L10, L11, L12, L13, L14, L15, L16, L17, L18, L19, L20, L21, L22, L23, L24, L25, L26, L27, L28, V1, V2, V3, V4, V5, V6, V7, V8, V9, V10, V11, V12, V13, V14)	----- ----- ----- -----	
BI 26 Operated <i>DC Binary Input 26 has operated</i>	Combination of (BO1, BO2, BO3, BO4, BO5, BO6, BO7, BO8, BO9, BO10, BO11, BO12, BO13, BO14, BO15, BO16, BO17, BO18, BO19, BO20, BO21, BO22, L1, L2, L3, L4, L5, L6, L7, L8, L9, L10, L11, L12, L13, L14, L15, L16, L17, L18, L19, L20, L21, L22, L23, L24, L25, L26, L27, L28, V1, V2, V3, V4, V5, V6, V7, V8, V9, V10, V11, V12, V13, V14)	----- ----- ----- -----	

Description	Range	Default	Setting
BI 27 Operated <i>DC Binary Input 27 has operated</i>	Combination of (BO1, BO2, BO3, BO4, BO5, BO6, BO7, BO8, BO9, BO10, BO11, BO12, BO13, BO14, BO15, BO16, BO17, BO18, BO19, BO20, BO21, BO22, L1, L2, L3, L4, L5, L6, L7, L8, L9, L10, L11, L12, L13, L14, L15, L16, L17, L18, L19, L20, L21, L22, L23, L24, L25, L26, L27, L28, V1, V2, V3, V4, V5, V6, V7, V8, V9, V10, V11, V12, V13, V14)	----- ----- ----- -----	
BI 28 Operated <i>DC Binary Input 28 has operated</i>	Combination of (BO1, BO2, BO3, BO4, BO5, BO6, BO7, BO8, BO9, BO10, BO11, BO12, BO13, BO14, BO15, BO16, BO17, BO18, BO19, BO20, BO21, BO22, L1, L2, L3, L4, L5, L6, L7, L8, L9, L10, L11, L12, L13, L14, L15, L16, L17, L18, L19, L20, L21, L22, L23, L24, L25, L26, L27, L28, V1, V2, V3, V4, V5, V6, V7, V8, V9, V10, V11, V12, V13, V14)	----- ----- ----- -----	
BI 29 Operated <i>DC Binary Input 29 has operated</i>	Combination of (BO1, BO2, BO3, BO4, BO5, BO6, BO7, BO8, BO9, BO10, BO11, BO12, BO13, BO14, BO15, BO16, BO17, BO18, BO19, BO20, BO21, BO22, L1, L2, L3, L4, L5, L6, L7, L8, L9, L10, L11, L12, L13, L14, L15, L16, L17, L18, L19, L20, L21, L22, L23, L24, L25, L26, L27, L28, V1, V2, V3, V4, V5, V6, V7, V8, V9, V10, V11, V12, V13, V14)	----- ----- ----- -----	
BI 30 Operated <i>DC Binary Input 30 has operated</i>	Combination of (BO1, BO2, BO3, BO4, BO5, BO6, BO7, BO8, BO9, BO10, BO11, BO12, BO13, BO14, BO15, BO16, BO17, BO18, BO19, BO20, BO21, BO22, L1, L2, L3, L4, L5, L6, L7, L8, L9, L10, L11, L12, L13, L14, L15, L16, L17, L18, L19, L20, L21, L22, L23, L24, L25, L26, L27, L28, V1, V2, V3, V4, V5, V6, V7, V8, V9, V10, V11, V12, V13, V14)	----- ----- ----- -----	

Description	Range	Default	Setting
BI 31 Operated <i>DC Binary Input 31 has operated</i>	Combination of (BO1, BO2, BO3, BO4, BO5, BO6, BO7, BO8, BO9, BO10, BO11, BO12, BO13, BO14, BO15, BO16, BO17, BO18, BO19, BO20, BO21, BO22, L1, L2, L3, L4, L5, L6, L7, L8, L9, L10, L11, L12, L13, L14, L15, L16, L17, L18, L19, L20, L21, L22, L23, L24, L25, L26, L27, L28, V1, V2, V3, V4, V5, V6, V7, V8, V9, V10, V11, V12, V13, V14)	----- ----- ----- -----	
BI 32 Operated <i>DC Binary Input 32 has operated</i>	Combination of (BO1, BO2, BO3, BO4, BO5, BO6, BO7, BO8, BO9, BO10, BO11, BO12, BO13, BO14, BO15, BO16, BO17, BO18, BO19, BO20, BO21, BO22, L1, L2, L3, L4, L5, L6, L7, L8, L9, L10, L11, L12, L13, L14, L15, L16, L17, L18, L19, L20, L21, L22, L23, L24, L25, L26, L27, L28, V1, V2, V3, V4, V5, V6, V7, V8, V9, V10, V11, V12, V13, V14)	----- ----- ----- -----	
BI 33 Operated <i>DC Binary Input 33 has operated</i>	Combination of (BO1, BO2, BO3, BO4, BO5, BO6, BO7, BO8, BO9, BO10, BO11, BO12, BO13, BO14, BO15, BO16, BO17, BO18, BO19, BO20, BO21, BO22, L1, L2, L3, L4, L5, L6, L7, L8, L9, L10, L11, L12, L13, L14, L15, L16, L17, L18, L19, L20, L21, L22, L23, L24, L25, L26, L27, L28, V1, V2, V3, V4, V5, V6, V7, V8, V9, V10, V11, V12, V13, V14)	----- ----- ----- -----	
BI 34 Operated	Combination of (BO1, BO2, BO3, BO4, BO5, BO6, BO7, BO8, BO9, BO10, BO11, BO12, BO13, BO14, BO15, BO16, BO17, BO18, BO19, BO20, BO21, BO22, L1, L2, L3, L4, L5, L6, L7, L8, L9, L10, L11, L12, L13, L14, L15, L16, L17, L18, L19, L20, L21, L22, L23, L24, L25, L26, L27, L28, V1, V2, V3, V4, V5, V6, V7, V8, V9, V10, V11, V12, V13, V14)	----- ----- ----- -----	

Description	Range	Default	Setting
BI 35 Operated	Combination of (BO1, BO2, BO3, BO4, BO5, BO6, BO7, BO8, BO9, BO10, BO11, BO12, BO13, BO14, BO15, BO16, BO17, BO18, BO19, BO20, BO21, BO22, L1, L2, L3, L4, L5, L6, L7, L8, L9, L10, L11, L12, L13, L14, L15, L16, L17, L18, L19, L20, L21, L22, L23, L24, L25, L26, L27, L28, V1, V2, V3, V4, V5, V6, V7, V8, V9, V10, V11, V12, V13, V14)	----- ----- ----- -----	
BI 36 Operated	Combination of (BO1, BO2, BO3, BO4, BO5, BO6, BO7, BO8, BO9, BO10, BO11, BO12, BO13, BO14, BO15, BO16, BO17, BO18, BO19, BO20, BO21, BO22, L1, L2, L3, L4, L5, L6, L7, L8, L9, L10, L11, L12, L13, L14, L15, L16, L17, L18, L19, L20, L21, L22, L23, L24, L25, L26, L27, L28, V1, V2, V3, V4, V5, V6, V7, V8, V9, V10, V11, V12, V13, V14)	----- ----- ----- -----	
BI 37 Operated	Combination of (BO1, BO2, BO3, BO4, BO5, BO6, BO7, BO8, BO9, BO10, BO11, BO12, BO13, BO14, BO15, BO16, BO17, BO18, BO19, BO20, BO21, BO22, L1, L2, L3, L4, L5, L6, L7, L8, L9, L10, L11, L12, L13, L14, L15, L16, L17, L18, L19, L20, L21, L22, L23, L24, L25, L26, L27, L28, V1, V2, V3, V4, V5, V6, V7, V8, V9, V10, V11, V12, V13, V14)	----- ----- ----- -----	
BI 38 Operated	Combination of (BO1, BO2, BO3, BO4, BO5, BO6, BO7, BO8, BO9, BO10, BO11, BO12, BO13, BO14, BO15, BO16, BO17, BO18, BO19, BO20, BO21, BO22, L1, L2, L3, L4, L5, L6, L7, L8, L9, L10, L11, L12, L13, L14, L15, L16, L17, L18, L19, L20, L21, L22, L23, L24, L25, L26, L27, L28, V1, V2, V3, V4, V5, V6, V7, V8, V9, V10, V11, V12, V13, V14)	----- ----- ----- -----	

Description	Range	Default	Setting
BI 39 Operated	Combination of (BO1, BO2, BO3, BO4, BO5, BO6, BO7, BO8, BO9, BO10, BO11, BO12, BO13, BO14, BO15, BO16, BO17, BO18, BO19, BO20, BO21, BO22, L1, L2, L3, L4, L5, L6, L7, L8, L9, L10, L11, L12, L13, L14, L15, L16, L17, L18, L19, L20, L21, L22, L23, L24, L25, L26, L27, L28, V1, V2, V3, V4, V5, V6, V7, V8, V9, V10, V11, V12, V13, V14)	----- ----- ----- -----	
BI 40 Operated	Combination of (BO1, BO2, BO3, BO4, BO5, BO6, BO7, BO8, BO9, BO10, BO11, BO12, BO13, BO14, BO15, BO16, BO17, BO18, BO19, BO20, BO21, BO22, L1, L2, L3, L4, L5, L6, L7, L8, L9, L10, L11, L12, L13, L14, L15, L16, L17, L18, L19, L20, L21, L22, L23, L24, L25, L26, L27, L28, V1, V2, V3, V4, V5, V6, V7, V8, V9, V10, V11, V12, V13, V14)	----- ----- ----- -----	
BI 41 Operated	Combination of (BO1, BO2, BO3, BO4, BO5, BO6, BO7, BO8, BO9, BO10, BO11, BO12, BO13, BO14, BO15, BO16, BO17, BO18, BO19, BO20, BO21, BO22, L1, L2, L3, L4, L5, L6, L7, L8, L9, L10, L11, L12, L13, L14, L15, L16, L17, L18, L19, L20, L21, L22, L23, L24, L25, L26, L27, L28, V1, V2, V3, V4, V5, V6, V7, V8, V9, V10, V11, V12, V13, V14)	----- ----- ----- -----	
BI 42 Operated	Combination of (BO1, BO2, BO3, BO4, BO5, BO6, BO7, BO8, BO9, BO10, BO11, BO12, BO13, BO14, BO15, BO16, BO17, BO18, BO19, BO20, BO21, BO22, L1, L2, L3, L4, L5, L6, L7, L8, L9, L10, L11, L12, L13, L14, L15, L16, L17, L18, L19, L20, L21, L22, L23, L24, L25, L26, L27, L28, V1, V2, V3, V4, V5, V6, V7, V8, V9, V10, V11, V12, V13, V14)	----- ----- ----- -----	

Description	Range	Default	Setting
BI 43 Operated	Combination of (BO1, BO2, BO3, BO4, BO5, BO6, BO7, BO8, BO9, BO10, BO11, BO12, BO13, BO14, BO15, BO16, BO17, BO18, BO19, BO20, BO21, BO22, L1, L2, L3, L4, L5, L6, L7, L8, L9, L10, L11, L12, L13, L14, L15, L16, L17, L18, L19, L20, L21, L22, L23, L24, L25, L26, L27, L28, V1, V2, V3, V4, V5, V6, V7, V8, V9, V10, V11, V12, V13, V14)	----- ----- ----- -----	
E1 <i>Quick Logic equation 1 operated</i>	Combination of (BO1, BO2, BO3, BO4, BO5, BO6, BO7, BO8, BO9, BO10, BO11, BO12, BO13, BO14, BO15, BO16, BO17, BO18, BO19, BO20, BO21, BO22, L1, L2, L3, L4, L5, L6, L7, L8, L9, L10, L11, L12, L13, L14, L15, L16, L17, L18, L19, L20, L21, L22, L23, L24, L25, L26, L27, L28, V1, V2, V3, V4, V5, V6, V7, V8, V9, V10, V11, V12, V13, V14)	----- ----- ----- -----	
E2 <i>Quick Logic equation 2 operated</i>	Combination of (BO1, BO2, BO3, BO4, BO5, BO6, BO7, BO8, BO9, BO10, BO11, BO12, BO13, BO14, BO15, BO16, BO17, BO18, BO19, BO20, BO21, BO22, L1, L2, L3, L4, L5, L6, L7, L8, L9, L10, L11, L12, L13, L14, L15, L16, L17, L18, L19, L20, L21, L22, L23, L24, L25, L26, L27, L28, V1, V2, V3, V4, V5, V6, V7, V8, V9, V10, V11, V12, V13, V14)	----- ----- ----- -----	
E3 <i>Quick Logic equation 3 operated</i>	Combination of (BO1, BO2, BO3, BO4, BO5, BO6, BO7, BO8, BO9, BO10, BO11, BO12, BO13, BO14, BO15, BO16, BO17, BO18, BO19, BO20, BO21, BO22, L1, L2, L3, L4, L5, L6, L7, L8, L9, L10, L11, L12, L13, L14, L15, L16, L17, L18, L19, L20, L21, L22, L23, L24, L25, L26, L27, L28, V1, V2, V3, V4, V5, V6, V7, V8, V9, V10, V11, V12, V13, V14)	----- ----- ----- -----	

Description	Range	Default	Setting
E4 <i>Quick Logic equation 4 operated</i>	Combination of (BO1, BO2, BO3, BO4, BO5, BO6, BO7, BO8, BO9, BO10, BO11, BO12, BO13, BO14, BO15, BO16, BO17, BO18, BO19, BO20, BO21, BO22, L1, L2, L3, L4, L5, L6, L7, L8, L9, L10, L11, L12, L13, L14, L15, L16, L17, L18, L19, L20, L21, L22, L23, L24, L25, L26, L27, L28, V1, V2, V3, V4, V5, V6, V7, V8, V9, V10, V11, V12, V13, V14)	----- ----- ----- -----	
E5 <i>Quick Logic equation 5 operated</i>	Combination of (BO1, BO2, BO3, BO4, BO5, BO6, BO7, BO8, BO9, BO10, BO11, BO12, BO13, BO14, BO15, BO16, BO17, BO18, BO19, BO20, BO21, BO22, L1, L2, L3, L4, L5, L6, L7, L8, L9, L10, L11, L12, L13, L14, L15, L16, L17, L18, L19, L20, L21, L22, L23, L24, L25, L26, L27, L28, V1, V2, V3, V4, V5, V6, V7, V8, V9, V10, V11, V12, V13, V14)	----- ----- ----- -----	
E6 <i>Quick Logic equation 6 operated</i>	Combination of (BO1, BO2, BO3, BO4, BO5, BO6, BO7, BO8, BO9, BO10, BO11, BO12, BO13, BO14, BO15, BO16, BO17, BO18, BO19, BO20, BO21, BO22, L1, L2, L3, L4, L5, L6, L7, L8, L9, L10, L11, L12, L13, L14, L15, L16, L17, L18, L19, L20, L21, L22, L23, L24, L25, L26, L27, L28, V1, V2, V3, V4, V5, V6, V7, V8, V9, V10, V11, V12, V13, V14)	----- ----- ----- -----	
E7 <i>Quick Logic equation 7 operated</i>	Combination of (BO1, BO2, BO3, BO4, BO5, BO6, BO7, BO8, BO9, BO10, BO11, BO12, BO13, BO14, BO15, BO16, BO17, BO18, BO19, BO20, BO21, BO22, L1, L2, L3, L4, L5, L6, L7, L8, L9, L10, L11, L12, L13, L14, L15, L16, L17, L18, L19, L20, L21, L22, L23, L24, L25, L26, L27, L28, V1, V2, V3, V4, V5, V6, V7, V8, V9, V10, V11, V12, V13, V14)	----- ----- ----- -----	

Description	Range	Default	Setting
E8 <i>Quick Logic equation 8 operated</i>	Combination of (BO1, BO2, BO3, BO4, BO5, BO6, BO7, BO8, BO9, BO10, BO11, BO12, BO13, BO14, BO15, BO16, BO17, BO18, BO19, BO20, BO21, BO22, L1, L2, L3, L4, L5, L6, L7, L8, L9, L10, L11, L12, L13, L14, L15, L16, L17, L18, L19, L20, L21, L22, L23, L24, L25, L26, L27, L28, V1, V2, V3, V4, V5, V6, V7, V8, V9, V10, V11, V12, V13, V14)	----- ----- ----- -----	
E9 <i>Quick Logic equation 9 operated</i>	Combination of (BO1, BO2, BO3, BO4, BO5, BO6, BO7, BO8, BO9, BO10, BO11, BO12, BO13, BO14, BO15, BO16, BO17, BO18, BO19, BO20, BO21, BO22, L1, L2, L3, L4, L5, L6, L7, L8, L9, L10, L11, L12, L13, L14, L15, L16, L17, L18, L19, L20, L21, L22, L23, L24, L25, L26, L27, L28, V1, V2, V3, V4, V5, V6, V7, V8, V9, V10, V11, V12, V13, V14)	----- ----- ----- -----	
E10 <i>Quick Logic equation 10 operated</i>	Combination of (BO1, BO2, BO3, BO4, BO5, BO6, BO7, BO8, BO9, BO10, BO11, BO12, BO13, BO14, BO15, BO16, BO17, BO18, BO19, BO20, BO21, BO22, L1, L2, L3, L4, L5, L6, L7, L8, L9, L10, L11, L12, L13, L14, L15, L16, L17, L18, L19, L20, L21, L22, L23, L24, L25, L26, L27, L28, V1, V2, V3, V4, V5, V6, V7, V8, V9, V10, V11, V12, V13, V14)	----- ----- ----- -----	
E11 <i>Quick Logic equation 11 operated</i>	Combination of (BO1, BO2, BO3, BO4, BO5, BO6, BO7, BO8, BO9, BO10, BO11, BO12, BO13, BO14, BO15, BO16, BO17, BO18, BO19, BO20, BO21, BO22, L1, L2, L3, L4, L5, L6, L7, L8, L9, L10, L11, L12, L13, L14, L15, L16, L17, L18, L19, L20, L21, L22, L23, L24, L25, L26, L27, L28, V1, V2, V3, V4, V5, V6, V7, V8, V9, V10, V11, V12, V13, V14)	----- ----- ----- -----	

Description	Range	Default	Setting
E12 <i>Quick Logic equation 12 operated</i>	Combination of (BO1, BO2, BO3, BO4, BO5, BO6, BO7, BO8, BO9, BO10, BO11, BO12, BO13, BO14, BO15, BO16, BO17, BO18, BO19, BO20, BO21, BO22, L1, L2, L3, L4, L5, L6, L7, L8, L9, L10, L11, L12, L13, L14, L15, L16, L17, L18, L19, L20, L21, L22, L23, L24, L25, L26, L27, L28, V1, V2, V3, V4, V5, V6, V7, V8, V9, V10, V11, V12, V13, V14)	----- ----- ----- -----	
E13 <i>Quick Logic equation 13 operated</i>	Combination of (BO1, BO2, BO3, BO4, BO5, BO6, BO7, BO8, BO9, BO10, BO11, BO12, BO13, BO14, BO15, BO16, BO17, BO18, BO19, BO20, BO21, BO22, L1, L2, L3, L4, L5, L6, L7, L8, L9, L10, L11, L12, L13, L14, L15, L16, L17, L18, L19, L20, L21, L22, L23, L24, L25, L26, L27, L28, V1, V2, V3, V4, V5, V6, V7, V8, V9, V10, V11, V12, V13, V14)	----- ----- ----- -----	
E14 <i>Quick Logic equation 14 operated</i>	Combination of (BO1, BO2, BO3, BO4, BO5, BO6, BO7, BO8, BO9, BO10, BO11, BO12, BO13, BO14, BO15, BO16, BO17, BO18, BO19, BO20, BO21, BO22, L1, L2, L3, L4, L5, L6, L7, L8, L9, L10, L11, L12, L13, L14, L15, L16, L17, L18, L19, L20, L21, L22, L23, L24, L25, L26, L27, L28, V1, V2, V3, V4, V5, V6, V7, V8, V9, V10, V11, V12, V13, V14)	----- ----- ----- -----	
E15 <i>Quick Logic equation 15 operated</i>	Combination of (BO1, BO2, BO3, BO4, BO5, BO6, BO7, BO8, BO9, BO10, BO11, BO12, BO13, BO14, BO15, BO16, BO17, BO18, BO19, BO20, BO21, BO22, L1, L2, L3, L4, L5, L6, L7, L8, L9, L10, L11, L12, L13, L14, L15, L16, L17, L18, L19, L20, L21, L22, L23, L24, L25, L26, L27, L28, V1, V2, V3, V4, V5, V6, V7, V8, V9, V10, V11, V12, V13, V14)	----- ----- ----- -----	

Description	Range	Default	Setting
E16 <i>Quick Logic equation 16 operated</i>	Combination of (BO1, BO2, BO3, BO4, BO5, BO6, BO7, BO8, BO9, BO10, BO11, BO12, BO13, BO14, BO15, BO16, BO17, BO18, BO19, BO20, BO21, BO22, L1, L2, L3, L4, L5, L6, L7, L8, L9, L10, L11, L12, L13, L14, L15, L16, L17, L18, L19, L20, L21, L22, L23, L24, L25, L26, L27, L28, V1, V2, V3, V4, V5, V6, V7, V8, V9, V10, V11, V12, V13, V14)	----- ----- ----- -----	

5.9.2. Binary Output Config

Description	Range	Default	Setting
CB-A Trip Contacts <i>The Binary Outputs selected by this setting are classed as Trip contacts. (When any of these BOs operate the Trip LED is lit, CB Fail is started, if enabled, & a Fault Record is stored)</i>	Combination of (BO1, BO2, BO3, BO4, BO5, BO6, BO7, BO8, BO9, BO10, BO11, BO12, BO13, BO14, BO15, BO16, BO17, BO18, BO19, BO20, BO21, BO22)	----- ---	
CB-B Trip Contacts <i>As Above</i>	Combination of (BO1, BO2, BO3, BO4, BO5, BO6, BO7, BO8, BO9, BO10, BO11, BO12, BO13, BO14, BO15, BO16, BO17, BO18, BO19, BO20, BO21, BO22)	----- ---	
CB-C Trip Contacts <i>As Above</i>	Combination of (BO1, BO2, BO3, BO4, BO5, BO6, BO7, BO8, BO9, BO10, BO11, BO12, BO13, BO14, BO15, BO16, BO17, BO18, BO19, BO20, BO21, BO22)	----- ---	
Hand Reset Outputs <i>Relays selected, as Hand Reset will remain latched until manually reset from front panel or via communications link or by removing DC Supply. By default relays are Self Resetting and will reset when the driving signal is removed.</i>	Combination of (1, 2, 3, 4, 5, 6, 7, 8, 9, 10, 11, 12, 13, 14, 15, 16, 17, 18, 19, 20, 21, 22)	----- ---	
Min Operate Time 1 <i>Minimum operate time of output relay 1 if set to self reset, if also set to be pulsed then this is the pulse width</i>	0, 0.01 ... 59, 60	0.1s	
Min Operate Time 2 <i>Minimum operate time of output relay 2 if set to self reset, if also set to be pulsed then this is the pulse width</i>	0, 0.01 ... 59, 60	0.1s	
Min Operate Time 3 <i>Minimum operate time of output relay 3 if set to self reset, if also set to be pulsed then this is the pulse width</i>	0, 0.01 ... 59, 60	0.1s	
Min Operate Time 4 <i>Minimum operate time of output relay 4 if set to self reset, if also set to be pulsed then this is the pulse width</i>	0, 0.01 ... 59, 60	0.1s	

Description	Range	Default	Setting
Min Operate Time 5 <i>Minimum operate time of output relay 5 if set to self reset, if also set to be pulsed then this is the pulse width</i>	0, 0.01 ... 59, 60	0.1s	
Min Operate Time 6 <i>Minimum operate time of output relay 6 if set to self reset, if also set to be pulsed then this is the pulse width</i>	0, 0.01 ... 59, 60	0.1s	
Min Operate Time 7 <i>Minimum operate time of output relay 7 if set to self reset, if also set to be pulsed then this is the pulse width</i>	0, 0.01 ... 59, 60	0.1s	
Min Operate Time 8 <i>Minimum operate time of output relay 8 if set to self reset, if also set to be pulsed then this is the pulse width</i>	0, 0.01 ... 59, 60	0.1s	
Min Operate Time 9 <i>Minimum operate time of output relay 9 if set to self reset, if also set to be pulsed then this is the pulse width</i>	0, 0.01 ... 59, 60	0.1s	
Min Operate Time 10 <i>Minimum operate time of output relay 10 if set to self reset, if also set to be pulsed then this is the pulse width</i>	0, 0.01 ... 59, 60	0.1s	
Min Operate Time 11 <i>Minimum operate time of output relay 11 if set to self reset, if also set to be pulsed then this is the pulse width</i>	0, 0.01 ... 59, 60	0.1s	
Min Operate Time 12 <i>Minimum operate time of output relay 12 if set to self reset, if also set to be pulsed then this is the pulse width</i>	0, 0.01 ... 59, 60	0.1s	
Min Operate Time 13 <i>Minimum operate time of output relay 13 if set to self reset, if also set to be pulsed then this is the pulse width</i>	0, 0.01 ... 59, 60	0.1s	
Min Operate Time 14 <i>Minimum operate time of output relay 14 if set to self reset, if also set to be pulsed then this is the pulse width</i>	0, 0.01 ... 59, 60	0.1s	
Min Operate Time 15 <i>Minimum operate time of output relay 15 if set to self reset, if also set to be pulsed then this is the pulse width</i>	0, 0.01 ... 59, 60	0.1s	
Min Operate Time 16 <i>Minimum operate time of output relay 16 if set to self reset, if also set to be pulsed then this is the pulse width</i>	0, 0.01 ... 59, 60	0.1s	
Min Operate Time 17 <i>Minimum operate time of output relay 17 if set to self reset, if also set to be pulsed then this is the pulse width</i>	0, 0.01 ... 59, 60	0.1s	
Min Operate Time 18 <i>Minimum operate time of output relay 18 if set to self reset, if also set to be pulsed then this is the pulse width</i>	0, 0.01 ... 59, 60	0.1s	

Description	Range	Default	Setting
Min Operate Time 19 <i>Minimum operate time of output relay 19 if set to self reset, if also set to be pulsed then this is the pulse width</i>	0, 0.01 ... 59, 60	0.1s	
Min Operate Time 20 <i>Minimum operate time of output relay 20 if set to self reset, if also set to be pulsed then this is the pulse width</i>	0, 0.01 ... 59, 60	0.1s	
Min Operate Time 21 <i>Minimum operate time of output relay 21 if set to self reset, if also set to be pulsed then this is the pulse width</i>	0, 0.01 ... 59, 60	0.1s	
Min Operate Time 22 <i>Minimum operate time of output relay 22 if set to self reset, if also set to be pulsed then this is the pulse width</i>	0, 0.01 ... 59, 60	0.1s	
Pulsed Outputs <i>Selects which outputs are pulsed. The pulse width is set by the Min Operate Time setting for each output</i>	Combination of (1, 2, 3, 4, 5, 6, 7, 8, 9, 10, 11, 12, 13, 14, 15, 16, 17, 18, 19, 20, 21, 22)	----- ---	

5.9.3. LED Config

Description	Range	Default	Setting
Self Reset LEDs <i>LEDs selected, as Self Reset will automatically reset when the driving signal is removed. By default all LEDs are Hand Reset and must be manually reset either locally via the front fascia or remotely via communications.</i>	Combination of (1, 2, 3, 4, 5, 6, 7, 8, 9, 10, 11, 12, 13, 14, 15, 16, 17, 18, 19, 20, 21, 22, 23, 24, 25, 26, 27, 28)	17, 18, 19, 20, 21, 22, 23, 24, 25, 26, 27, 28	
Green LEDs <i>Selects which LEDs will be green when driven</i>	Combination of (1, 2, 3, 4, 5, 6, 7, 8, 9, 10, 11, 12, 13, 14, 15, 16, 17, 18, 19, 20, 21, 22, 23, 24, 25, 26, 27, 28)	----- -----	
Red LEDs <i>Selects which LEDs will be red when driven</i>	Combination of (1, 2, 3, 4, 5, 6, 7, 8, 9, 10, 11, 12, 13, 14, 15, 16, 17, 18, 19, 20, 21, 22, 23, 24, 25, 26, 27, 28)	1, 2, 3, 4, 5, 6, 7, 8, 9, 10, 11, 12, 13, 14, 15, 16, 17, 18, 19, 20, 21, 22, 23, 24, 25, 26, 27, 28	

5.9.4. Pickup Config

Description	Range	Default	Setting
Gn P/F Pickups <i>When any of the selected pickups operate General Pickup is driven.</i>	Combination of (51-1, 51-2, 51-3, 51-4, 50-1, 50-2, 50-3, 50-4)	51-1, 51-2, 51-3, 51-4, 50-1, 50-2, 50-3, 50-4	
Gn E/F Pickups <i>As Above</i>	Combination of (51G-1, 51G-2, 51G-3, 51G-4, 50G-1, 50G-2, 50G-3, 50G-4)	51G-1, 51G-2, 51G-3, 51G-4, 50G-1, 50G-2, 50G-3, 50G-4	

Description	Range	Default	Setting
Gn SEF/REF Pickups <i>As Above</i>	Combination of (51SEF-1, 51SEF-2, 51SEF-3, 51SEF-4, 50SEF-1, 50SEF-2, 50SEF-3, 50SEF-4, 64H)	51SEF-1, 51SEF-2, 51SEF-3, 51SEF-4, 50SEF-1, 50SEF-2, 50SEF-3, 50SEF-4, 64H	
Gn Voltage Pickups <i>As Above</i>	Combination of (27/59-1, 27/59-2, 27/59-3, 27/59-4, Vx 27/59, 47-1, 47-2, 59NIT, 59NDT)	27/59-1, 27/59-2, 27/59-3, 27/59-4, Vx 27/59, 47-1, 47-2, 59NIT, 59NDT	
Gn Freq Pickups <i>As Above</i>	Combination of (81-1, 81-2, 81-3, 81-4)	81-1, 81-2, 81-3, 81-4	
Gn Misc Pickups <i>As Above</i>	Combination of (46IT, 46DT, 37-1, 37-2)	46IT, 46DT, 37-1, 37-2	

5.10. Maintenance

5.10.1. CB Counters

Description	Range	Default	Setting
Gn CB-A Total TripCount <i>Selects whether the CB Total Trip Count counter is enabled</i>	Disabled, Enabled	Disabled	
Gn CB-A Total TripCount Target <i>Selects the number of CB trips allowed before CB Total Trip Count counter output operates</i>	0, 1 ... 9999, 10000	100	
Gn CB-A Total TripCount Reset <i>Resets CB Total Trip Count counter</i>			
Gn CB-B Total TripCount <i>Selects whether the CB Total Trip Count counter is enabled</i>	Disabled, Enabled	Disabled	
Gn CB-B Total TripCount Target <i>Selects the number of CB trips allowed before CB Total Trip Count counter output operates</i>	0, 1 ... 9999, 10000	100	
Gn CB-B Total TripCount Reset <i>Resets CB Total Trip Count counter</i>			
Gn CB-C Total TripCount <i>Selects whether the CB Total Trip Count counter is enabled</i>	Disabled, Enabled	Disabled	
Gn CB-C Total TripCount Target <i>Selects the number of CB trips allowed before CB Total Trip Count counter output operates</i>	0, 1 ... 9999, 10000	100	
Gn CB-C Total TripCount Reset <i>Resets CB Total Trip Count counter</i>			
Gn CB-A Delta TripCount <i>Selects whether the CB Delta Trip Count counter is enabled</i>	Disabled, Enabled	Disabled	

Description	Range	Default	Setting
Gn CB-A Delta TripCount Target <i>Selects the number of CB trips allowed before CB Delta Trip Count counter output operates</i>	0, 1 ... 9999, 10000	100	
Gn CB-A Delta TripCount Reset <i>Resets CB Delta Trip Count counter</i>			
Gn CB-B Delta TripCount <i>Selects whether the CB Delta Trip Count counter is enabled</i>	Disabled, Enabled	Disabled	
Gn CB-B Delta TripCount Target <i>Selects the number of CB trips allowed before CB Delta Trip Count counter output operates</i>	0, 1 ... 9999, 10000	100	
Gn CB-B Delta TripCount Reset <i>Resets CB Delta Trip Count counter</i>			
Gn CB-C Delta TripCount <i>Selects whether the CB Delta Trip Count counter is enabled</i>	Disabled, Enabled	Disabled	
Gn CB-C Delta TripCount Target <i>Selects the number of CB trips allowed before CB Delta Trip Count counter output operates</i>	0, 1 ... 9999, 10000	100	
Gn CB-C Delta TripCount Reset <i>Resets CB Delta Trip Count counter</i>			
Gn CB-A Count - ARBlock <i>Selects whether the CB Count To AR Block counter is enabled</i>	Disabled, Enabled	Disabled	
Gn CB-A Count - ARBlock Target <i>Selects the number of CB trips allowed before CB Count To AR Block counter output operates. While count is above target the Autorecloser will only perform 1 x Delayed Shot and Lockout</i>	0, 1 ... 9999, 10000	100	
Gn CB-A Count - ARBlock Reset <i>Resets CB Count To AR Block counter</i>			
Gn CB-B Count - ARBlock <i>Selects whether the CB Count To AR Block counter is enabled</i>	Disabled, Enabled	Disabled	
Gn CB-B Count - ARBlock Target <i>Selects the number of CB trips allowed before CB Count To AR Block counter output operates. While count is above target the Autorecloser will only perform 1 x Delayed Shot and Lockout</i>	0, 1 ... 9999, 10000	100	
Gn CB-B Count - ARBlock Reset <i>Resets CB Count To AR Block counter</i>			
Gn CB-C Count - ARBlock <i>Selects whether the CB Count To AR Block counter is enabled</i>	Disabled, Enabled	Disabled	
Gn CB-C Count - ARBlock Target <i>Selects the number of CB trips allowed before CB Count To AR Block counter output operates. While count is above target the Autorecloser will only perform 1 x Delayed Shot and Lockout</i>	0, 1 ... 9999, 10000	100	
Gn CB-C Count - ARBlock Reset <i>Resets CB Count To AR Block counter</i>			

Description	Range	Default	Setting
Gn CB-A Freq Ops Count <i>Selects whether the CB Frequent Operations Counter is enabled</i>	Disabled, Enabled	Disabled	
Gn CB-A Freq Ops Count Target <i>Selects the number of CB trips allowed before CB Frequent Operations Counter output operates. While count is above target the Autorecloser will only perform 1 x Delayed Shot and Lockout</i>	0, 1 ... 9999, 10000	100	
Gn CB-A Freq Ops Count Reset <i>Resets CB Frequent Operations Counter</i>			
Gn CB-B Freq Ops Count <i>Selects whether the CB Frequent Operations Counter is enabled</i>	Disabled, Enabled	Disabled	
Gn CB-B Freq Ops Count Target <i>Selects the number of CB trips allowed before CB Frequent Operations Counter output operates. While count is above target the Autorecloser will only perform 1 x Delayed Shot and Lockout</i>	0, 1 ... 9999, 10000	100	
Gn CB-B Freq Ops Count Reset <i>Resets CB Frequent Operations Counter</i>			
Gn CB-C Freq Ops Count <i>Selects whether the CB Frequent Operations Counter is enabled</i>	Disabled, Enabled	Disabled	
Gn CB-C Freq Ops Count Target <i>Selects the number of CB trips allowed before CB Frequent Operations Counter output operates. While count is above target the Autorecloser will only perform 1 x Delayed Shot and Lockout</i>	0, 1 ... 9999, 10000	100	
Gn CB-C Freq Ops Count Reset <i>Resets CB Frequent Operations Counter</i>			
Gn CB-A LO Handle Ops <i>Selects whether the CB Lockout operations Counter is enabled</i>	Disabled, Enabled	Disabled	
Gn CB-A LO Handle Ops Target <i>Selects the number of CB Lockout handle operations allowed before CB LO Handle Ops Count counter output operates</i>	0, 1 ... 9999, 10000	100	
Gn CB-A LO Handle Ops Reset <i>Resets CB Lockout Handle Operations Counter.</i>			
Gn CB-B LO Handle Ops <i>Selects whether the CB Lockout operations Counter is enabled</i>	Disabled, Enabled	Disabled	
Gn CB-B LO Handle Ops Target <i>Selects the number of CB Lockout handle operations allowed before CB LO Handle Ops Count counter output operates</i>	0, 1 ... 9999, 10000	100	
Gn CB-B LO Handle Ops Reset <i>Resets CB Lockout Handle Operations Counter.</i>			
Gn CB-C LO Handle Ops <i>Selects whether the CB Lockout operations Counter is enabled</i>	Disabled, Enabled	Disabled	

Description	Range	Default	Setting
Gn CB-C LO Handle Ops Target <i>Selects the number of CB Lockout handle operations allowed before CB LO Handle Ops Count counter output operates</i>	0, 1 ... 9999, 10000	100	
Gn CB-C LO Handle Ops Reset <i>Resets CB Lockout Handle Operations Counter.</i>			

5.10.2. I²T CB Wear

Description	Range	Default	Setting
Gn CB-A I ² t Counter <i>Selects whether the I²t CB Wear monitor is enabled</i>	Disabled, Enabled	Disabled	
Gn CB-A Alarm Limit <i>Sets limit before alarm is issued</i>	10, 11 ... 99000, 100000	10MA ² s	
Gn CB-A Separation Time <i>Sets the time for CB mechanism to start moving, time before contacts start to separate</i>	0, 0.001 ... 0.199, 0.2	0.02s	
Gn CB-A Clearance Time <i>Time for CB to clear fault</i>	0, 0.001 ... 0.199, 0.2	0.04s	
CB-A Reset I ² t Count <i>Reset the CB wear count</i>			
Gn CB-B I ² t Counter <i>Selects whether the I²t CB Wear monitor is enabled</i>	Disabled, Enabled	Disabled	
Gn CB-B Alarm Limit <i>Sets limit before alarm is issued</i>	10, 11 ... 99000, 100000	10MA ² s	
Gn CB-B Separation Time <i>Sets the time for CB mechanism to start moving, time before contacts start to separate</i>	0, 0.001 ... 0.199, 0.2	0.02s	
Gn CB-B Clearance Time <i>Time for CB to clear fault</i>	0, 0.001 ... 0.199, 0.2	0.04s	
CB-B Reset I ² t Count <i>Reset the CB wear count</i>			
Gn CB-C I ² t Counter <i>Selects whether the I²t CB Wear monitor is enabled</i>	Disabled, Enabled	Disabled	
Gn CB-C Alarm Limit <i>Sets limit before alarm is issued</i>	10, 11 ... 99000, 100000	10MA ² s	
Gn CB-C Separation Time <i>Sets the time for CB mechanism to start moving, time before contacts start to separate</i>	0, 0.001 ... 0.199, 0.2	0.02s	
Gn CB-C Clearance Time <i>Time for CB to clear fault</i>	0, 0.001 ... 0.199, 0.2	0.04s	
CB-C Reset I ² t Count <i>Reset the CB wear count</i>			

5.10.3. Output Matrix Test

5.11. Data Storage

5.11.1. Demand/Data Log

Description	Range	Default	Setting
Data Log Period <i>Selects period between stored samples</i>	5, 6, 7, 8, 9, 10, 15, 20, 25, 30, 35, 40, 45, 50, 55, 60	5min	
Clear Data Log <i>Clear the Data Log</i>			
Gn Demand Window <i>The time window over which the Min, Max and Mean values are calculated.</i>	1, 2 ... 23, 24	24hrs	
Gn Demand Window Type <i>Method used to calculate Demand values.</i>	Fixed, Peak, Rolling	Fixed	
Gn Demand Reset <i>Reset all Demand values</i>			

5.11.2. Waveform Storage

Description	Range	Default	Setting
Gn P/F Trig Storage <i>Select which elements trigger a waveform record</i>	Combination of (51-1, 51-2, 51-3, 51-4, 50-1, 50-2, 50-3, 50-4)	51-1, 51-2, 51-3, 51-4, 50-1, 50-2, 50-3, 50-4	
Gn E/F Trig Storage <i>As Above</i>	Combination of (51G-1, 51G-2, 51G-3, 51G-4, 50G-1, 50G-2, 50G-3, 50G-4)	51G-1, 51G-2, 51G-3, 51G-4, 50G-1, 50G-2, 50G-3, 50G-4	
Gn SEF/REF Trig Storage <i>As Above</i>	Combination of (51SEF-1, 51SEF-2, 51SEF-3, 51SEF-4, 50SEF-1, 50SEF-2, 50SEF-3, 50SEF-4, 64H)	51SEF-1, 51SEF-2, 51SEF-3, 51SEF-4, 50SEF-1, 50SEF-2, 50SEF-3, 50SEF-4, 64H	
Gn Misc Current Storage <i>As Above</i>	Combination of (46IT, 46DT, 37-1, 37-2, 49 Trip, 49 Alarm)	-----	
Gn Voltage Trig Storage <i>As Above</i>	Combination of (27/59-1, 27/59-2, 27/59-3, 27/59-4, Vx 27/59, 47-1, 47-2, 59NIT, 59NDT)	-----	
Gn Freq Trig Storage <i>As Above</i>	Combination of (81-1, 81-2, 81-3, 81-4)	----	
Pre-trigger Storage <i>Select Percentage of waveform record stored before the fault is triggered</i>	10, 20, 30, 40, 50, 60, 70, 80, 90	20%	
Record Duration <i>Select waveform record duration</i>	10 Rec x 1 Sec, 5 Rec x 2 Sec, 2 Rec x 5 Sec, 1 Rec x 10 Sec	10 Rec x 1 Sec	
Trigger Waveform <i>Trigger waveform storage</i>			
Clear Waveforms <i>Clear all stored waveform records</i>			

5.11.3. Fault Storage

Description	Range	Default	Setting
Gn Max Fault Rec Time <i>Maximum time Fault record information will be stored and classed as same fault</i>	0, 1 ... 59900, 60000	2000ms	
Clear Faults <i>Clear all stored fault records</i>			

5.11.4. Event Storage

Description	Range	Default	Setting
Clear Events <i>Clear all stored event records</i>			

5.11.5. Energy Storage

Description	Range	Default	Setting
Gn Active Exp Energy Unit	1kWh, 10kWh, 100kWh, 1MWh, 10MWh, 100MWh	10kWh	
Gn Active Imp Energy Unit	1kWh, 10kWh, 100kWh, 1MWh, 10MWh, 100MWh	10kWh	
Gn Reactive Exp Energy Unit	1kVArh, 10kVArh, 100kVArh, 1MVArh, 10MVArh, 100MVArh	10kVArh	
Gn Reactive Imp Energy Unit	1kVArh, 10kVArh, 100kVArh, 1MVArh, 10MVArh, 100MVArh	10kVArh	

5.12. Communications

Description	Range	Default	Setting
Station Address <i>IEC 60870-5-103 Station Address</i>	0, 1 ... 65533, 65534	0	
COM1-RS485 Protocol <i>Selects protocol to use for COM1-RS485</i>	OFF, IEC60870-5-103, MODBUS-RTU, DNP3, IEC60870-5-101	IEC60870-5-103	
COM1-RS485 Baud Rate <i>Sets the communications baud rate for COM1-RS485</i>	75, 110, 150, 300, 600, 1200, 2400, 4800, 9600, 19200, 38400	19200	
COM1-RS485 Parity <i>Selects whether parity information is used</i>	NONE, ODD, EVEN	EVEN	
COM1-RS485 Mode	Local, Remote, Local Or Remote	Remote	
COM3 Protocol <i>Selects protocol to use for COM3</i>	OFF, IEC60870-5-103, MODBUS-RTU, DNP3, IEC60870-5-101	IEC60870-5-103	
COM3 Baud Rate <i>Sets the communications baud rate for COM3</i>	75, 110, 150, 300, 600, 1200, 2400, 4800, 9600, 19200, 38400, 57600, 115200	19200	
COM3 Parity <i>Selects whether parity information is used</i>	NONE, ODD, EVEN	EVEN	
COM3 Line Idle <i>Selects the communications line idle sense</i>	LIGHT OFF, LIGHT ON	LIGHT OFF	
COM3 Data Echo <i>Enables echoing of data from RX port to TX port when operating relays in a Fibre Optic ring configuration</i>	OFF, ON	OFF	
COM3 Mode	Local, Remote, Local Or Remote	Remote	
COM4 Protocol <i>Selects protocol to use for COM4</i>	OFF, IEC60870-5-103, MODBUS-RTU, DNP3, IEC60870-5-101	OFF	
COM4 Baud Rate <i>Sets the communications baud rate for COM4</i>	75, 110, 150, 300, 600, 1200, 2400, 4800, 9600, 19200, 38400	19200	
COM4 Parity <i>Selects whether parity information is used</i>	NONE, ODD, EVEN	EVEN	
COM4 Line Idle <i>Selects the communications line idle sense</i>	LIGHT OFF, LIGHT ON	LIGHT OFF	
COM4 Data Echo <i>Enables echoing of data from RX port to TX port when operating relays in a Fibre Optic ring configuration</i>	OFF, ON	OFF	
COM4 Mode	Local, Remote, Local Or Remote	Remote	

Description	Range	Default	Setting
DNP3 Unsolicited Events <i>Allows unsolicited event support in the relay. When Enabled, unsolicited event transmission can be controlled by the Master. When Disabled, Master requests are ignored.</i>	Disabled, Enabled	Disabled	
DNP3 Destination Address <i>The address of the master to which unsolicited events will be sent.</i>	0, 1 ... 65533, 65534	0	
DNP3 Application Timeout	5, 6 ... 299, 300	10s	
I101 Link Mode	Balanced, Unbalanced	Unbalanced	
I101 Link Address	Not Present, 1 Octet , 2 Octets	1 Octet	
I101 Common Address of Asdu	1 Octet , 2 Octets	2 Octets	
I101 Cause of Trans. (COT)	1 Octet , 2 Octets	1 Octet	
I101 Info. Obj. Add. (IOA)	1 Octet , 2 Octets, 3 Octets	2 Octets	
I101 Asdu Address	0, 1 ... 65534, 65535	3	
I101 Cyclic Period	Off, 1 ... 3599, 3600	60s	
I101 Background Period	Off, 1 ... 1499, 1500	Off	

6. Relay Instrumentation

Instrument	Description
FAVOURITE METERS →to view	<p>This allows the user to view his previously constructed list of 'favourite meters' by pressing TEST/RESET ► button and the READ DOWN button to scroll though the meters added to this sub-group</p> <p>To construct a sub-group of favourite meters, first go to the desired meter then press ENTER this will cause a message to appear on the LCD 'Add To Favourites YES pressing ENTER again will add this to the FAVOURITE METERS Sub-menu. To remove a meter from the FAVOURITE METERS sub-menu go to that meter each in the FAVOURITE METERS sub-menu or at its Primary location press ENTER and the message 'Remove From Favourites' will appear press ENTER again and this meter will be removed from the FAVOURITE METERS sub-group</p>

CURRENT METERS →to view	<p>This is the sub-group that includes all the meters that are associated with Current TEST/RESET ► allows access to this sub-group</p>
Primary Current Ia 0.00A Ib 0.00A Ic 0.00A	Displays the 3 phase currents Primary RMS values
Secondary Current Ia 0.00A Ib 0.00A Ic 0.00A	Displays the 3 phase currents Secondary RMS values
Nom Current Ia 0.00xIn ----° Ib 0.00xIn ----° Ic 0.00xIn ----°	Displays the 3 Phase currents Nominal RMS values & phase angles with respect to PPS voltage.
Pri Earth Current In 0.000A I _g 0.000A I _{sef} 0.000A	Displays the 3 Earth currents Primary RMS values
Sec Earth Current In 0.000A I _g 0.000A I _{sef} 0.000A	Displays the 3 Earth currents Secondary RMS values
Nom Earth Current In 0.000xIn----° I _g 0.000xIn----° I _{sef} 0.000xIn----°	Displays the 3 Earth currents Nominal RMS values & phase angles with respect to PPS voltage.
I Seq Components I _{zps} 0.00xIn----° I _{pps} 0.00xIn----° I _{nps} 0.00xIn----°	Displays the Current Sequence components Nominal RMS values & phase angles with respect to PPS voltage.
2 nd Harmonic Current Ia 0.00xIn Ib 0.00xIn Ic 0.00xIn	Displays the 3 phase currents' 2 nd Harmonic components Nominal RMS values.

VOLTAGE METERS		This is the sub-group that includes all the meters that are associated with Voltage TEST/RESET ► allows access to this sub-group
→to view		
Prim Ph-Ph Voltage		Displays the Phase to Phase Voltage Primary RMS values
Vab	0.00V	
Vbc	0.00V	
Vca	0.00V	
Sec Ph-Ph Voltage		Displays the Phase to Phase Voltage Secondary RMS
Vab	0.00V	
Vbc	0.00V	
Vca	0.00V	
Nominal Ph-Ph Voltage		Displays the Phase to Phase Voltage Nominal RMS values & Angles with respect to PPS voltage.
Vab	0.00V ----°	
Vbc	0.00V ----°	
Vca	0.00V ----°	
Prim Ph-N Voltage		Displays the Phase to Neutral Voltage Primary RMS values
Va	0.00V	
Vb	0.00V	
Vc	0.00V	
Sec Ph-N Voltage		Displays the Phase to Neutral Voltage Secondary RMS values
Va	0.00V	
Vb	0.00V	
Vc	0.00V	
Nom Ph-N Voltage		Displays the Phase to Neutral Voltage Nominal RMS values & Angles with respect to PPS voltage.
Va	0.00V ----°	
Vb	0.00V ----°	
Vc	0.00V ----°	
V Seq Components		Displays the Voltage Sequence components Nominal RMS values & phase angles with respect to PPS voltage.
Izps	0.00V ----°	
Ipps	0.00V ----°	
Inps	0.00V ----°	
Calc Earth Voltage		Displays the calculated Earth voltage both primary and secondary which also shows the secondary angle
Pri	0.00V	
Sec	0.00V ----°	
CS/NVD Voltage (Vx)		Displays the 4 th voltage (Vx) both primary and secondary which also shows the secondary angle. This voltage can be used for NVD, Vx 27/59 or where available Checksync.
Pri	0.00V	
Sec	0.00V ----°	

FREQUENCY METERS		This is the sub-group that includes all the meters that are associated with Frequency TEST/RESET ► allows access to this sub-group
→to view		
Frequency	00.000Hz	Displays the power system frequency.

POWER METERS		This is the sub-group that includes all the meters that are associated with Power TEST/RESET ► allows access to this sub-group
→to view		
Phase A	0.0W	Displays Real Power
Phase B	0.0W	
Phase C	0.0W	
P (3P)	0.0W	
Phase A	0.0VAr	Displays Reactive Power
Phase B	0.0VAr	
Phase C	0.0VAr	
Q (3P)	0.0VAr	
Phase A	0.0VA	Displays Apparent Power
Phase B	0.0VA	

Phase C	0.0VA	
S (3P)	0.0VA	
PF A	0.00	Displays Power factor
PF B	0.00	
PF C	0.00	
PF (3P)	0.00	

ENERGY METERS		This is the sub-group that includes all the meters that are associated with Energy TEST/RESET ► allows access to this sub-group
→to view		
Active Energy		Displays both imported and exported Active Energy
Exp	0.00MWh	
Imp	0.00MWh	
Reactive Energy		Displays both imported and exported Reactive Energy
Exp	0.00MVAh	
Imp	0.00MVAh	

DIRECTIONAL METERS		This is the sub-group that includes all the meters that are associated with Directional elements TEST/RESET ► allows access to this sub-group. Only seen on models that have the 67 option
→to view		
P/F Dir (67)		The appropriate values from the selection will be displayed.
----- No Dir, PhA Fwd, PhA Rev, PhB Fwd, PhB Rev, PhC Fwd, PhC Rev		
Meas E/F Dir (67G)		The appropriate values from the selection will be displayed.
----- No Dir, E/F Fwd, E/F Rev		
SEF Dir (67SEF)		The appropriate values from the selection will be displayed.
----- No Dir, SEF Fwd, SEF Rev		

THERMAL METERS		This is the sub-group that includes all the meters that are associated with Thermal TEST/RESET ► allows access to this sub-group
→to view		
Thermal Status		Displays the thermal capacity
Phase A	0.0%	
Phase B	0.0%	
Phase C	0.0%	

AUTORECLOSE METERS		This is the sub-group that includes all the meters that are associated with Autoreclose TEST/RESET ► allows access to this sub-group. Only seen on models that have the 79 option
→to view		
79 AR State		
AR Close Shot	0	

SYNC METERS		This is the sub-group that includes all the meters that are associated with Synchronising TEST/RESET ► allows access to this sub-group
→to view		
Line Volts	0.00V	Displays the voltages used for synchronising
Bus Volts	0.00V	
Line Freq	0.000Hz	
Bus Freq	0.000Hz	
Phase Diff	0.0Deg	Displays the calculated synchronising parameters
Slip Freq	0.000Hz	
Voltage Diff	0%	

MAINTENANCE METERS →to view	This is the sub-group that includes all the meters that are associated with Maintenance TEST/RESET ► allows access to this sub-group
CB Total Trips Count 0 Target 100	Displays the number of CB trips experienced by the CB
CB Delta Trips Count 0 Target 100	Displays the number of CB trips experienced by the CB
CB Count To AR Block Count 0 Target 100	Displays the number of CB trips experienced by the CB. When the target is reached the relay will only do 1 Delayed Trip to Lockout.
CB Freq Ops Count Count 0 Target 10	Displays the number of CB trips experienced by the CB over the last rolling 1 hr period. When the target is reached the relay will only do 1 Delayed Trip to Lockout.
CB LO Handle Ops Count 0 Target 10	Displays the number of CB Lockout Handle operations since last reset.
CB Wear Phase A 0.00MA ² s Phase B 0.00MA ² s Phase C 0.00MA ² s	Displays the current measure of circuit breaker wear.

GENERAL ALARM METERS →to view	This is the sub-group that includes all the meters that are associated with the Binary inputs TEST/RESET ► allows access to this sub-group
General Alarms ALARM 1 Cleared	Displays the state of General Alarm
General Alarms ALARM 2 Cleared	
General Alarms ALARM 3 Cleared	
General Alarms ALARM 4 Cleared	
General Alarms ALARM 5 Cleared	
General Alarms ALARM 6 Cleared	
General Alarms ALARM 7 Cleared	
General Alarms ALARM 8 Cleared	
General Alarms ALARM 9 Cleared	
General Alarms ALARM 10 Cleared	
General Alarms ALARM 11 Cleared	

Cleared	
General Alarms ALARM 12 Cleared	

BATTERY CONDITION →to view	This is the sub-group that includes all the meters that are associated with the Battery Condition. TEST/RESET ► allows access to this sub-group
Battery Volts High Resistance Ohms Aux dc Volts	Displays the state of the Battery Voltage, Resistance and Auxiliary voltage.

CAPACITOR CONDITION →to view	This is the sub-group that includes all the meters that are associated with the Capacitor Condition TEST/RESET ► allows access to this sub-group
Supply Fail	Displays the state of the capacitor.

POWER QUALITY METERS →to view	This is the sub-group that includes all the meters that are associated with the Power Quality TEST/RESET ► allows access to this sub-group
Pole1 27Sag SARFI SIARFI 0 SMARFI 0 STARFI 0	Displays the state of the Pole 1 27 Sag.
Pole2 27Sag SARFI SIARFI 0 SMARFI 0 STARFI 0	Displays the state of the Pole 2 27 Sag.
Pole3 27Sag SARFI SIARFI 0 SMARFI 0 STARFI 0	Displays the state of the Pole 3 27 Sag.
System Interruptions P1 Interrupts 0 P2 Interrupts 0 P3 Interrupts 0	Displays the number of System Interruptions.
Pole1 59Swell SARFI SIARFI 0 SMARFI 0 STARFI 0	Displays the state of the Pole 1 59 Swell.
Pole2 59Swell SARFI SIARFI 0 SMARFI 0 STARFI 0	Displays the state of the Pole 2 59 Swell.
Pole3 59Swell SARFI SIARFI 0 SMARFI 0 STARFI 0	Displays the state of the Pole 3 59 Swell.

DEMAND METERS →to view	This is the sub-group that includes all the meters that are associated with the Demand TEST/RESET ► allows access to this sub-group
V Phase A Demand Max 0.00V Min 0.00V	Displays the demand values for voltage phase A.

Mean 0.00V		
V Phase B Demand Max Min Mean	0.00V 0.00V 0.00V	Displays the demand values for voltage phase B.
V Phase C Demand Max Min Mean	0.00V 0.00V 0.00V	Displays the demand values for voltage phase C.
V Phase AB Demand Max Min Mean	0.00V 0.00V 0.00V	Displays the demand values for voltage phase-phase AB.
V Phase BC Demand Max Min Mean	0.00V 0.00V 0.00V	Displays the demand values for voltage phase-phase BC.
V Phase CA Demand Max Min Mean	0.00V 0.00V 0.00V	Displays the demand values for voltage phase-phase CA.
I Phase A Demand Max Min Mean	0.00A 0.00A 0.00A	Displays the demand values for current phase A.
I Phase B Demand Max Min Mean	0.00A 0.00A 0.00A	Displays the demand values for current phase B.
I Phase C Demand Max Min Mean	0.00A 0.00A 0.00A	Displays the demand values for current phase C.
Power P 3P Demand Max Min Mean	0.0W 0.0W 0.0W	Displays the demand values for Power P 3P.
Power Q 3P Demand Max Min Mean	0.0VAr 0.0VAr 0.0VAr	Displays the demand values for Power Q 3P.
Power S 3P Demand Max Min	0.0WA 0.0WA	Displays the demand values for Power S 3P.

Mean	0.0WA	
Frequency Demand		Displays the demand values for Frequency.
Max	0.000Hz	
Min	0.000Hz	
Mean	0.000Hz	

FAULT LOCATOR		This is the sub-group that includes all the meters that are associated with the Fault Locator TEST/RESET ► allows access to this sub-group
→to view		
Distance	0.0%	Displays the Fault Location.
Impedance	0.0ohms	
Reactance	0.0ohms	

BINARY INPUT METERS		This is the sub-group that includes all the meters that are associated with the Binary inputs TEST/RESET ► allows access to this sub-group
→to view		
BI 1-8	---- ----	Displays the state of DC binary inputs 1 to 8 (The number of binary inputs may vary depending on model)
BI 9-13	---- -	

BINARY OUTPUT METERS		This is the sub-group that includes all the meters that are associated with the Binary Outputs TEST/RESET ► allows access to this sub-group
→to view		
BO 1-8	---- ----	Displays the state of DC binary Outputs 1 to 8. (The number of binary outputs may vary depending on model)
BO 9-14	---- --	

VIRTUAL METERS		This is the sub-group that shows the state of the virtual status inputs in the relay TEST/RESET ► allows access to this sub-group
→to view		
V 1-8	---- ----	Displays the state of Virtual Outputs 1 to 16 (The number of virtual inputs will vary depending on model)
V 9-16	---- ----	

COMMUNICATION METERS		This is the sub-group that includes all the meters that are associated with Communications ports TEST/RESET ► allows access to this sub-group
→to view		
COM1		Displays which com ports are currently active
COM2		
COM3		
COM4		
COM1 TRAFFIC		Displays traffic on Com1
Tx1	0	
Rx1	0	
Rx1 Errors	0	
COM2 TRAFFIC		Displays traffic on Com2
Tx2	0	
Rx2	0	
Rx2 Errors	0	
COM3 TRAFFIC		Displays traffic on Com3
Tx3	0	
Rx3	0	
Rx3 Errors	0	
COM4 TRAFFIC		Displays traffic on Com4
Tx4	0	
Rx4	0	
Rx4 Errors	0	

MISCELLANEOUS METERS		This is the sub-group that includes indication such as the relays time and date, the amount of fault and waveform records stored in the relay TEST/RESET ► allows access to this sub-group
→to view		
Date	01/01/2000	This meter displays the date and time and the number of Fault records and Event records stored in the relay
Time	22:41:44	
Waveform Recs	0	
Fault Recs	0	
Event Recs	0	
Data Log Recs	0	